



TOWN OF QUISPAMSIS

GENERAL SPECIFICATIONS

FOR

MUNICIPAL SERVICES

ISSUED: APRIL 2026

REVISION NO. 03

## APRIL 2026 UPDATES TO THE MUNICIPAL SPECIFICATIONS

- .1 Table of Contents has been updated to include the new Section 32 17 23 – Pavement Markings and Section 32 92 24 – Topsoil, Hydraulic Seeding and Sodding.
- .2 Division 00 – Procurement and Contracting Requirements has been updated as follows:
  - .1 Section 00 21 13 – Instructions to Tenderers has been updated as follows:
    - .1 On page 4: 1.13.3 “Complete the Tender Form in ink or typewritten and have corrections initialled by the individual signing the tender.”
- .3 Division 01 - General Requirements has been updated as follows:
  - .1 Section 01 35 43 - Project Specific Environmental Procedures has been updated as follows:
    - .1 On page 4: 1.11.3 “Dust control shall be paid by the number of 20 kg bags of Calcium Chloride...accepted work.”
- .4 Division 31 – Earthworks has been updated as follows:
  - .1 Section 31 23 33.01 - Excavating, Trenching, Bedding and Backfilling has been updated as follows:
    - .1 On page 4: 2.1.1 “Granular Bedding material used to be in accordance with Section 31 05 16 – Aggregate Materials, and having not more than 10% retained on the 31.5 mm sieve and not more than 10% dust.”
- .5 Division 32 – Exterior Improvements has been updated as follows:
  - .1 Section 32 12 16 – Asphalt Paving has been updated as follows:
    - .1 On Page 5: 2.7.2 “Revised the Asphalt Concrete Mix Design requirements to conform to AASHTO M 323”
    - .2 On Page 11: 3.5.7 “All HMA samples and cores shall be delivered by the Contractor, within 4 hours of sampling, to a Quality Assurance Laboratory designated by the Owner or Consultant.”
    - .3 On Page 11: 3.6.3 “The approved QA testing laboratory shall test a minimum of 2 core samples from the compacted asphalt concrete for laboratory measurement of density and thickness daily.”
  - .2 Added new Section 32 17 23 – Pavement Markings.
  - .3 Section 32 91 20 – Site Restoration has been updated to include the requirements for site restoration other than landscaping, such as driveway restoration and others.
  - .4 Added new Section 32 92 24 – Topsoil, Hydraulic Seeding and Sodding and moved the requirements for landscaping from Section 32 91 20 - Site Restoration to this new section.
- .6 Division 33 – Utilities has been updated as follows:
  - .1 Section 33 14 16 - Water Distribution Piping has been updated as follows:
    - .1 On Page 7: 2.2.3.2 “Mueller MVB composite valve box or approved equal to be complete with 686mm ductile-iron adjustable top, cast iron cover and guide plate.

- .2 On Page 7: 2.2.3.4 "Acceptable products for valve boxes are as follows:
  - .1 Mueller Canada.
  - .2 Approved equivalent."
- .3 On Page 15: "3.8 Tracer Wire Installation... Continuity tests shall be conducted by the Contractor. Testing shall be done in the presence of and to the satisfaction of the Owner and Consultant."
- .4 On Page 17: 3.13.3 "Notify Owner and Consultant at least 24 hours in advance of proposed tests:
  - .1 Perform tests in presence of Owner and Consultant. "
- .5 On Page 18: 3.14.2 "Flushing and disinfecting operations: under witness by Owner and Consultant carried out by specialist contractor.
  - .1 Notify Owner and Consultant at least 4 days in advance of proposed date when disinfecting operations will begin."
- .2 Section 33 31 11 – Sanitary Sewer Gravity Sewer has been updated as follows:
  - .1 On Page 8: 3.8.6.: "Perform tests in presence of Owner and Consultant.
    - .1 Notify Owner and Consultant 24 hours minimum in advance of proposed tests."
- .3 Section 33 31 23 – Sanitary Sewer Force Main has been updated as follows:
  - .1 On Page 10: "3.7 Tracer Wire Installation... Continuity tests shall be conducted by the Contractor. Testing shall be done in the presence of and to the satisfaction of the Owner and Consultant "
  - .2 On Page 11: 3.10.3 "Notify Owner and Consultant at least 24 hours in advance of proposed tests:
    - .1 Perform tests in presence and Owner or Consultant."
- .4 Section 33 42 13 – Pipe Culverts has been updated to read:
  - .1 On page 3: 2.3 "Acceptable Product when approved by Owner"

Part III – Standard Details has been updated as follows:

- .1 Revised 33.SD05 Slide Valve Box (105mm & 130mm) to 33.SD05 MVB Composite Adjustable Valve Box (105mm & 130mm)
- .2 Deleted 33.SD05A Adjustable Valve Box
- .3 Revised 33.SD10 Air Release Valve Chamber to read: "Install Snorkel...or Hood..." and Galvanized Steel Vent Pipe changed to Stainless Steel Vent Pipe.

# TOWN OF QUISPAMISIS



**[CLICK AND TYPE CONTRACT NAME]  
CONTRACT NO.[#]**

April 2026

Rev. No.	Description	Reviewed by:	Date	Issued by:
			[YYYY/MM/DD	

[CLICK AND TYPE DISCIPLINE]: Seal:  
[Engineer Name & Designation]  
Telephone:  
Email:

[CLICK AND TYPE DISCIPLINE]: Seal:  
[Engineer Name & Designation]  
Telephone:  
Email:

[CLICK AND TYPE DISCIPLINE]: Seal:  
[Engineer Name & Designation]  
Telephone:  
Email:

[CLICK AND TYPE DISCIPLINE]: Seal:  
[Engineer Name & Designation]  
Telephone:  
Email:

**END OF SECTION**

<b>Section</b>	<b>Title</b>	<b>No. of Pages</b>
00 00 00	Contract Title Page.....	1
00 01 07	Seals Page.....	1
00 01 10	Table of Contents .....	4

## **PART I – CONTRACT AND GENERAL REQUIREMENTS**

### **Division 00 – Procurement and Contracting Requirements**

00 01 12	Definitions .....	<a href="#">1</a>
00 01 15	Drawing List.....	1
00 21 13	Instructions to Tenderers .....	6
00 41 43	Tender Form .....	3
00 41 43.01	Schedule of Quantities and Unit Prices.....	10
00 42 00	Supplementary Tender Information .....	8
00 53 42	Civil Works Contract - CCDC18-2023 .....	36
00 73 10	Supplementary General Conditions to CCDC18 - 2023.....	6

### **Division 01 – General Requirements**

01 00 00	Project Specific General Requirements.....	16
01 35 29	Project Specific Health and Safety Requirements .....	4
01 35 43	Project Specific Environmental Procedures .....	5
01 95 00	Supplementary Conditions to Standard Specifications.....	1

## **PART II – TECHNICAL SPECIFICATIONS**

### **Division 31 - Earthwork**

31 05 16	Aggregate Materials .....	5
31 11 00	Clearing and Grubbing .....	4
31 23 33.01	Excavating, Trenching, Bedding and Backfill .....	14
31 24 13	Roadway Construction, Embankment and Compaction.....	13
31 37 00	Rip Rap .....	3

### **Division 32 – Exterior Improvements**

32 11 23	Aggregate Placement .....	6
----------	---------------------------	---

32 12 16	Asphalt Paving.....	12
32 16 00	Curbs, Gutters and Sidewalks .....	8
32 17 23	Pavement Markings .....	3
32 31 13	Chain Link Fences and Gates.....	5
32 91 20	Site Restoration .....	4
32 92 24	Topsoil, Hydraulic Seeding and Sodding .....	4

**Division 33 - Utilities**

33 05 16	Precast Concrete Structures .....	7
33 14 16	Water Distribution Piping.....	21
33 31 11	Sanitary Sewer Gravity Piping .....	9
33 31 23	Sanitary Sewer Force Main.....	11
33 41 00	Storm Sewer Piping.....	9
33 42 13	Pipe Culverts .....	7

**Division 34 – Transportation (Various)**

34 71 13.25	Vehicle W-Beam Guide Rail .....	3
-------------	---------------------------------	---

**APPENDIX A – ADDITIONAL TECHNICAL SPECIFICATIONS**

**PART III – STANDARD DETAILS**

<u>Detail No.</u>	<u>Title</u>	
31.SD01	Sediment Control Fence.....	1
31.SD02	Sediment Control Berm .....	1
31.SD03	Sediment Settling Pond .....	1
32.SD01	Utility Restoration Asphalt Concrete T Patch .....	1
32.SD02	Concrete Curb and Gutter .....	1
32.SD03	Concrete Curb and Gutter and Sidewalk .....	1
32.SD03A	Driveway Entrance with Concrete Curb and Gutter and Sidewalk.....	1
32.SD04	Sidewalk Access Ramps.....	1
32.SD05	Chain Link Fence .....	1
32.SD06	Chain Link Security Gate with Vehicle Gate .....	1
32.SD07	Typical Urban Road Cross Section .....	1
32.SD08	Typical Rural Road Cross Section.....	1

32.SD09	Cul-De-Sac.....	1
32.SD10	Angle Intersection .....	1
33.SD01	Single Pipe Trench .....	1
33.SD02	Two Pipe Trench .....	1
33.SD03	Three Pipe Trench .....	1
33.SD03A	Rock Trench Payment Limits .....	1
33.SD04	Fire Hydrant .....	1
33.SD05	MVB Composite Adjustable Valve Box (105mm & 130mm) .....	1
33.SD06	Gate Valve and Chamber .....	1
33.SD07	Tracer Wire Detail .....	1
33.SD08	Chlorination and Flushing.....	1
33.SD09	Concrete Thrust Blocks.....	1
33.SD10	Air Release Valve Chamber .....	1
33.SD11	Water Service Connection .....	1
33.SD12	Valve Chamber Standard Frame and Cover.....	1
33.SD13	Valve Chamber Adjustable Frame and Cover .....	1
33.SD14	Sanitary Manhole.....	1
33.SD15	Interior Drop Manhole .....	1
33.SD16	Sanitary Service Connection .....	1
33.SD17	Standard Sanitary Manhole Frame and Cover .....	1
33.SD18	Sanitary Manhole Adjustable Frame and Cover.....	1
33.SD19	Storm Manhole .....	1
33.SD20	Catch Basin .....	1
33.SD21	Catch Basin at Curb-Curb Gutter.....	1
33.SD22	Storm Service Connection .....	1
33.SD23	Storm Manhole Standard Frame and Cover .....	1
33.SD24	Storm Manhole Adjustable Frame and Cover .....	1
33.SD25	Catch Basin Standard Frame and Flat Grate .....	1
33.SD26	Catch Basin Pyramid Frame and Cover .....	1
33.SD27	Culvert Inlet Grate .....	1
33.SD28	Culvert Outlet Grate.....	1
33.SD29	Pipe Insulation Cover Less Than 1.8m .....	1
34.SD01	Collector 1 – Urban (2 Lane) .....	1
34.SD02	Collector 1 – Urban (3 Lane) with AT Trail.....	1

34.SD03	Collector 1 – Urban (4 Lane) .....	1
34.SD04	Collector 2 – Rural (AADT < 5000).....	1
34.SD05	Collector 2 – Rural (AT Route ≥ 5000 AADT).....	1
34.SD06	Minor Collector (Curbed) .....	1
34.SD07	Minor Collector (Curbed) with Bike Lanes .....	1
34.SD08	Minor Collector (Non-Curbed).....	1
34.SD09	Minor Collector (Non-Curbed AT).....	1
34.SD10	Local.....	1
34.SD11	Local (AT) .....	1
34.SD12	Guide Rail.....	1
34.SD13	Guide Rail termination .....	1

**PART IV – STANDARD FORMS**

**Title**

Watermain Leakage Test Report .....	1
Sanitary Sewer Air Test Report.....	1
Forcemain Leakage Test Report.....	1

**END OF SECTION**

**PART I**  
**CONTRACT AND GENERAL**  
**REQUIREMENTS**

## DEFINITIONS

- .7 **Change Order:** Refer to Definitions from CCDC18-2023.
- .8 **Construction Equipment:** Refer to Definition from CCDC18-2023.
- .9 **Consultant:** Refer to Definition from CCDC18-2023.
- .10 **Contract:** Refer to Definition from CCDC18-2023.
- .11 **Contract Documents:** Refer to Definition from CCDC18-2023.
- .12 **Contract Price:** Refer to Definition from Section 00 73 10 - Supplementary General Conditions.
- .13 **Contract Time:** Refer to Definition from CCDC18-2023.
- .14 **Contractor:** Refer to Definition from CCDC18-2023.
- .15 **Drawings:** Refer to Definition from Section 00 73 10 - Supplementary General Conditions.
- .16 **Professional Engineer or Engineer** means engineer licensed to practice in the province of NB.
- .17 **Owner:** Refer to Definition from CCDC18-2023.
- .18 **Place of the Work:** Refer to Definition from CCDC18-2023.
- .19 **Product:** Refer to Definition from CCDC18-2023.
- .20 **Project:** Refer to Definition from CCDC18-2023.
- .21 **Provide:** Refer to Definition from CCDC18.
- .22 **Shop Drawings:** Refer to Definition from CCDC18-2023.
- .23 **Specifications:** Refer to Definition from CCDC18.
- .24 **Subcontractor:** Refer to Definition from CCDC18-2023.
- .25 **Substantial Performance of the Work:** Refer to Definition from CCDC18-2023.
- .26 **Supplier:** Refer to Definition from CCDC18-2023.
- .27 **Temporary Work:** Refer to Definition from CCDC18-2023.
- .28 **Unit Price:** Refer to Definition from CCDC18-2023.
- .29 **Value Added Taxes:** Refer to Definition from CCDC18-2023.
- .30 **Work:** Refer to Definition from CCDC18-2023.
- .31 **Working Day:** Refer to Definition from CCDC18-2023.
- .32 **Blaster:** means a person who holds a valid certificate of qualification in the blaster occupation or powderman trade issued under the *Apprenticeship and Occupational Certification Act* of New Brunswick.

**END OF SECTION**

**1 DRAWING LIST**

<u>Drawing No.</u>	<u>Description</u>	<u>Revision No.</u>
C00	Cover Sheet	
<u>Civil</u> C01		
<u>Mechanical</u> M01		
<u>Electrical</u> E01		
<u>Structural</u> S01		

**END OF SECTION**

## **1 GENERAL**

### **1.1 INVITATION**

#### **.1 Tender Call:**

- .1 Ensure offers are signed under seal, executed, and dated are received by Owner before [###:##] [a.m./p.m.] local time on [Date] day of [Month], [Year], hereinafter referred to as the Tender Closing.
- .2 Offers submitted after above time will be returned to Tenderer unopened.
- .3 Amendments to submitted offers will be permitted if received in writing [48] hours prior to Tender closing and if endorsed by same party or parties who signed and sealed offer.

### **1.2 TENDER IDENTIFICATION**

#### **.1 Tenders shall be submitted in a sealed envelope marked as follows:**

Tender for:

[Tender Name]

Tender No. [#]

To:

Town of Quispamsis

12 Landing Court, Quispamsis, NB, E2E 4R2

Attention: [Owner Contact]

### **1.3 TENDER DOCUMENTS**

#### **.1 A complete Tender is comprised of the following:**

- .1 The Tender Form in its entirety, with all pages and spaces for entry of information by Tenderers filled in as instructed.
- .2 Acknowledgment of addenda received by the Tenderer during the tendering period.
- .3 Tender Security (refer to clause 1.10.1 herein).
- .4 Consent of Surety/Agreement to Bond (refer to clause 1.11.1 herein).
- .5 WorkSafe NB clearance letter.
- .6 Provincial Certificate of Recognition.
- .7 Supplementary Tender Information provided in Section 00 42 00.

### **1.4 COMPLETION TIME**

- .1 Tenderer, in submitting an offer, accepts time period stated in Contract Documents for performing Work. Completion date in Agreement is completion time added to commencement date.
- .2 Tenderer, in submitting an offer, agrees to complete Work by date indicated in Contract Documents, but may propose a revision to Contract Time with adjustment to Tender price.
- .3 Consideration will be given to time of completion when reviewing Tender submitted.
- .4 Refer to Supplementary General Conditions for inclusion of taxes and procedures for tax rebate claims by Owner.

## **1.5 AVAILABILITY**

- .1 Tender Documents are made available only for purpose of obtaining offers for this project. Their use does not confer license or grant for other purposes.
- .2 Tender Documents can be obtained from the New Brunswick Opportunities Network website.
- .3 Tender Documents are on display at offices of the New Brunswick Construction Association plan room facilities.
- .4 Upon receipt of Tender Documents verify that documents are complete.
- .5 Immediately notify the Owner or Consultant upon finding discrepancies or omissions in Tender Documents.

## **1.6 EXAMINATION OF SITE**

- .1 Before tendering, Tenderers shall have examined the Site of the Work and shall have satisfied themselves as to the working conditions, including labour conditions and labour rules, the nature and kind of work to be done, any special risks associated therewith and all other matters which may be necessary in order to form a proper conception under which the Work will be required to be performed. Tenderers shall not be entitled to claim at any time after execution of the Contract that there was any misunderstanding in regard to all such conditions.
- .2 When forming their estimates and preparing their tenders, Tenderers shall take full cognizance of the content of all the Contract Documents listed in Section 00 41 43 – Tender Form.

## **1.7 QUERIES AND ADDENDA**

- .1 Any ambiguities, inconsistencies, or uncertainties in the Contract Documents which may become apparent to Tenderers when tendering shall be advised in writing to the Owner or Consultant at [Consultant address], Attention: [PM's full name and title], at [PM's email], not less than 7 working days before date set for receipt of Tenders.
- .2 Reply will be in form of an addendum. Copy of addendum will be forwarded to known Tenderers no later than five (5) working days before Tender Closing.
- .3 Verbal answers are only binding when confirmed by written addenda.

- .4 Addenda may be issued during Tender period. Addenda will become part of Contract Documents. Include costs in Tender Price.

## 1.8 VALIDITY

- .1 All tenders shall be valid for acceptance for sixty (60) calendar days from the Closing Date.
- .2 The Civil Works Contract CCDC18 - 2023 is included in the Contract Documents at the time of tendering only for information and shall not be completed at the time of tendering.
- .3 The appending of any qualifying clauses to the tender or failure to comply with these instructions and with all other relevant provisions contained in the documents in the completing of any tender renders such tender liable to disqualification.
- .4 Contract Price to exclude HST. Harmonized sales tax shall be indicated as a separate amount and included in the Total Amount Payable.

## 1.9 AMENDMENT/WITHDRAWAL

- .1 Tenders may be amended or withdrawn by email to [quispamsis@quispamsis.ca](mailto:quispamsis@quispamsis.ca), prior to Tender Closing. Amendments shall not disclose either original or revised total price.
- .2 Label amendment or withdrawal email as follows: “[Amendment]/[Withdrawal]” of Tender for the “Town of Quispamsis, [Tender Name], [Tender No.]”. Sign and seal as required for tender and submit at address given for receipt of tenders. All Submissions must be received prior to Tender Closing.

## 1.10 TENDER SECURITY

- .1 Each tender shall be accompanied by Tender Security in the amount of ten percent (10%) of the Total Amount Payable in evidence of the bona fide nature of the tender. This Tender Security shall be in favour of the Owner and shall be in the form of a Certified Cheque, Irrevocable Letter of Credit or a Bid Bond which shall guarantee to the Owner that in the event of the successful Tenderer declining to enter into a formal agreement with the Owner as called for in the Contract Documents, or declining or neglecting to provide the Insurance or Contract Security required by the Contract Documents, then the Owner will be reimbursed the additional cost of accepting another tender or Tender Security amount, whichever is the lesser.
- .2 The bonds shall be issued by a company whose guaranteed bonds are acceptable to the Government of Canada. Use latest edition of CCDC Form 220.
- .3 The Tender Security of the unsuccessful Tenderers will be returned to them after the Owner enters into a formal agreement with the successful Tenderer or the expiration of validity of their tenders, whichever is the sooner.
- .4 If no contract is awarded, Tender Security will be returned.

## 1.11 CONSENT OF SURETY/AGREEMENT TO BOND

- .1 Submit with Tender Form and Bid Bond, [Consent of Surety] [Agreement to Bond], stating

that surety providing Bid Bond is willing to supply Performance and Labour and Materials Payment Bond specified.

- .2 Include cost of bonds in Tender Price.

### **1.12 INSURANCE**

- .1 Provide signed "Undertaking of Insurance" on standard form provided by insurance company stating intention to provide insurance to Tenderer in accordance with insurance requirements of Contract Documents.

### **1.13 ACCEPTANCE/REJECTION**

- .1 On the written acceptance by the Owner of a tender, that tender becomes the Contract and the Tenderer who has submitted it becomes the Contractor. The Contractor will be required to enter into a formal agreement with the Owner following receipt of a written notice of acceptance from the Owner. The written notice of acceptance forms a Contract Agreement until the formal "Agreement" is executed.
- .2 Within seven (7) days of written acceptance of a tender that tender shall provide Contract Security in the amount and form as specified in GC11.2 and as supplemented in Section 00 73 10 – Supplementary General Conditions, and Insurance as specified in GC11.1.
- .3 Complete the Tender Form in ink or typewritten and have corrections initialled by the individual signing the tender.
- .4 Where manufactured articles are described or specified in the Contract Documents by name, catalogue number of a manufacturer or supplier, Tenderers shall tender on the basis of using only such articles. Procedure concerning substitution of a specified article with another shall be in accordance with equivalents and alternates in Section 01 00 00 – Project Specific General Requirements.
- .5 The Owner will not defray any expenses whatsoever incurred by Tenderers in the preparation and submission of their tenders. The Owner reserves the right to waive any formality or technicality in any tender.
- .6 The Owner reserves the right to accept or to reject any or all tenders received, or to select a tender which is deemed by the Owner to be in its best interests.
- .7 Tenders, which in the opinion of the Owner are considered to be informal or unbalanced, may be rejected.

### **1.14 PRODUCT SUBSTITUTIONS**

- .1 Where Tender Documents stipulate a particular product, substitutions will be considered up to 7 days before receipt of Tenders.
- .2 When request to substitute product is made, Owner or Consultant may approve substitution and will issue Addendum to known Tenderers.
- .3 In submission of substitutions to products specified, Tenderers are to include in their Tender changes required in Work to accommodate such substitutions. Later claims by Tenderer for addition to Contract Price as a result of changes in Work necessitated by use

of substitutions will not be considered.

- .4 Substituted products will be considered during the tender period.
- .5 Ensure submission provides sufficient information to enable Owner to determine acceptability of such products.
- .6 Provide complete information on required revisions to other work to accommodate each substitution, dollar amount of additions to or reductions from Tender Price, including revisions to other work.
- .7 Provide specified products unless substitutions are submitted as noted and subsequently accepted.
- .8 Approval to submit substitutions prior to submission of Tender is not required.

### **1.15 TENDER SIGNING**

- .1 Tender Form to be signed under seal by Tenderer.
- .2 Sole Proprietorship: signature of sole proprietor in presence of witness who shall also sign. Insert words "Sole Proprietor" under signature. Affix seal.
- .3 Partnership: signature of all partners in presence of witness who shall also sign. Insert word 'Partner' under each signature. Affix seal to each signature.
- .4 Limited Company: signature of duly authorized signing officer(s) in normal signatures. Insert officer's capacity in which signing officer acts, under each signature. Affix corporate seal. If Tender is signed by officials other than President and Secretary of company, or President-Secretary-Treasurer of company, copy of by-law resolution of Board of Directors authorizing them to do so must also be submitted with Tender in Tender envelope.
- .5 Incorporated Company: signature of duly authorized signing officer(s) in normal signatures. Insert officer's capacity in which signing officer acts, under each signature. Affix corporate seal. If Tender is signed by officials other than President and Secretary of company, or President-Secretary-Treasurer of company, copy of by-law resolution of Board of Directors authorizing them to do so must also be submitted with Tender in Tender envelope.
- .6 Joint Venture: each party of joint venture must execute Tender under respective seals in manner appropriate to such party as described above, similar to requirements of Partnership.

### **1.16 PRESELECTED/PREPURCHASED EQUIPMENT**

- .1 The Tenderers shall take note that the Owner has pre-selected/pre-purchased certain items of equipment for incorporation into the Work by the Contractor. Procedures for taking over pre-selected/pre-purchased equipment are specified in Section 01 00 00 – Project Specific General Requirements. Copies of the pre-selected/pre-purchased equipment shop drawings or other information is available for viewing at the office of the Owner or Consultant.

### **1.17 LIQUIDATED DAMAGES**

- .1 The Owner and the Contractor will agree that, in the event that the Work, or portions of the Work, as identified in the Contract Documents, are not completed substantially as specified in the Contract Documents that the Owner will suffer damages, which are difficult to identify with precision because of the nature of the project. The Contractor and the Owner agree that a fair pre-estimate of the amount of set damages is five hundred dollars (\$500.00) per calendar day for the first fifteen (15) calendar days. The amount is one thousand dollars (\$1,000.00) per calendar day for every day after the first fifteen (15) calendar days. Therefore, the parties agree that the Contractor shall pay to the Owner for each and every calendar day after the identified Contract completion date, the sum of five hundred dollars (\$500.00), and one thousand dollars (\$1,000.00) per calendar day after that, as determined by the parties hereto to be liquidated damages, not a penalty. These damages will be deducted from the contract amount.

**END OF SECTION**

**1 GENERAL**

**1.1 SALUTATION**

.1 TO:

Town of Quispamsis  
12 Landing Court  
Quispamsis, NB E2E 4R2

.2 FOR:

Contract Name: \_\_\_\_\_

Contract No.: \_\_\_\_\_

.3 FROM:

\_\_\_\_\_  
\_\_\_\_\_  
\_\_\_\_\_

**1.2 TENDERER DECLARES**

.1 That this tender was made without collusion or fraud.

.2 That the proposed work was carefully examined.

.3 To have personal knowledge of the location of the proposed Work and is informed as to the actual conditions and requirements, including labour conditions and labour rules and shall not claim at any time after execution of the Agreement that there was any misunderstanding in regard to such conditions and requirements.

.4 That Contract Documents and Addenda No. \_\_\_\_ to \_\_\_\_ inclusive were carefully examined.

.5 That all the above were taken into consideration in preparation of this Tender.

**1.3 TENDERER AGREES**

.1 To enter into a contract to supply all labour, material and equipment and to do all work necessary to construct the Work as described and specified herein for the unit prices stated in Subsection 4 hereunder, Schedule of Quantities and Unit Prices.

.2 That the estimated Contract Price shall be the sum of the products of the tendered unit prices times the estimated quantities in Subsection 4 hereunder.

.3 That this Tender is valid for acceptance for sixty (60) days from the time of Tender Closing.

- .4 That measurement and payment for items listed in Subsection 4 hereunder shall be in accordance with corresponding items in the General Specification.
- .5 Upon request to provide evidence of ability and experience within seven (7) days of request, including experience in similar work, work currently under contract, senior supervisory staff available for the project, equipment available for use on the Work, and financial resources.
- .6 To execute in triplicate the Agreement and forward same together with the specified contract security and insurance documents to the Owner within fourteen (14) days of written notice of award.
- .7 That failure to enter into a formal contract and give specified insurance documents and tender security within time required will constitute grounds for forfeiture of certified cheque or enforcement of bid bond.
- .8 That if certified cheque is forfeited, Owner will retain difference in money between amount of Tender and amount for which Owner legally contracts with another party to perform the Work and will refund balance, if any, to Tenderer.
- .9 Declares to have carefully examined the documents and Addenda No .\_\_\_\_\_ to \_\_\_\_\_ referred to in the first paragraph of this Tender Form, and the Tenderer hereby accepts and agrees to the same as forming a part of the Contract.
- .10 Understands that in the event that the tendered Contract Price is not within the project budget, the Owner has the right to negotiate the Contract with the low bidder or reject all tenders received.
- .11 Agrees that the Warranty Period defined in the Contract Documents shall be for a period of one (1) year from the date of Substantial Performance of the Work.
- .12 Understands that Substantial Performance of the Work will be established in accordance with General Conditions of the Contract and applicable lien legislation.
- .13 Understands that after the issuance of the certificate of Substantial Performance of the Work by the Consultant, provided that the Contractor has relieved the Owner from any and all claims, demands and lien claims for and in respect of the Contract, and has completed all outstanding items and corrected all deficiencies, the Contractor shall submit an application for Final Payment and the Owner or Consultant will thereafter prepare the Final Certificate for payment in accordance with the General Conditions of the Contract and applicable lien legislation.
- .14 Understands that the payment of holdback will be in accordance with the General Conditions of the Contract and subject to the provisions of the lien legislation applicable to the Place of Work.
- .15 Understands the occupational Health and Safety Legislation and any Workers or Workplace compensation legislation applicable to the Place of the Work and declares that they are in good standing and have all necessary certification as required by such legislation.
- .16 Agrees that time shall be construed as being of the essence of the Contract.
- .17 That the Contract Documents include:
  - .1 Drawing List.
  - .2 Tender Form.
  - .3 Supplementary Tender Information.

- .4 Civil Works Contract - CCDC18 – 2023.
- .5 Supplementary General Conditions to CCDC18 – 2023.
- .6 Supplementary Technical Specifications.
- .7 Drawings:
  - Drawing. No.      Title
  
- .8 [Appendices]
- .9 Addenda as issued and as confirmed in Subsection 1.2.4 of this Section.

**1.4 SCHEDULE OF QUANTITIES AND UNIT PRICES**

**1.5 COMPLETION TIME**

.1 Tenderer agrees to start on-site construction by Month, Day, Year and complete Substantial Performance of the Work on or before Month, Day, Year.

**1.6 SIGNATURE \***

Dated this \_\_\_\_ day of \_\_\_\_, 20\_\_\_\_.

\_\_\_\_\_  
Name of Firm Tendering

\_\_\_\_\_  
Signature of Signing Officer

\_\_\_\_\_  
Witness

\_\_\_\_\_  
Name and Title (Printed)

\_\_\_\_\_  
Name and Title (Printed)

\_\_\_\_\_  
Signature of Signing Officer

\_\_\_\_\_  
Witness

\_\_\_\_\_  
Name and Title (Printed)

\_\_\_\_\_  
Name and Title (Printed)

\_\_\_\_\_  
Company Address

\_\_\_\_\_  
Telephone No.

\_\_\_\_\_  
Fax No.

[Seal]

\*NOTE: Tenders submitted by or on behalf of any Corporation must be signed and sealed in the name of such Corporation by a duly authorized officer or agent.

**END OF SECTION**

The information requested in this section is a requirement of the tender submission and is to be completed and submitted with Section 00 41 43 - Tender Form.

.1 Referee as to Tenderer's financial status:

Name: \_\_\_\_\_

Address: \_\_\_\_\_

Contact: \_\_\_\_\_

Telephone: \_\_\_\_\_

.2 Name and address of company who has agreed to underwrite the Bonds for Performance and for Labour and Material Payment. Refer to Clause GC 11.2 – Contract Security in the General Conditions.

Name: \_\_\_\_\_

Address: \_\_\_\_\_

Telephone: \_\_\_\_\_

.3 Name and address of company who has agreed to underwrite insurance on this Contract and the type and amount of insurance. Refer to Clause GC 11.1 – Insurance in the General Conditions.

Name: \_\_\_\_\_

Address: \_\_\_\_\_

Telephone: \_\_\_\_\_

Type of Insurance	Amount
_____	\$ _____
_____	\$ _____
_____	\$ _____
_____	\$ _____
_____	\$ _____

.4 Particulars of Tenderer's recent contracts:

.1 The Tenderer shall furnish particulars of at least three, and if possible, five contracts successfully completed or currently being carried to completion. The projects quoted should preferably be approximate in nature to the Works now tendered for and be of comparable or greater size.

Owner: \_\_\_\_\_

Project Description: \_\_\_\_\_

Start Date: \_\_\_\_\_

Finish Date: \_\_\_\_\_

Contract Value \$ \_\_\_\_\_

Owner: \_\_\_\_\_

Project Description: \_\_\_\_\_

Start Date: \_\_\_\_\_

Finish Date: \_\_\_\_\_

Contract Value \$ \_\_\_\_\_

Owner: \_\_\_\_\_

Project Description: \_\_\_\_\_

Start Date: \_\_\_\_\_

Finish Date: \_\_\_\_\_

Contract Value \$ \_\_\_\_\_



.7 List of Sub-contractors to be used:

- .1 The Tenderer's attention is drawn to the General Conditions GC 3.8 – Subcontractors and Suppliers. The Tenderer shall enter the name and address of each Sub-Contractor used in making up the tender. Only one Sub-Contractor shall be named for each part of the Work to be sublet.
- .2 After the tender has been accepted by the Owner, the Contractor shall not be allowed to substitute other sub-contractors in place of those named in the tender without written approval from the Consultant.

Sub-Trade: \_\_\_\_\_

Contractor Name & Address: \_\_\_\_\_

Scope of Work: \_\_\_\_\_

Value of Work: \$ \_\_\_\_\_

Sub-Trade: \_\_\_\_\_

Contractor Name & Address: \_\_\_\_\_

Scope of Work: \_\_\_\_\_

Value of Work: \$ \_\_\_\_\_

Sub-Trade: \_\_\_\_\_

Contractor Name & Address: \_\_\_\_\_

Scope of Work: \_\_\_\_\_

Value of Work: \$ \_\_\_\_\_

Sub-Trade: \_\_\_\_\_

Contractor Name & Address: \_\_\_\_\_

Scope of Work: \_\_\_\_\_

Value of Work: \$ \_\_\_\_\_

Sub-Trade: \_\_\_\_\_

Contractor Name & Address: \_\_\_\_\_

Scope of Work: \_\_\_\_\_

Value of Work: \$ \_\_\_\_\_

.8 Project personnel:

- .1 The Tenderer shall include below, the names, qualifications and previous experience of those people who will be directly involved with the project. The names shall, for example, include Site supervisor, superintendent contractor's engineer and or construction manager.

Name: \_\_\_\_\_

Position: \_\_\_\_\_

Years of Experience: \_\_\_\_\_ Years with Company: \_\_\_\_\_

Related Experience: \_\_\_\_\_

Name: \_\_\_\_\_

Position: \_\_\_\_\_

Years of Experience: \_\_\_\_\_ Years with Company: \_\_\_\_\_

Related Experience: \_\_\_\_\_

Name: \_\_\_\_\_

Position: \_\_\_\_\_

Years of Experience: \_\_\_\_\_ Years with Company: \_\_\_\_\_

Related Experience: \_\_\_\_\_

Name: \_\_\_\_\_

Position: \_\_\_\_\_

Years of Experience: \_\_\_\_\_ Years with Company: \_\_\_\_\_

Related Experience: \_\_\_\_\_

Name: \_\_\_\_\_

Position: \_\_\_\_\_

Years of Experience: \_\_\_\_\_ Years with Company: \_\_\_\_\_

Related Experience: \_\_\_\_\_

.9 Tenderer's Safety Data

.1 The Owner is committed to working with safe contractors. Before the Tenderer or the Tenderer's subcontractor is allowed to work, safety performance will be reviewed by the Owner. The Owner requires that all Tenderers and subcontractors be registered and in good standing with the WorkSafeNB.

.2 Recordable Incidents:  
Indicate Tenderer's WorkSafeNB registration number. \_\_\_\_\_

.3 Using the Tenderer's last year's Accident Statements, complete the following:

- .1 Number of injury related fatalities: \_\_\_\_\_
- .2 Number of injuries with lost workdays: \_\_\_\_\_
- .3 Number of injuries requiring medical attention, but no lost work days: \_\_\_\_\_

Note: No "First Aid" cases should be included in the above.

.4 Number of "First Aid" cases in addition to above: \_\_\_\_\_

.5 Number of employee hours worked last year:

Field: \_\_\_\_\_

Supervisory: \_\_\_\_\_

Total: \_\_\_\_\_

.4 Safety Program:

.1 Do you hold safety meetings for:

	<u>Yes</u>	<u>No</u>	<u>Frequency</u>	<u>Title of Person Conducting Meeting</u>
Employees	_____	_____	_____	_____
Subcontractors	_____	_____	_____	_____

Do you conduct job safety inspections? Yes: \_\_\_\_\_ No: \_\_\_\_\_

Do you have a formal safety program? Yes: \_\_\_\_\_ No: \_\_\_\_\_

.10 Who will be your designated safety contact person on Site? \_\_\_\_\_

.11 List the names of those employees who will be on the Owner's Site that are certified in first aid. (Attach a separate list, if necessary.)

<u>Employee Name</u>	<u>Expiry Date of Certificate</u>
_____	_____
_____	_____
_____	_____
_____	_____
_____	_____
_____	_____
_____	_____

This is to certify that the data and information provided is accurate. It also gives permission to the Owner to verify the above information with WorkSafeNB.

Signature\_\_\_\_\_

Name\_\_\_\_\_

Title\*\_\_\_\_\_

Date\_\_\_\_\_

\* President or senior company officer.

**END OF SECTION**

CIVIL WORKS CONTRACT  
CCDC18 - 2023

THESE SUPPLEMENTARY GENERAL CONDITIONS AMEND THE DEFINITIONS AND GENERAL CONDITIONS OF THE CIVIL WORKS CONTRACT – CCDC18 – 2023.

### **AGREEMENT BETWEEN OWNER AND CONTRACTOR**

Page 1, add the following to Article A-1 after: "is acting as and is hereafter called the "Consultant" and,

Owner is acting as and is hereafter called the "Payment Certifier"

### **DEFINITIONS**

Page 6, delete Definition 7, **Contract Price**, and replace with the following new definition:

"The Contract Price shall be the sum of the products of the actual final quantities that are incorporated in, or made necessary by the Work, as confirmed by count and measurement, multiplied by the appropriate Unit Prices from the Tender Form together with any adjustments that are made in accordance with the provisions of the Contract Documents plus the amount of Harmonized Sales Tax."

Page 6, Definition 10, **Drawings**, add the following sentence:

"Drawings shall be stamped by a Professional Engineer licensed to practice in the province of NB."

Page 6, Definition 12, **Place of Work**, add the following sentence:

"Any reference within the Contract Documents to the term "Site" shall be considered interchangeable with the definition "Place of the Work".

Page 7, Definition 21, Supplemental Instruction, and elsewhere in the document, change "**Supplemental Instruction**" to read "**Site Instruction**".

Page 7, Add new definitions as follows:

28. "**Approved**" or "**Approval**": means acceptance by the Consultant in accordance with the Consultant's responsibilities described in Clause GC 2.2 ROLE OF THE CONSULTANT.
29. "**Total Amount Payable**" means the sum of the Contract Price in the Tender Form, subject to adjustments made in accordance with the provisions of the Contract Documents plus the amount of Value Added Taxes.
30. "**Period of Delay**" The period of time from the date stated in the Agreement and the actual date of Substantial Performance; if any.

31. **“Project Documents”** Project Documents are those documents prepared to supplement the Standard Specifications for the Work on a specific Project. Where applicable, they consist of the Information for Tenderers, Tender Form, Form of Agreement, Technical Specifications, drawings and addenda.
32. **“Site”** The Site means the geographical location of the Work identified in the Contract Documents and has the same meaning as Place of Work.
33. **“Pre-Purchased Equipment Supplier”** A Pre-Purchased Equipment Supplier means a firm or corporation with whom the Owner has entered into a contract for the supply of equipment and has placed a purchase order for equipment to be installed by the Contractor in the Work.
34. **“Pre-Selected Equipment Supplier”** A Pre-Selected Equipment Supplier means a firm or corporation with whom the Contractor shall enter into a contract with and place a purchase order to supply the equipment as Pre-Selected by the Owner, for incorporation into the Work.”

## **GENERAL CONDITIONS OF CIVIL WORKS CONTRACT**

### **PART 2 ADMINISTRATION OF THE CONTRACT**

#### **GC 2.4 – DEFECTIVE WORK**

Page 11, clause 2.4.3, add the following sentence at the end of the clause:

“If the Owner or Consultant determination is not accepted by either party, then the matter shall be settled in accordance with the requirements of Part 8 of the General Conditions – DISPUTE RESOLUTION.”

### **PART 3 EXECUTION OF THE WORK**

#### **GC 3.4 - CONSTRUCTION SCHEDULE**

Page 12, clause 3.4.1.1, delete “prior to the first application for payment, ...” and replace with “not later than two (2) weeks after Contract Award,...”

#### **GC 3.6 – LAYOUT OF THE WORK**

Page 12, delete clause 3.6.1 in its entirety and replace with the following:

“3.6.1 The Contractor shall have all reference points established on Site by a licensed surveyor, at the place of the Work, at no additional cost to the Owner.”

#### **GC 3.7 – SUBCONTRACTORS AND SUPPLIERS**

Page 13, after clause 3.7.6, add the following:

"3.7.7 A copy of the Contract or Agreement between the Contractor and any of his subcontractors shall be provided to the Consultant, if required."

## **PART 5 PAYMENT**

### **GC 5.5 – PROGRESS PAYMENT**

Page 15, after clause 5.5.2, add the following additional clause:

"5.5.3 The Contractor shall agree interim quantities with the Consultant for the purposes of progress payment claims, prior to submission of progress payment application.

"5.5.4 The Contractor shall pay promptly any and all accounts for labour, services and materials used for the purpose of the fulfillment of this Contract as and when such accounts become due and payable and shall furnish the Consultant with proof of payment of such accounts in such form and as often as the Consultant may request."

### **GC 5.6 - SUBSTANTIAL PERFORMANCE OF THE WORK AND PAYMENT OF HOLDBACK**

Page 15, after clause 5.6.1.2, add the following:

"5.6.1.3 Submit a certificate by deed search to the Owner by a solicitor qualified to practice law in the Province of the Place of Work, certifying that no lien associated with the Work exists against the Owner's property or Work.

5.6.1.4 Submit a clearance letter from WorkSafe NB.

5.6.1.5 All such documents shall be dated not earlier than the expiry of the lien period."

Page 15, after clause 5.6.6, add the following additional clause:

"5.6.7 Fifteen (15) days before the Contractor submits the application for Substantial Performance of the Work, all Operations and Maintenance Manual materials shall be submitted to the Consultant in accordance with the Contract Documents. The Certificate of Substantial Performance will not be issued until the Consultant received the required documents."

"5.6.8 If, within 60-days after the issue by the Consultant of the Certificate of the Substantial Performance, the Contractor has not corrected all the deficiencies, the Owner shall retain sufficient money to cover the cost of completing said deficiencies, as determined by the Consultant, in addition to holding monies retained in accordance with the provisions of this Contract and subject to the provisions of the *Construction Remedies Act* lien legislation of New Brunswick."

### **GC 5.7 – FINAL PAYMENT**

Page 15, delete clause 5.7.1 in its entirety and replace with the following:

"5.7.1 When the Contractor considers that the Work is completed, the Contractor shall submit an application for final payment. The Contractor's application for final payment is considered to be valid when:

- .1 Work has been completed in compliance with the Contract Documents and the Consultant is satisfied that all the requirements of the Contract have been fulfilled by the Contractor.
  - .2 Defects have been corrected and deficiencies have been completed.
  - .3 Equipment and systems have been tested, adjusted and balanced and are fully operational and written reports as outlined in the Contract Documents have been provided to the Consultant.
  - .4 Certificates required by utility companies, manufacturer's representative and inspectors have been submitted.
  - .5 Spare parts, maintenance materials, warranties and bonds have been provided.
- 5.7.2 If Work is deemed incomplete by the Consultant, complete outstanding items and request re-inspection.
- 5.7.3 If, in the opinion of the Consultant, it is not expedient to correct defective work or work is not performed in accordance with the requirements of the Contract, the Owner may deduct from the Contract Price the difference in value between work performed and that called for by the Contract Documents, the amount of which shall be determined by the Consultant."

Page 16, renumber existing clauses 5.7.2, 5.7.3 and 5.7.4 to 5.7.4, 5.7.5, and 5.7.6 respectively. In renumbered clause 5.7.6, change "5 calendar days" to read "20 calendar days".

## **PART 6 CHANGES**

### **GC 6.2 – CHANGE ORDER**

Page 16, add new clause 6.2.4 and 6.2.5 as follows:

- "6.2.4 If the method of adjustment of the Contract Price presented by the Contractor is a lump sum or a unit price quotation as indicated in 6.2.2.2, the mark-up on changes shall be as follow:
- .1 Direct basic wages paid for labour including machine operators and foremen (excluding on Site or office supervisory staff) required to perform the Work in accordance with directions and devoting their exclusive attention to this work.
  - .2 Twenty five percent (25%) of item (6.2.4.1) which shall be considered to cover the cost of small tools, on Site or office supervisory staff, WorkSafe NB, holiday pay, payments, Employment Insurance, insurance premiums, and all other payroll overheads.
  - .3 The necessary cost to the Contractor of the material required for the Works as furnished by the Contractor and delivered to the Site.
  - .4 Fifteen percent (15%) of the sum of items (6.2.4.1), (6.2.4.2), and (6.2.4.3), which shall be considered as covering the Contractor's overhead expense, profit, head office and Site office overhead, including salaries of time-keeping, clerical, accounting, warehousing and other administrative personnel and all costs associated therewith.
  - .5 Rental of Construction Equipment: The equipment rental rates shall be in

accordance with equipment rental rates indicated in the latest edition of Roadbuilders' Equipment Rates. In the absence of Roadbuilders' Equipment Rates, New Brunswick Department of Transportation and Infrastructure (NB DTI) rates shall govern.

- 6.2.5 The price for extra, additional or omitted work shall be based on the sub-contractor's approved invoice plus 10 percent (10%) of the amount of this invoice, which shall be considered as covering all the Contractor's expenses and profit. A subcontractor who enters into an agreement with the Contractor to furnish labour and equipment and/or to perform work, which normally would be performed by the Contractor, shall not be considered as an approved sub-contractor for the purpose of valuation of variations, and the Contractor shall not be entitled to 10 percent (10%) of the other Contractor's invoice."

### **GC 6.5 – DELAYS**

Page 18, clause 6.5.2, delete last sentence of paragraph and replace with the following sentence:

"The Contractor will not be reimbursed by the Owner for costs incurred by the Contractor as a result of such delay."

## **PART 7 DEFAULT NOTICE**

### **GC 7.3 - SUSPENSION OF WORK**

Page 21, add new clause GC 7.3 as follows:

- "7.3.1 The Contractor shall obtain the written permission of the Consultant before making any interruptions to the agreed program of works.
- 7.3.2 The Consultant may, by an order in writing, at any time stop or suspend any part of the Work, or direct any portion to be commenced or completed in priority to any other part or portion, or may cancel the order to proceed with the Work, or with any part thereof, and the Contractor shall not thereby be entitled to any additional payment, or claim for loss of profit or anticipated profit, or for damages or otherwise howsoever, by reason of such order. When, in the opinion of the Consultant, for any reason, it is deemed advisable to discontinue the Work, or any part thereof, the Contractor must, on written notice from the Consultant, forthwith place the Work in proper and satisfactory condition for the accommodation of the public and for its effectual protection against damage from rain, snow, frost, ice, or other causes and must so maintain it."

## **PART 10 GOVERNING REGULATIONS**

### **GC 10.1 – TAXES AND DUTIES**

Page 25, after clause 10.1.2, add the following:

- "10.1.3 The Contractor shall indicate on each application for payment, as a separate amount, the appropriate Harmonized Sales Tax that the Owner is legally obliged to pay. This

amount will be paid to the Contractor in addition to the amount certified for payment under the Contract.”

**GC 10.2 – LAWS, NOTICES, PERMITS AND FEES**

Page 25, in paragraph 10.2.2, add new sentences to end of paragraph as follows:

“Various jurisdictions have requirements for posting non-refundable fees before excavations are carried out within public rights-of-way. The Contractor is responsible for the determination of the requirement for each specific project and for any required deposits.”

**END OF SECTION**

## **1 GENERAL**

### **1.1 SUMMARY OF WORK**

- .1 Work of this Contract generally includes, but is not necessarily limited to, the [Description of the Work].

### **1.2 DATUM**

- .1 All elevations shown on the Drawings are referred to the Canadian Geodetic Datum (CGVD28). Verify all elevations prior to commencing Work.

### **1.3 REFERENCES AND CODES**

- .1 Perform Work in accordance with the latest adopted edition of the National Building Code (NBC), National Fire Code (NFC) 2010, National Plumbing Code (NPC) and/or any other code of provincial or local application.
- .2 Reference has been made to certain Domestic, National and International Standards throughout the various sections of the Specification contained herein. These Standards will be considered an integral part hereof and shall be read in conjunction with the Drawings and Specifications as if they were reproduced herein. Be completely familiar with their contents and requirements.

### **1.4 SETTING OUT THE WORK**

- .1 No construction of Work shall commence until all required drawings have been submitted and reviewed and accepted by the Owner or Consultant.
- .2 Before the Work of the Contractor starts, the Owner or Consultant will only provide the data for sufficient reference points once to identify the Site on the ground. Contractor shall have reference points established on-Site by a licensed surveyor at own cost. Contractor shall maintain these, and/or re-establish points as required during the Contract period.
- .3 Before commencing any Work, agree to all levels of the original ground surface with the Owner or Consultant.

### **1.5 COST BREAKDOWN**

- .1 Before submitting first progress claim, submit detailed breakdown of price as directed by Owner or Consultant. After approval by Owner or Consultant, cost breakdown will be used as the basis for progress payments.

## **1.6 WORK BY OTHERS**

- .1 Co-operate with other Contractors in carrying out their respective Works and carry out instructions from Owner or Consultant.
- .2 If any part of Work under this Contract depends upon Work of another contractor, for its proper execution or result, report promptly to Owner or Consultant, in writing, any defects which may interfere with proper execution of Work.
- .3 Verify Work by other contractors which will be executed before start of the Work of this Contract, and which is specifically excluded from this Contract.

## **1.7 SUBMITTALS**

- .1 Construction schedule:
  - .1 As soon as it is practicable, in any case not later than ten (10) Working days after the start of the Contract, submit to the Owner or Consultant for review and approval, a program and construction schedule showing the order of procedure, significant Contract dates, and method in which the Contractor proposes to carry out and complete the Work within time period required by Contract Documents.
  - .2 Provide information regarding the execution of the Work and of the equipment for Temporary Works, and labour which the Contractor intends to supply, use or construct as the case may be.
  - .3 The construction schedule shall be standard "bar" type, showing commencement, duration and completion of activities of all trades and suppliers involved.
  - .4 The construction schedule is subject to review by Owner or Consultant and shall be revised and resubmitted as directed.
  - .5 The construction schedule shall identify activities and Work of other contractors, or the Owner, required for full execution and coordination of the Work.
  - .6 Update schedules periodically and submit updated construction schedule two (2) days prior to routine construction meetings held with Owner or Consultant. Where Work has fallen behind the original schedule times, indicate methods proposed to correct such loss of time, to maintain the stated Completion Time.
- .2 Shop Drawings:
  - .1 The Owner or Consultant will provide a shop drawing list with IDs. Shop drawings are to have an ID written on them.
  - .2 Submit shop detail or Working drawings and manufacturer's data for all items requiring fabrication, on or off the Site, and for all proprietary equipment to the Owner or Consultant for review before any such items or equipment are incorporated into the Works. This review of Shop Drawings by Owner or Consultant is for the sole purpose of ascertaining conformance with the general design concept. This review shall not mean that Owner or Consultant approves the detailed design inherent in the Shop Drawings. Responsibility for the design will remain with the Contractor submitting them, and such review shall not relieve the Contractor of responsibility for errors or omissions in Shop Drawings or of responsibility for meeting all requirements of the Construction and Contract Documents. The Contractor is responsible for dimensions to be confirmed and correlated at the job Site, for information that pertains solely to

fabrication processes or to techniques of construction and installation, and for coordination of the Work of all sub-trades.

- .3 Submit one (1) electronic file in pdf file format of all relevant shop drawings to the Owner or Consultant. Upon approval of the Owner or Consultant, submit four (4) hard copies of shop drawings. For electronic submittals only submit one complete copy file, multiple PDF files for one item will not be accepted. An FTP Site can be set up for shop drawing submittals if required.
  - .4 Submit shop drawings with such promptness as not to cause delay in this Work, or of the Works of any Sub-contractors.
  - .5 The information submitted shall clearly show the dimensions, materials or construction, performance, finish, service and installation requirements and other characteristics in sufficient detail to permit the Owner or Consultant to evaluate the suitability of the articles for the use intended.
  - .6 Make corrections required by the Owner or Consultant as noted, and resubmit corrected copies to the Owner or Consultant for review before fabrication.
  - .7 If electronic files are received by the Owner or Consultant, they will markup and return one (1) electronic file. If paper copies are received the Owner or Consultant will retain three (3) copies of each drawing or document submitted and will mark comments on up to three (3) more copies for the Contractor's purposes. The Owner or Consultant may choose to convert the paper copies into PDF and return one (1) electronic copy to the Contractor.
  - .8 The Owner or Consultant will not review shop drawings and other material involving a large amount of Work in those instances where it is evident that the Contractor has not used all the information contained in, or where such details are obviously not consistent with the Contract Documents.
- .3 Operation and Maintenance Manuals:
- .1 Provide to the Owner certificates from the manufacturers of the equipment incorporated into the Works (or from their accredited agents) stating that their qualified representatives have tested the equipment which they supplied and have found everything to be satisfactorily installed and in proper Working order.
  - .2 Provide four (4) hard copy sets and one (1) electronic file in pdf file format of operations, installation and maintenance information for each system. Provide two (2) of the sets to the Owner or Consultant not less than four (4) weeks prior to commissioning. Obtain additional copies of installation and start-up instructions as required at no additional expense to the Contract.
  - .3 All such material must be new material. Photocopies of literature provided by manufacturers will not be accepted. Drawings to be unfolded and page size papers to be unperforated at the binding edge if possible.
  - .4 The Certificate of Substantial Performance will not be issued until this material has been completely provided.
- .4 Commissioning Plan:
- .1

## 1.8 MEETINGS

- .1 Start-up Meeting:
  - .1 Within five (5) Working days after notification of intent to award a Contract, and before any Work commences onsite, request a meeting of parties to discuss and resolve administrative procedures and responsibilities.
  - .2 Owner, Consultant, Contractor, and major subcontractors are to be the parties in attendance.
  - .3 Establish time and location of meeting.
  - .4 Bring to the meeting the Contract for execution.
  - .5 Provide the agenda and record of minutes of the meeting. Agenda to include the following:
    - .1 Appointment of official representative of participants in the Work.
    - .2 Establish project coordination meeting frequency and required attendees.
    - .3 Schedule of Work, showing key milestones such as equipment/material delivery dates and substantial completion date.
    - .4 Schedule of submission of shop drawings, samples and finish samples.
    - .5 Requirements for temporary facilities, Site sign, office, storage sheds, utilities, fences and laydown area.
    - .6 Security requirements will be reviewed.
    - .7 Discuss process for payment clauses, changes and other administrative requirements.
    - .8 Owner-furnished products.
    - .9 Insurance certificates and permits.
    - .10 Hours of Work and Site supervision requirements.
- .2 Progress Meetings:
  - .1 During course of Work and [#] weeks prior to project completion, schedule progress meetings monthly.
  - .2 Contractor, Owner, Consultant and Subcontractors involved in Work, are to be in attendance.
  - .3 Notify parties minimum [#] days prior to meetings.
  - .4 Record minutes of meetings and circulate to attending parties and affected parties not in attendance within [#] days after meeting.
  - .5 Agenda to include the following:
    - .1 Review, approval of minutes of previous meeting.
    - .2 Review of Work progress since previous meeting.
    - .3 Field observations, problems, conflicts.

- .4 Problems which impede construction schedule.
- .5 Review of off-Site fabrication delivery schedules.
- .6 Corrective measures and procedures to regain projected schedule.
- .7 Revision to construction schedule.
- .8 Progress schedule, during succeeding Work period.
- .9 Review submittal schedules: expedite as required.
- .10 Maintenance of quality standards.
- .11 Review proposed changes for effect on construction schedule and on completion date.
- .12 Other business.

## **1.9 EXISTING SERVICES AND UTILITIES**

- .1 Where Work involves breaking into or connecting to existing services, carry out Work at times directed by governing authorities, with minimum of disturbance to pedestrian and vehicular traffic.
- .2 Before commencing Work, establish location and extent of service lines in area of Work and notify Owner or Consultant of findings.
- .3 Submit schedule to and obtain approval from Owner or Consultant for any shut-down or closure of active service or facility. Adhere to approved schedule and provide notice to affected parties.
- .4 Schedule Work to minimize interruptions to existing services and maintain existing services during construction.
- .5 Notify Owner or Consultant forty-eight (48) hours minimum in advance of any interruption in service. Owner to be onsite during connection to Owner infrastructure.
- .6 Where unknown services are encountered, immediately advise Owner or Consultant and confirm findings in writing.
- .7 Known subsurface services and utilities may be indicated on the drawings or otherwise identified. Prior to carrying out any subsurface excavation, contact applicable utilities and Owner or Consultant to precisely locate buried structures or utilities on the ground. All costs to locate and identify such buried services shall be deemed to be included in the Contract Price. Carefully excavate or hydrovac to locate such services and utilities.
- .8 Size, depth and location of existing utilities and structures as indicated are for guidance only. Completeness and accuracy are not guaranteed.
- .9 Do not operate hydrants, valves, electrical, telephone or their controls on existing utility systems. Should it become necessary to operate such a control or make connection to such a system, do so only on the direct instruction of a representative of the Utility or Owner concerned and shall carry out such Work in accordance with the specific instructions of the said representative. When the construction Work passes under and/or in close proximity to underground utility cables or utility poles, include in the unit price the cost for having a

representative of the utility company present during the Work.

- .10 When instructed by the Owner or Consultant, provide a letter from the owners of utilities, stating that all services damaged during construction of the Works have been repaired.
- .11 Arrange with appropriate authority for relocation of buried services that interfere with execution of Work: pay costs of relocating services.
- .12 Maintain and protect from damage, water, sewer, gas, electric, telephone and other utilities and structures encountered as indicated.
- .13 Record location of maintained, re-routed and abandoned underground lines.
- .14 Remove obsolete buried services within 2 m of foundations: cap cut-offs.

### **1.10 EXISTING CONDITIONS**

- .1 Examine soil report if available.
- .2 Conduct, with Owner or Consultant, condition survey of existing buildings, trees and other plants, lawns, fencing, service poles, wires, rail tracks, pavement, survey benchmarks and monuments which may be affected by Work.
- .3 Prior to the commencement of the Work, the Owner or Consultant may arrange for photographs to be taken of the Site of the Work and those properties adjacent to the Site of the Work. Be present or have an authorized representative present during the taking of photographs to make any comments on the conditions of the Site. These photographs, together with a written report on the condition of existing roads, trees, etc., as determined by mutual agreement between the Contractor and Owner or Consultant, will be retained by the Owner or Consultant as a record of Site conditions prior to commencement of Work.
- .4 Protect existing buildings and surface features from damage while Work is in progress. In event of damage, immediately make repair as directed by Owner or Consultant.
- .5 Where required for excavation, cut roots or branches as directed by Owner or Consultant.
- .6 Protection of existing road surfaces:
  - .1 Existing road surfaces are to be protected during all construction activities to ensure damage is kept to an absolute minimum and of a minor nature.
  - .2 Any areas receiving gouges, scratches, chips, scraping, indentations or other damage, to an extent that, in the opinion of the Owner, detracts from their appearance or would cause a premature deterioration or failure of the asphalt or base, will require a general seal overlay of the entire block. The Contractor, at no cost to the Owner, shall provide this seal.
  - .3 At the discretion of the Owner, major surface damage may require removal and replacement of the asphalt surface or base.

### **1.11 HISTORICAL OR ARCHAEOLOGICAL ITEMS**

- .1 If at any time during construction, objects of potential historical or archaeological value are uncovered by the Contractor or contractor, all Work shall cease and shall not continue until the Site has been reviewed by the appropriate representatives and the Owner has approved resumption of the Work.

### **1.12 STREET CLEANING**

- .1 The Contractor and their contractors shall take all necessary precautions to prevent the depositing of mud or debris on public or private roadways adjacent to the Work Site, and roadways accessing off-site areas used for disposal of excess materials or retrieval of borrow material.
- .2 Prompt clean-up of such debris is required, otherwise the Owner will direct necessary clean-up with all costs borne by the Contractor.
- .3 If, because of construction operations, travelled roads become dusty, muddy, rough, and in poor condition for the use by the public, the Contractor shall rectify the problem and keep the inconvenience or nuisance to a minimum. If, in the opinion of the Owner, the time over which the nuisance factor continues is excessive, arrangements shall be made for others to restore the road to a satisfactory condition, the cost for which Work shall be borne by the Contractor.

### **1.13 BLASTING**

- .1 Blasting or other use of explosives is not permitted without prior receipt of written instruction by Owner or Consultant.

### **1.14 TRAFFIC SIGNAGE AND CONTROL**

- .1 The Work shall be done in a manner that creates the least interference with traffic, consistent with safe performance of the Work. The Contractor shall install and maintain such barriers, signs, lights and signallers as may be necessary for the safety and convenience of the public and Work area. Stop signs shall be erected at all intersections within the Work Site and at access points from municipal streets.
- .2 Supply and install signage to meet minimum TAC requirements. All signage must meet minimum retroreflectivity as established by TAC.
- .3 All barricades and signage on municipal streets, at access points to the Work Site, and within the Work Site shall be in conformance with NBDTI signage requirements and the Manual of Uniform Traffic Control Devices for Canada for temporary conditions.
- .4 The Contractor or their contractor shall supply, in addition to required signage and barricades, the necessary number of flag persons at all times when:
  - .1 There is to be less than two (2) lanes of traffic.
  - .2 Closure of a street or portion of a street to traffic.
  - .3 Upon request by the Kennebecasis Regional Police Force.
  - .4 Heavy equipment is operating on or adjacent to a roadway open to public travel.
- .5 The flag persons shall be supplied with standard six hundred (600) millimetre "Stop/Slow" paddles and reflective clothing. The Contractor and their contractors shall be responsible for ensuring the flag persons have successfully completed a Traffic Signallers course and shall be responsible for the actions of all flag persons. Flagging shall be carried in accordance with the Work Area Traffic Control Manual (WATCM).

### **1.15 TRUCK ROUTES**

- .1 All heavy equipment, including trucks hauling borrowed or excavated material or additional heavy equipment shall proceed to and from the Work Site by taking the shortest route to and from the nearest Town truck route and then the shortest route to and from the origins and destination of the required trip.
- .2 The Truck Routes are those as listed in Schedule G of the Town of Quispamsis Traffic By-law.
- .3 The Owner shall be informed of any streets being used to access the subdivision Work Site that are not part of the designated Town truck routes to ensure that proper weight restrictions are adhered to and damage to the existing streets is minimum.
- .4 The Contractor and their contractors shall adhere to Spring Weight Restrictions that shall be enforced by the Owner in accordance with such sections in the Town of Quispamsis Traffic By-law. The Owner reserves the right to periodically and randomly spot check truck weighs by use of the New Brunswick Department of Public Safety Commercial Vehicle Enforcement.
- .5 Trucks shall be clean of excess material and debris prior to hauling material on designated Truck Routes or alternated routes to and from the Work Site. The Owner may enforce covering of materials during the transporting of the materials to and from the Work Site.

### **1.16 SITE CONTROL AND ACCESS**

- .1 Work of this Contract is located in an area where normal Working hours are:
  - .1 7:00 AM to 9:00 PM, Monday to Saturday inclusive.
  - .2 Work performed outside these hours require approval by the Owner or Consultant. Request approval in writing at least 48 hours in advance.
- .2 From time to time, pre-planned disruptions to process operations for periods of # hours will be permitted to accommodate tie-ins and other Work. A shut down of eight (8) hours or more would require significant coordination with the Owner or Consultant.
- .3 If an office on Site is required, provide at own cost. No interior office space will be given to the Contractor. Contractor is responsible for communication needs, i.e., phone, internet, etc.
- .4 Make adequate provision, at own expense, for accommodation and protection of traffic and pedestrians and the owners and occupiers of adjacent premises in the form of bridgeways, guards and fences. Should the Contractor have to divert traffic over any path which is not a travelled vehicular public way, protect same from damage, and repair damage at no additional cost to the Contract.
- .5 During the Contract Period, maintain access to the Site by the Works as required. Such access shall be by means of existing gravel or unmade roads, or other existing tracks wherever these are public rights-of-way and private rights-of-way. In the absence of suitable or convenient existing public access, arrange for the use of private rights-of-way or other means of access in accordance with the Contract wherever required.
- .6 Maintain access to and within the Site to permit the execution of the Work as well as access for other persons and traffic that are entitled to such access.

- .7 Supply and install temporary granular materials or rock as necessary to maintain Site access and facilitate construction. Finished gravels or geotextile damaged or contaminated during the execution of the Work will not be accepted.
- .8 Wherever access over a public right-of-way must necessarily be denied because of the Work of the Contract, obtain, provide and maintain suitable detours and provide sign posts; all with the approval and to the requirements of the authorities having jurisdiction therein.
- .9 Contractor vehicles to be clearly marked with door signs and roof top safety lights.

#### **1.17 TESTING AND SAMPLING**

- .1 Pay for the services of testing laboratory including:
  - .1 Inspection and testing required by laws, ordinances, rules and regulations.
  - .2 Tests specified to be performed by Contractor.
  - .3 Inspection and testing performed exclusively for convenience of Contractor.
  - .4 Testing, adjustment and balancing of process, mechanical and electrical equipment systems.
  - .5 Testing to ensure a safe Work environment for employees or subcontractors employed by the Contractor.
- .2 Provide such assistance, labour and materials as are normally required for examining, measuring and testing the quality, weight or quantity and pay all costs of any material used, and supply samples of materials before incorporation in the Works for testing as may be selected and as specified.
- .3 Perform or arrange for the performance of all tests on all equipment in complete accordance with the relevant clauses of these Specifications and in the presence of the Owner or Consultant.
- .4 The cost of providing assistance, samples, etc., for testing and arranging tests shall be deemed to be covered by and included in the Contract Price unless noted otherwise, elsewhere in these Specifications.
- .5 The Contractor shall have no claim against the Owner or the Consultant in respect of any financial loss which may be suffered from the rejection of any materials or equipment due to their failure to meet specified test requirements, and the Contractor shall also bear the cost of remedying any defects such that the material or equipment will meet the specified tests, or failing this, of removing the material or equipment from the Site. The decision to repair or replace materials and equipment which have failed to meet test requirements will be made by the Owner or Consultant.
- .6 After award of the Contract, submit samples of the sizes and quantities as required by the Specifications, to the Owner or Consultant for review. Do not deliver materials to the Site for use until samples are approved in writing by the Owner or Consultant. Provide such samples without charge.
- .7 During the continuance of the Contract, provide necessary labour and tools to assist the Owner or Consultant in measuring, checking, testing and examining the Work and for the setting out and measurement of the Works, the cost of all such being deemed to be covered by and included in the Contract Price.

## **1.18 QUALITY CONTROL**

- .1 Materials and Workmanship:
  - .1 All equipment, materials and Workmanship shall be the best of the respective kinds described in the Contract and in accordance with the Owner or Consultant instructions and shall be subjected from time to time to such standard tests as the Owner or Consultant may direct at the place of manufacture or fabrication or on the Site.
  - .2 Before ordering materials for incorporation into the Works inform the Owner or Consultant of the source of the materials, except as regards trifling and unimportant matters, no order for such materials shall be given except with the authorization of the Owner or Consultant. Notwithstanding the fact that such authorization may have been given, the Owner or Consultant may forbid the use of any such materials, if upon delivery, they are found to be defective or unsuitable for incorporation in the Works. The Contractor shall keep the Owner or Consultant fully advised of the orders and delivery dates of materials.
  - .3 All material and equipment required to be incorporated into the Work shall be new and unused. Any material found during the progress of the Work to have cracks, flaws, or other defects will be rejected by the Owner or Consultant.
  - .4 Replace materials and equipment found defective in manufacturer or damaged in handling after delivery by the manufacturer. This shall include the furnishing of all materials and labour required for the replacement of installed material and equipment discovered defective prior to the final acceptance of the Work.
- .2 Qualification:
  - .1 Provide proof of qualifications when requested by Owner or Consultant.

## **1.19 NOISE AND VIBRATION**

- .1 Operate Construction Equipment such that there is a minimum amount of noise and vibration. Should excessive noise and vibration be caused, at own expense, rectify the same to the approval of the Owner or Consultant.

## **1.20 BARRICADES**

- .1 Protect persons from injury and avoid property damage by providing barricades, construction signs, torches, flushers, and guards as required during the progress of the construction Work. All material piles, equipment, plant or Construction Equipment which may serve as obstructions shall be enclosed by fences or barricades and shall be protected by proper lights when the visibility is poor.

## **1.21 DAMAGE AND INJURY**

- .1 Bear costs of repairing damage to the Site, property of others and injuries of persons resulting from the Contractor's operation under the Contract.
- .2 Immediately inform the Owner or Consultant of damage or injury to persons, property, services or materials.

- .3 Relocate, under the direction of a qualified provincial land surveyor, survey markers, monuments, and pins moved during the construction of the Works. Costs to be borne by Contractor unless accommodated for in design.

#### **1.22 TEMPORARY SERVICES**

- .1 Provide water, lighting, and power for construction. Connect to the service with a back flow preventer.
- .2 Arrange and pay for temporary heat used during construction and during equipment storage, including cost of installation, fuel, operation, maintenance and removal of equipment.
- .3 Maintain temperatures of minimum 10°C and to the extent necessary to prevent condensation-forming conditions in areas where construction is in progress and in areas where materials and equipment are stored, unless indicated otherwise.
- .4 Ventilate heated areas and keep building free of exhaust or combustion gases.
- .5 Provide and maintain, so long as any Workers are employed on the Works, adequate sanitary conveniences for their use. Provide, maintain and remove sanitary conveniences in accordance with the requirements of all pertinent health regulations and to the approval of the Owner or Consultant.

#### **1.23 WEATHER CONDITIONS**

- .1 Do not perform Work when the weather is unsuitable. Do not place concrete, paving, or paint during freezing weather or upon frozen material unless approved in writing by the Owner or Consultant. When Work is performed during freezing weather, provide necessary means for heating and all materials required in the Work shall be heated. Do not use frozen materials for backfilling and embankment. If there is delay or interruption in the Work due to weather conditions, the necessary precautions shall be taken to bond new Work to old.
- .1 Asphalt and concrete work not to be placed when either the ground is it to be placed on or air temperature is below 6°C.
- .2 Concrete not to be placed on running nor pooling water.
- .3 Asphalt not to be placed on pooling water.
- .4 Seal asphalt to be placed in dry weather only.

#### **1.24 DELIVERY, STORAGE AND HANDLING**

- .1 All materials furnished by or to the Contractor shall be delivered and distributed at the Site by the Contractor and shall be loaded and unloaded so as to avoid shock or damage or dropping. If, however, any material is damaged, the repair or replacement shall be made by the Contractor in a manner approved by the Owner or Consultant, at no additional cost to the Contract.
- .2 Adequately store materials and equipment intended for the Work, until it has been incorporated in the completed project. Store materials and equipment in accordance with the manufacturer's recommendations. Keep interior of pipe, fittings, and other accessories

free from dirt and foreign matter at all times.

- .3 Comply with hauling and disposal regulations of authority having jurisdiction.

## **1.25 CONSTRUCTION WASTE MANAGEMENT AND DISPOSAL**

- .1 Keep Work, property, road surfaces, etc. in vicinity of the Site and in areas where Contractor's trucks will travel, in a clean and orderly condition, free from dirt, dust, snow, ice, rubbish, etc. at all times during the progress of the Work.
- .2 Maintain trucks so that no spillage will occur. Before leaving the Site, trim loads and free wheels of accumulations of soil.
- .3 Keep Site free from accumulations of waste material and rubbish to prevent an unsightly or hazardous condition. On the completion of the Works clear away and remove from the Site all Construction Equipment, surplus materials, rubbish and temporary Works of every kind and leave the whole of the Site and Works clean in a condition that meets the approval of the Owner or Consultant.
- .4 Do not dispose of volatile fluid wastes (such as mineral spirits, oil, or paint thinner) in storm or sanitary sewer systems or into streams or waterways. Owner to identify material that can be salvaged, such as pipe, and Contractor to deliver salvageable materials to Town of Quispamsis Works Department at 18 Municipal Drive.
- .5 Dispose of debris and waste materials in accordance with the latest regulations respecting Solid Waste Resource Management issued by New Brunswick Department of Environment and Local Government, at no additional cost to the Contract.
- .6 Dispose of all construction and demolition waste at an approved C&D waste disposal Site.
- .7 Where possible, divert construction and demolition waste to the appropriate recycling facilities. Minimize waste generated by the Work.
- .8 Store volatile waste in covered metal containers, and remove from premises at end of each Working day.
- .9 Burying rubbish and waste materials on Site is not permitted unless approved in writing by Owner or Consultant.
- .10 Excess excavated material:
- .1 Unless a disposal Site is designated, all excess materials found upon or excavated from the Work Site shall become the property of the Contractor and shall be disposed of in accordance with all Federal, Provincial and Municipal regulations, including the acquisition of permits and disposal approvals. The excess material shall be considered in the custody and the sole responsibility of Contractor and their contractor until disposal at the designated Site, including hauling of the material.
- .2 When sufficient space is not available to allow placing of excavated material within the boundary of Work Site, such excavated material shall be hauled and stockpiled at an off-Site location arranged for by the Contractor. When all excavation is complete, the Contractor or their contractor shall retrieve as much acceptable material as required from the disposal Site to properly refill all excavations or trenches or general backfilling purposes.
- .3 Disposal of excess material, whether temporary or permanent, on any Municipal property or right-of-way without written approval is strictly prohibited, and the

Contractor shall be responsible for the removal and clean-up of such material immediately at no cost to the Owner.

#### **1.26 APPROVED EQUIVALENTS**

- .1 Where any particular brand of manufactured article is described or specified, it is to be regarded as a standard, but another brand equally as good may be accepted, at the discretion of the Owner or Consultant. No change in the Specification will be made prior to the acceptance of the tenders. If the Contractor wishes to make a substitution after the Contract has been awarded, make application, in writing, otherwise the Contractor will be held to the terms of the Specifications. No extra cost will be allowed for approved equivalents.
- .2 When the Owner is prepared to permit the use of a brand of manufactured article as an alternative to any specified brand of manufactured article even though such alternative may not be equivalent to that specified, it may be used at the discretion of the Owner or Consultant but only after price adjustments have been negotiated and approved by the Owner or Consultant.
- .3 If the alternative requires modifications, adjustments or additions to the specified Works, submit to the Owner or Consultant, drawings and specifications for these modifications, adjustments or additions in the same detail as presented in the Contract. Approval in principle by the Owner or Consultant of these modifications, adjustments or additions in no way relieves the Contractor of obligations or liabilities under the Contract to provide for finished piece of Work complete and operational in all essentials.
- .4 No change or substitution can be made without the written consent of the Owner or Consultant.
- .5 The Owner or Consultant will record the time required to evaluate equivalents and alternates proposed by the Contractor including making changes to the Contract Documents occasioned thereby. Whether or not the Owner or Consultant accepts a proposed substitute, reimburse the Owner for the charges of the Consultant for evaluating any proposed substitute.

#### **1.27 DEMONSTRATION AND TRAINING**

- .1 Demonstrate scheduled operation and maintenance of equipment and systems to Owner.
- .2 Owner will provide list of personnel to receive instructions, and will coordinate their attendance at agreed-upon times.
- .3 When specified in individual sections, require manufacturer to provide authorized representative to demonstrate operation of equipment and systems, instruct Owner, and provide written report that demonstration and instructions have been completed.
- .4 Provide copies of completed operation and maintenance manuals for use in demonstrations and instructions.
- .5 Demonstrate start-up, operation, control, adjustment, troubleshooting, servicing, and maintenance of each item of equipment at agreed upon times.
- .6 Instruct personnel in all phases of operation and maintenance using operation and maintenance manuals as the basis of instruction.

- .7 Review contents of manual in detail to explain all aspects of operation and maintenance.
- .8 Prepare and insert additional data in operations and maintenance manuals when the need for additional data becomes apparent during instructions.

### **1.28 GUARANTEE**

- .1 The Contract requires an operational combination of several components comprising the Works which are customarily guaranteed by their suppliers. Under this Contract, however, the Contractor shall provide a guarantee for the Works for a period of one (1) year following the date of Substantial Performance. Owner-supplied equipment and equipment moved/reinstalled from existing locations shall not be included in the operations guarantee. The terms of the Guarantee shall be as follows:
  - .2 Where failure or incipient failure of the material is apparent, the Contractor shall actively commence repair or other remedy not more than twenty-four (24) hours after receiving due notice of trouble.
  - .3 If the Contractor, on being notified, does not for any reason commence repairs within twenty-four (24) hours, the Owner shall have the right to have repairs made by others as necessary to restore or continue service. The cost of such repairs by others shall be borne by the Contractor. The Owner shall at all times inform or attempt to inform the Contractor before hiring others to affect any repairs. It shall, at all times, be the Contractor's right to be informed as soon as possible of difficulties and proposed remedial action by others, to make or where practical to complete such repairs at any other time of the guarantee period in preference to others.
  - .4 The employment of some other person or persons for reasons set out shall in no way affect the Contractor's obligation or liability hereunder or relieve the Contractor of the performance and fulfilment of any or all covenants, undertakings, obligations, or duties under the Contract.
  - .5 After the acceptance by the Owner or Consultant and during the guarantee period, the burden of maintenance shall fall upon the Owner. In the event of damage, failure or incipient failure of any part or parts directly attributable to inadequate or improper maintenance, the Contractor shall be responsible for remedial action but the cost of all such repairs will be reimbursed by the Owner.
  - .6 If the Contractor arranges that the manufacturer of some component, or some other party approved by the Owner or Consultant, provide the guarantee as his agent under the Contract, then due notice to the Agent will be taken as due notice to the Contractor. This will be a matter for Contractor's convenience only, and shall in no way affect the Contractor's obligations and liabilities hereunder or relieve the Contractor from the performance and fulfilment of any or all of his covenants, undertakings, or duties under this Contract.

### **1.29 PROJECT CLOSEOUT REQUIREMENTS**

- .1 Collect reviewed submittals and assemble documents executed by Subcontractors, suppliers, and manufacturers.
- .2 Submit material prior to final Application for Payment.

- .3 Provide warranties fully executed and notarized.
- .4 Execute transition of Performance, and Labour and Materials Payment Bond to warranty period requirements.
- .5 Submit a final statement of accounting giving total adjusted Contract Price, previous payments, and monies remaining due.
- .6 Owner or Consultant will issue a final Change Order reflecting approved adjustments to Contract Price not previously made.
- .7 Record Drawings:
  - .1 After award of Contract, Owner or Consultant will provide two (2) sets of drawings for purpose of maintaining record drawings. Accurately and neatly record deviations from Contract Documents caused by Site conditions and changes ordered by Owner or Consultant.
  - .2 Identify drawings as "Project Record Copy". Maintain in new condition and make available for inspection on Site by Owner or Consultant.
  - .3 On completion of Work and prior to final inspection, submit record documents to Owner or Consultant.
  - .4 Contractor shall maintain as-built record drawings on Site as the Work progresses for all aspects of the Work.
  - .5 Owner will mark on "Project Record Copy" modifications made for Work under the Owner's Scope of Work.

### 1.30 CLEANING

- .1 Leave Work Site clean at end of each day.
- .2 Work Site clean-up:
  - .1 It is the Contractor's sole responsibility to be knowledgeable of and comply with all Federal, Provincial and Municipal regulations regarding the removal and disposal of all rubbish, trash and excess material from the Work Site. Rubbish, trash and unsalvageable excess material shall be disposed of in the approved Fundy Solid Waste Commission Landfill at Crane Mountain.
  - .2 The Owner reserves the right to clean-up the Work Site at cost should the Contractor or their contractors fail to complete clean-up operations within an acceptable timeframe as deemed by the Owner.
  - .3 Without limiting any foregoing regulations, the Owner does not permit:
    - .1 The disposal of waste materials and rubbish by burning, burial on-Site or on any publicly vested property, dumping into watercourses or storm drainage systems.
    - .2 The disposal of volatile wastes such as mineral spirits, oil, gas, or paint thinner into storm or sanitary sewer drains.
  - .4 Progress cleaning: clean and leave Work area clean at end of each day.
  - .5 Final cleaning to be approved by Owner. Upon completion of the Work, remove

surplus materials, rubbish, tools, and equipment.

**2 PRODUCTS – NOT USED.**

**3 EXECUTION – NOT USED.**

**END OF SECTION**

## **1 GENERAL**

### **1.1 REFERENCE STANDARDS**

- .1 Canada Labour Code, Part 2, Canada Occupational Safety and Health Regulations, SOR/86-304.
- .2 Occupational Health and Safety Act, S.N.B, 1983, C 00.2.
- .3 Town of Quispamsis Safety Manual, [date].

### **1.2 SUBMITTALS**

- .1 Submit in accordance with Section 01 00 00 – Project Specific General Requirements.
- .2 Submit copies of reports or directions issued by Federal, Provincial and Territorial health and safety inspectors.
- .3 Submit copies of incident and accident reports.
- .4 Submit WHMIS Safety Data Sheets (SDS) in accordance with Section 01 00 00 – Project Specific General Requirements.

### **1.3 SAFETY ASSESSMENT**

- .1 Perform Site specific safety hazard assessment related to project.

### **1.4 GENERAL SAFETY**

- .1 Observe construction safety measures of Provincial Government, including but not limited to the Occupational Health and Safety Act, WorkSafe NB and Municipal authority provided that in any case of conflict or discrepancy the more stringent requirement shall apply.
- .2 Confirm pollution and environmental control of construction activities are exercised as specified and as required during the Work.

### **1.5 HAZARDOUS MATERIALS**

- .1 Should material resembling hazardous materials other than those identified within the Contract Documents, including, but not limited to, spray or trowel applied asbestos, be encountered in course of work; stop work immediately. Do not proceed until written instructions have been received from Owner or Consultant.
- .2 Where work entails use, storage, or disposal of toxic or hazardous materials, chemicals and or explosives, or otherwise creates a hazard to life, safety, health, or the environment; work shall be in accordance with the Jurisdictional Authority.
- .3 Store volatile waste in closed containers and remove from premises daily.

- .4 WHMIS: Comply with requirements of Workplace Hazardous Materials Information System (WHMIS) regarding use, handling, storage, and disposal of hazardous materials; and regarding labelling and provision of material safety data sheets acceptable to Labour Canada and Health and Welfare Canada.
- .5 Contractor to have WHMIS 2015 training.

## 1.6 CONFINED SPACES

- .1 Carry out Work in confined spaces in compliance with the Provincial Occupational Health and Safety Act (OH&S), - Occupational Safety General Regulations, Part 12 - Confined Space Entry.
- .2 Provide approved air monitoring equipment where workers are working in confined spaces and ensure any test equipment to be used is calibrated, in good working order and used by trained persons.
- .3 Develop a confined space entry program specific to the nature of Work performed and in accordance with OH&S Act and Regulations and confirm supervisors and workers are trained in the confined space entry program.
- .4 Confirm that personal protective equipment and emergency rescue equipment appropriate to the nature of the Work being performed is provided and used.
- .5 Provide and maintain training of workers, as required by the Federal and Provincial Legislation.
- .6 Provide Owner or Consultant with a copy of an "Entry Permit" for each entry into the confined space to ensure compliance with Federal and Provincial Legislation.

## 1.7 FIRE SAFETY

- .1 Comply with and enforce compliance by all personnel all requirements of this specification section, and with all requirements of the latest adopted edition in the province of New Brunswick of the National Building Code of Canada (NBC), National Fire Code of Canada (NFC), including all subsequent revisions, issued by the National Research Council of Canada.
- .2 The Owner or Consultant reserve the right to require dismissal from the Site persons deemed careless or otherwise in violation of the Fire Safety Requirements.
- .3 Comply with all fire safety instructions. Post any applicable safety bulletins or literature in the Site trailer.
- .4 Co-operate with the local Fire Department personnel during Site reviews.
- .5 Confirm all personnel are aware of the location of the nearest fire alarm box and telephone.
- .6 Immediately report all fire incidents as follows:
  - .1 Activate nearest fire alarm box.
  - .2 Telephone 911 Emergency Response.
  - .3 Person activating fire alarm box must remain at the main Site entrance to direct Fire

Department to scene of fire.

- .4 When reporting a fire by telephone, provide location of fire, name or number of building and verify the location.
- .7 Existing fire protection and alarm systems must not be:
  - .1 Obstructed.
  - .2 Shut off.
  - .3 Left inactive at the end of a working day or shift without notification and written authorization from Owner.
  - .4 In addition to above, notify Owner's Facilities Management at least 48 hours prior if scheduling any unavoidable disruption to Fire Protection and Alarm Systems.
- .8 Do not commence with such work until approval and direction are received from the Owner or Consultant.
- .9 Provide and maintain fire extinguishers, necessary to protect the Work.

#### **1.8 FIRST AID**

- .1 During the progress of the Work, provide and maintain at all times and in easily accessible positions on the Works adequate first aid kits equal to those required by WorkSafe NB for the free use as necessary of all persons on Site.

#### **1.9 MEETINGS**

- .1 Schedule and administer Health and Safety meeting with Owner or Consultant prior to commencement of Work.

#### **1.10 RESPONSIBILITY**

- .1 Be responsible for health and safety of persons on Site, safety of property on Site and for protection of persons adjacent to Site and environment to extent that they may be affected by conduct of Work.
- .2 Comply with and enforce compliance by employees with safety requirements of Contract Documents, applicable federal, provincial, territorial and local statutes, regulations, and ordinances.

#### **1.11 POSTING OF DOCUMENTS**

- .1 Ensure applicable items, articles, notices and orders are posted in conspicuous location on Site in accordance with Acts and Regulations of [Province][Territory] having jurisdiction, and in consultation with Owner or Consultant.

#### **1.12 CORRECTION OF NON-COMPLIANCE**

- .1 Immediately address health and safety non-compliance issues identified by authority having jurisdiction or by Owner or Consultant.
- .2 Provide Owner or Consultant with written report of action taken to correct non-compliance of health and safety issues identified.
- .3 Owner or Consultant may stop Work if non-compliance of health and safety regulations is not corrected.

### **1.13 BLASTING**

- .1 Blasting or other use of explosives is not permitted without prior receipt of written instruction by Owner or Consultant.

### **1.14 POWDER ACTUATED DEVICES**

- .1 Use powder actuated devices only after receipt of written permission from Owner or Consultant.

### **1.15 WORK STOPPAGE**

- .1 Give precedence to safety and health of public and Site personnel and protection of environment over cost and schedule considerations for Work.

### **2 PRODUCTS – NOT USED.**

### **3 EXECUTION – NOT USED.**

**END OF SECTION**

## **1 GENERAL**

### **1.1 DESCRIPTION**

- .1 This Section includes the supply of all materials, labour and equipment necessary for Environmental Protection on all work sites as required and herein specified.
- .2 Assume responsibility for dust prevention on any street or site where works have been or are being carried out. Dust prevention shall be in effect until such works are restored to original condition or upon issuance of the "Certificate of Final Acceptance".
- .3 Dust prevention includes sweeping of paved roadways and/or sidewalks and flushing of same, when deemed necessary by the Owner or Consultant. All methods of dust prevention must be approved by the Owner or Consultant.
- .4 Silt fence and erosion/environmental control structures may be required to remain in place and be maintained under this Contract for up to two (2) years.

### **1.2 DEFINITIONS**

- .1 Environmental Pollution and Damage: presence of chemical, physical, biological elements or agents which adversely affect human health and welfare; unfavourably alter ecological balances of importance to human life; affect other species of importance to humans; or degrade environment aesthetically, culturally and/or historically.
- .2 Environmental Protection: prevention/control of pollution and habitat or environment disruption during construction.

### **1.3 ACTION AND INFORMATIONAL SUBMITTALS**

- .1 Submit in accordance with Section 01 00 00 – Project Specific General Requirements.
- .2 Submit Environmental Protection Plan (EPP) for review [and approval] by Owner or Consultant before delivering materials to Site or commencing construction activities.
- .3 EPP shall include comprehensive overview of known or potential environmental issues to be addressed on Site during construction.
- .4 Address topics at level of detail commensurate with environmental issue and required construction task(s).
- .5 Include in Environmental Protection Plan (EPP):
  - .1 Name(s) of person(s) responsible for ensuring adherence to EPP.
  - .2 Name(s) and qualifications of person(s) responsible for manifesting hazardous waste to be removed from Site.
  - .3 Name(s) and qualifications of person(s) responsible for training Site personnel.
  - .4 Descriptions of environmental protection personnel training program.

- .5 Submit a Site-specific Stormwater Pollution Prevention Plan (SPPP). Include the Site-specific Erosion and Sediment Control Plan (ESCP) identifying the type and location of erosion and sediment control measures to be provided on Site. Include monitoring and reporting requirements to ensure that ESCP control measures are in compliance with erosion and sediment control plan, Federal and Provincial regulations, and Municipal by-laws.
- .6 Submit drawings indicating locations of proposed temporary excavations or embankments for haul roads, stream crossings, material storage areas, structures, sanitary facilities, and stockpiles of excess or spoil materials including methods to control runoff and to contain materials on Site.

#### **1.4 FIRES**

- .1 Fires and burning of rubbish on Site is not permitted.

#### **1.5 DRAINAGE**

- .1 Ensure that the temporary erosion and pollution control features are provided and that its recommendations are followed on Site, in accordance with Site-specific Erosion and Sediment Control Plan, at all times during construction.
- .2 Provide temporary drainage and pumping as required to keep excavations on Site free of standing water.
- .3 Obtain Owner or Consultant approval before pumping standing water, which is free of suspended materials, into waterways, sewer or drainage systems.
- .4 Control disposal or runoff of water containing suspended materials or other harmful substances in accordance with the Site-specific Erosion and Sediment Control Plan in compliance with the requirements of authorities having jurisdiction.

#### **1.6 SITE CLEARING AND PLANT PROTECTION**

- .1 Protect trees and plants on Site and adjacent properties as indicated.
- .2 Protect trees and shrubs adjacent to construction work, storage areas and trucking lanes, and encase with protective wood framework from grade level to height of [two (2)] meters minimum. Ensure that control measures used for protection are in compliance with Municipal laws and regulations.
- .3 Protect roots of designated trees to dripline during excavation and Site grading to prevent disturbance or damage.
- .4 Avoid unnecessary traffic, dumping and storage of materials over root zones.
- .5 Minimize stripping of topsoil and vegetation.
- .6 Restrict tree removal to areas where indicated or as directed by the Owner or Consultant. Obtain permits before trees removal in accordance with the requirements of the authorities having jurisdiction.

## **1.7 WORK ADJACENT TO WATERCOURSES AND WETLANDS**

- .1 All work within 30m of a watercourse or wetland to be done in accordance with NBDELG and a WAWA permit to be obtained by Owner or Consultant prior to start of Work.
- .2 Construction Equipment to be operated on land only.
- .3 Limit the use of waterway beds for borrow material only after written receipt of approval from Owner or Consultant.
- .4 Avoid indicated spawning beds when constructing temporary crossings of waterways.
- .5 Keep waterways free of excavated fill, waste material and debris.
- .6 Design and construct temporary crossings to minimize waterways erosion.
- .7 Do not skid logs or construction materials across waterways.

## **1.8 POLLUTION CONTROL**

- .1 Maintain temporary erosion and pollution control features installed under this Contract in accordance with Site-specific Erosion and Sediment Control Plan.
  - .1 The Contractor and their contractors shall provide for and maintain temporary erosion and pollution control features where indicated on drawings or as directed by Owner or Consultant.
  - .2 The Contractor and their contractors shall provide for and maintain temporary silt fence where indicated on drawings or as directed by Owner or Consultant.
- .2 Control emissions from equipment and plant in accordance with local authorities' emission requirements. Check with local authorities for any environmental compliance requirements.
- .3 Prevent sandblasting and other extraneous materials from contaminating air and waterways beyond application area.
- .4 Supply and install temporary enclosures where indicated or as directed by Owner or Consultant.
- .5 Cover or wet down dry materials and rubbish to prevent blowing dust and debris. Provide dust control for temporary roads.

## **1.9 DUST CONTROL**

- .1 Dust control:
  - .1 The Contractor and their contractors shall provide for and maintain dust control at times wherever:
    - .1 The operation of any equipment necessary to execute the Work of subdivision development causes dust that may cause a nuisance to residents of the area.
    - .2 Bare soil conditions are created in performing work included in, or

pertaining to this project.

- .2 The Owner's decision as to what provisions are required to maintain adequate dust control shall be final. There shall be no compensation for water, sprinkling equipment, or any other dust control measures taken.
- .3 The application of water shall be the primary means of dust control. The water used shall be contaminant-free and obtained from a source approved by the Owner and any other regulatory agency. The Contractor shall be responsible for obtaining the necessary approvals for retrieval of water from a source and the method use.
- .4 Water shall be applied by equipment capable of applying the water at a uniform and evenly distributed rate in amounts as required and/or as directed.
- .5 The use of calcium chloride shall be at the end of each working day or the end of the work week, if deemed necessary and at the approval of the Engineer.

#### 1.10 NOTIFICATION

- .1 Owner or Consultant will notify Contractor in writing of observed noncompliance with Federal, Provincial environmental laws and regulations or Municipal environmental bylaws, permits, and other elements of Site-specific plans, such as EPP, SPPP, TCP, SCP, SWDP, APCP, CPP, WMP, PTP and IPP as applicable.
- .2 Contractor after receipt of such notice, shall inform Owner or Consultant of proposed corrective action and take such action to obtain the approval of Owner or Consultant.
- .3 Take action only after receipt of written approval by Owner or Consultant.
- .4 Owner or Consultant will issue stop order of work until satisfactory corrective action has been taken.
- .5 No time extensions granted or equitable adjustments allowed to Contractor for such suspensions.

#### 1.11 MEASUREMENT FOR PAYMENT

- .1 Measurement for payment Sediment Control Structure (NBDTI Type C) will on a Unit Price basis, for supply and installation.
- .2 Measurement for payment for sediment control fence will be lineal meters (m), for supply and installation.
- .3 Dust control shall be paid by the number of 20 kg bags of Calcium Chloride supplied and placed in the completed and accepted work.

## 2 PRODUCTS

### 2.1 SILT FENCE AND EROSION CONTROL STRUCTURES

- .1 **Sediment control fence**: preassembled silt fence with industrial netting pre-stapled to

posts and intermediate posts:

- .1 Envirofence as manufactured by Mirafi Inc.
- .2 Terrafence as manufactured by Terrafix.
- .3 Approved equivalent.
- .2 **Sediment Control Structure (NBDTI Type C):**
  - .1 Clear stone to Section 31 05 16 – Aggregate Materials.
  - .2 Bales of hay or straw densely compacted and securely tied.
  - .3 Rip rap to Section 31 37 00 – Rip Rap.
  - .4 Fabric shall be sheet of woven plastic yarn.
- .3 **Sediment control pond:**
  - .1 Clear stone to Section 31 05 16 – Aggregate Materials.
  - .2 Bales of hay or straw densely compacted and securely tied.
  - .3 Rip rap to Section 31 37 00 – Rip Rap.
  - .4 Fabric shall be sheet of woven plastic yarn.

## 2.2 DUST CONTROL

- .1 Water:
  - .1 Provide contaminant-free water obtained from a source approved by the regulatory agency. The owner's water is not to be used for this purpose.
- .2 Calcium Chloride: to ASTM D98
  - .1 Loose, dry flakes or pellets: fine enough to feed readily through the common form spreaders used in roadwork.
  - .2 Liquid calcium chloride: 35% calcium chloride.

## 3 EXECUTION

### 3.1 TEMPORARY EROSION AND SEDIMENT CONTROL

- .1 Supply and install temporary erosion and sediment control measures to prevent soil erosion and discharge of soil-bearing water runoff or airborne dust to adjacent properties and walkways, according to requirements of authorities having jurisdiction or sediment and erosion control drawings specific to Site, that comply with authorities having jurisdiction, whichever is more stringent.
- .2 Inspect, repair, and maintain erosion and sedimentation control measures during construction until permanent vegetation has been established.

- .3 Remove accumulated sediment from behind fences and berms regularly and when directed by Owner or Consultant.
- .4 Remove accumulated sediment from within settling pond regularly and as directed by Owner or Consultant.
- .5 Remove erosion and sedimentation controls and restore and stabilize areas disturbed during removal.

**END OF SECTION**

THIS SECTION SHALL BE READ IN CONJUNCTION WITH, AND TAKE PRECEDENCE, WHERE SPECIFICATIONS MAY DIFFER FROM TOWN OF QUISPAMSIS STANDARD SPECIFICATIONS FOR MUNICIPAL SERVICES.

**1 SUPPLEMENTARY CONDITIONS TO THE STANDARD SPECIFICATIONS FOR MUNICIPAL SERVICES**

**1.1**

**.1**

**END OF SECTION**

# PART II

# TECHNICAL SPECIFICATIONS

## **1 GENERAL**

### **1.1 DESCRIPTION**

- .1 This Section specifies the requirements for the supply and production of granular materials including initial backfill, subbase and base as shown on project drawings and according to project specifications.

### **1.2 REFERENCE STANDARDS**

- .1 ASTM D5821-13 (2017), Standard Test Method for Determining the Percentage of Fractured Particles in Coarse Aggregate.

### **1.3 ACTION AND INFORMATIONAL SUBMITTALS**

- .1 Samples:
- .1 Provide aggregate grain size distribution from recent samples of materials that are to be incorporated into the Project. Samples and grain size distribution to be from samples taken within the last 30 days prior to submission.
  - .2 Submit product samples to Owner or Consultant two (2) weeks prior to start of work upon request.
  - .3 Allow continual sampling by Owner or Consultant during production upon request.
  - .4 Provide Owner or Consultant with access to source and processed material for sampling.
  - .5 Install sampling facilities at discharge end of production conveyor, to allow Owner or Consultant to obtain representative samples of items being produced. Stop conveyor belt when requested by Owner or Consultant to permit full cross section sampling.
  - .6 Provide front end loader or other suitable equipment including trained operator for stockpile sampling as necessary. Move samples to storage place as directed by Owner or Consultant.
  - .7 Supply new or clean sample bags or containers according appropriate to aggregate materials.
  - .8 Pay cost of sampling and testing of aggregates which fail to meet specified requirements.

### **1.4 DELIVERY, STORAGE AND HANDLING**

- .1 Handle and transport aggregates to avoid segregation, contamination and degradation.
- .2 Store washed materials or materials excavated from underwater 24 hours minimum to allow free water to drain and for materials to attain uniform water content.

## 2 PRODUCTS

### 2.1 MATERIALS

- .1 Aggregate quality: sound, hard, durable material free from soft, thin, elongated or laminated particles, organic material, clay lumps or minerals, free from adherent coatings and injurious amounts of disintegrated pieces or other deleterious substances.
- .2 Aggregate materials to conform to NBDTI 2023 Standard Specifications Item 201 and physical properties as per table below:

**Aggregate Physical Properties**

Test / Method	Aggregate Type	Value
Micro-Deval (MTO LS-618)	Aggregate Base	Max. 25%
	Aggregate Subbase	Max. 30%
Freeze Thaw (MTO LS-619)	All Aggregates	Max. 20%
Flat & Elongated Particles @ 4:1 (MTO LS-608)	Crushed Rock Aggregates only (quarried rock)	Max. 35%
Crushed Particles (ASTM D5821) (at least 1 fractured face)	Crushed Gravel Base only	Min. 40%
Plasticity Index (AASHTO T89 & T90)	Aggregate Base	Max. 3
	Aggregate Subbase	Max. 5
Total Sulphur / Neutralizing Potential Ratio (NPR)	Crushed Rock Aggregates only (quarried rock)	Max. 0.3% or NPR ≥ 3

- .3 **Crushed Rock Base and Subbase:** produced by the crushing and processing of rock to conform to the grading limits shown in the table below:

**Crushed Rock Grading Limits**

ASTM Sieve Size	Aggregate Base		Aggregate Subbase	
	25 mm % passing	31.5 mm % passing	50 mm % passing	75 mm % passing
90.0 mm				100
75.0 mm				95-100
63.0 mm			100	85-100
50.0 mm			95-100	73 - 95
37.5 mm		100	76-100	58 - 87
31.5 mm	100	95-100		
25.0 mm	95 - 100	81-100	60-84	
19.0 mm	71-100	66-90	50-76	35 - 69
12.5 mm	56-82	50-77		
9.5 mm	47-74	41-70	32-61	25 - 54
4.75 mm	31-59	27-54	21-49	17 - 43
2.36 mm	21-46	17-43	15-40	12 - 35
1.18 mm	13-34	11-32	10-32	8 - 28
300 µm	5-18	4-19	4-18	4 - 16
75 µm	0-8	0-8	0-9	0 - 9

- .4 **Crushed gravel base and subbase:** produced by the crushing and processing of gravel to conform to the grading limits shown in the table below:

**Crushed Gravel Grading Limits**

ASTM Sieve Size	Aggregate Base		Aggregate Subbase	
	25 mm % passing	31.5 mm % passing	50 mm % passing	75 mm % passing
90.0 mm				100
75.0 mm				95-100
63.0 mm			100	86-100
50.0 mm			95-100	75 - 95
37.5 mm		100	79-100	61 - 87
31.5 mm	100	95-100		
25.0 mm	95 - 100	83-100	63-85	
19.0 mm	75-100	70-90	53-78	38-70
12.5 mm	60-82	55-78		
9.5 mm	52-75	45-72	35-62	28-56
4.75 mm	36-61	30-57	24-51	19-46
2.36 mm	25-48	20-46	17-42	13-37
1.18 mm	16-38	14-35	12-33	9-30
300 µm	5-16	5-19	5-18	4 - 16
75 µm	0-6	0 - 6	0-7	0 - 7

- .5 **Pit run gravel:** composed of naturally formed particles of stone that conform to the grading limits in the table below. Oversize rocks in the pit run material shall be removed from the Work.

**Pit Run Gravel Grading Limits**

ASTM Sieve Size	% passing
125.0 mm	100
100.0 mm	95-100
75.0 mm	82-100
50.0 mm	62-100
37.5 mm	52-100
19.0 mm	30-90
9.5 mm	22-79
4.75 mm	16-66
2.36 mm	12-55
1.18 mm	9-44
300 µm	4-25
75 µm	0-7

**Crushed Shoulder Material:** produced by the crushing and processing of rock or gravel to conform to the grading limits below:

**Crushed Shoulder Material Grading Limits**

<b>ASTM Sieve Size</b>	<b>19.0 mm % passing</b>
25.0 mm	100
19.0 mm	80-100
12.5 mm	0
9.5 mm	60-80
4.75 mm	48-65
2.36 mm	35-50
1.18 mm	19-30
300 µm	13-23
75 µm	2-8

**2.2 SOURCE QUALITY CONTROL**

- .1 Inform Owner or Consultant of proposed source of aggregates and provide access for sampling two (2) weeks minimum before starting production.
- .2 If materials from proposed source do not meet, or cannot reasonably be processed to meet, specified requirements, locate alternative source.
- .3 Advise Owner or Consultant two (2) weeks minimum in advance of proposed change of material source.
- .4 Acceptance of material at source does not preclude future rejection if it fails to conform to requirements specified, lacks uniformity, or if its field performance is found to be unsatisfactory.

**3 EXECUTION**

**3.1 PREPARATION**

- .1 Aggregate source preparation:
  - .1 Quarried rock is specified for all subbase, base and shoulder material, however if a submitted alternative of crushed pit run to manufacture the various gravels will be considered.
  - .2 Pit and/or Quarry source must be approved with COA as issued by Province or Municipality.
- .2 Processing:
  - .1 Process aggregate uniformly using methods that prevent contamination, segregation and degradation.
  - .2 Blend aggregates, as required to meet physical requirements of specification to satisfy gradation requirements for material and, percentage of crushed particles, or particle shapes specified.
- .3 When operating in stratified deposits use excavation equipment and methods that produce uniform, homogeneous aggregate gradation.

- .4 Screen, crush, wash, classify and process aggregates with suitable equipment to meet requirements.
- .5 Stockpiling:
  - .1 Stockpile aggregates in sufficient quantities to meet project schedules.
  - .2 Stockpiling sites to be level, well drained, and of adequate bearing capacity and stability to support stockpiled materials and handling equipment.
  - .3 Except where stockpiled on acceptably stabilized areas, provide compacted sand base not less than 300 mm in depth to prevent contamination of aggregate. Stockpile aggregates on ground but do not incorporate bottom 300 mm of pile into Work.
  - .4 Separate different aggregates by strong, full depth bulkheads, or stockpile far enough apart to prevent intermixing.
  - .5 Do not use intermixed or contaminated materials. Remove and dispose of rejected materials as directed by Owner or Consultant within 48 hours of rejection.
  - .6 During winter operations, prevent ice and snow from becoming mixed into stockpile or in material being removed from stockpile.

### **3.2 CLEANING**

- .1 Leave aggregate stockpile Site in tidy, well drained condition, free of standing surface water.
- .2 Leave any unused aggregates in neat compact stockpiles.
- .3 For temporary or permanent abandonment of aggregate source, restore source to condition meeting requirements of authority having jurisdiction.
- .4 Restrict public access to temporary or permanently abandoned stockpiles.

**END OF SECTION**

## **1 GENERAL**

### **1.1 DESCRIPTION**

- .1 This Section specifies requirements for clearing and grubbing of existing trees, brush, and vegetation.

### **1.2 DEFINITIONS**

- .1 Clearing: consists of cutting off trees and brush vegetative growth to not more than 300 mm above ground and disposing of felled trees, previously uprooted trees and stumps, and surface debris.
- .1 Close-cut clearing: consists of cutting off standing trees, brush, scrub, roots, stumps and embedded logs, removing at, or close to, existing grade and disposing of fallen timber and surface debris.
- .2 Clearing isolated trees: consists of cutting off to not more than 300 mm above ground of designated trees and disposing of felled trees and debris.
- .3 Underbrush clearing: consists of removal from treed areas of undergrowth, deadwood, and trees smaller than 50 mm trunk diameter and disposing of fallen timber and surface debris.
- .2 Grubbing: consists of excavation and disposal of stumps and roots, boulders and rock fragments of specified size to not less than 200 mm depth below existing ground surface.
- .3 Erosion: deterioration, displacement, or transportation of land surface by wind or water, intensified by land clearing practices related to construction work.
- .4 Sediment: particulate matter transported and deposited as a layer of solid particles within a body of water.

### **1.3 PROTECTION**

- .1 Prevent damage to fencing, trees, shrubs, landscaping, natural features, benchmarks, existing buildings, existing pavement, utility lines, Site appurtenances, water courses and root systems of trees which are to remain.
- .1 Repair damaged items to approval of Owner or Consultant.
- .2 Replace any damaged trees designated to remain, as directed by Owner or Consultant.

### **1.4 ENVIRONMENTAL REQUIREMENTS**

- .1 Perform clearing and grubbing work in accordance with the Site-specific specifications and as directed by Owner or Consultant.

- .2 Clean up spills of volatile materials immediately with absorbent material and safely discard to appropriate handling facility.
- .3 Do not dispose of unused volatile materials into sewer system, into streams, lakes, onto ground or in other location where they will pose health or environmental hazard.
- .4 Ensure safe use and disposal of volatile material complies with all Federal, Provincial and Municipal regulations, particularly the Canadian Environmental Assessment Act (CEAA) and the Canadian Environmental Protection Act, and the Pest Control Products Act.

## **1.5 MEASUREMENT FOR PAYMENT**

- .1 Clearing and grubbing shall be paid on a square metre (m<sup>2</sup>) basis, including all material, equipment, and labour necessary to complete the Work.

## **2 PRODUCTS – NOT USED.**

## **3 EXECUTION**

### **3.1 EROSION AND SEDIMENT CONTROL**

- .1 Erosion and sediment control measures as indicated in Section 01 35 43 – Project Specific Environmental Procedures.

### **3.2 PREPARATION**

- .1 Inspect Site and verify with Owner or Consultant, any items designated to remain.
- .2 Locate and protect utility lines: preserve in operating condition active utilities traversing Site.
  - .1 Notify utility authority immediately of damage to or when unknown existing utility lines are encountered.
  - .2 When utility lines which are to be removed are encountered within area of operations, notify utility authority in ample time to minimize interruption of service.
- .3 Notify utility authorities before starting clearing and grubbing.
- .4 Keep roads and walks free of dirt and debris.

### **3.3 CLEARING**

- .1 Clearing includes felling, trimming, and cutting of trees into sections and satisfactory disposal of trees and other vegetation designated for removal, including downed timber, snags, brush, and rubbish occurring within cleared areas.
- .2 Clear as directed by Owner or Consultant, by cutting at height of not more than 300 mm

above ground. In areas to be subsequently grubbed, height of stumps left from clearing operations to be not more than 1000 mm above ground surface.

- .3 Cut off branches and cut down trees overhanging area cleared as directed by Owner or Consultant.
- .4 Cut off unsound branches on trees designated to remain as directed by Owner or Consultant.

### **3.4 CLOSE CUT CLEARING**

- .1 Close cut clearing to within 100 mm of ground surface.
- .2 Cut off branches, down trees overhanging area cleared as directed by Owner or Consultant.
- .3 Cut off unsound branches on trees designated to remain as directed by Owner or Consultant.

### **3.5 ISOLATED TREES**

- .1 Cut off isolated trees as directed by Owner or Consultant at height of not more than 300 mm above ground surface.
- .2 Grub out isolated tree stumps.
- .3 Prune individual trees as indicated.
- .4 Trim trees designated to be left standing within cleared areas of dead branches 4 cm or more in diameter; and trim branches to heights as indicated.
- .5 Cut limbs and branches to be trimmed close to bole of tree or main branches.

### **3.6 UNDERBRUSH CLEARING**

- .1 Clear underbrush from areas as indicated to within 100 mm of ground surface.

### **3.7 GRUBBING**

- .1 Remove and dispose of roots larger than 7.5 cm in diameter, matted roots, and designated stumps from indicated grubbing areas.
- .2 Grub out stumps and roots to not less than 200 mm below ground surface.
- .3 Grub out visible rock fragments and boulders, greater than 300 mm in greatest dimension, but less than 0.25 m<sup>3</sup>.
- .4 Fill depressions made by grubbing with suitable material and to make new surface conform with existing adjacent surface of ground.

**3.8 REMOVAL AND DISPOSAL**

- .1 Remove cleared and grubbed materials to disposal area approved by Owner or Consultant.
- .2 All merchantable timber may be salvaged and is the property of the contractor unless otherwise specified.
- .3 Disposal of cleared and grubbed materials by burning and burying is not permitted.
- .4 Spread hay mulch material on disturbed areas not scheduled for immediate restoration.

**3.9 FINISHED SURFACE**

- .1 Leave ground surface in condition suitable for immediate grading operations or stripping of topsoil to approval of Owner or Consultant.

**END OF SECTION**

## 1 GENERAL

### 1.1 DESCRIPTION

- .1 The Work included in this section consists of the excavation and disposal of excavated materials necessary for the installation of water mains, sewer mains, structures, service laterals and all appurtenances as per the Drawings and Specifications. Topsoil and/or any other excavated materials will be stockpiled when and as directed by the Owner or Consultant.

### 1.2 REFERENCE STANDARDS

- .1 ASTM C117, Standard Test Method for Materials Finer than 75-Micrometer (No. 200) Sieve in Mineral Aggregates by Washing
- .2 ASTM C136M-9, Standard Test Method for Sieve Analysis of Fine and Course Aggregates
- .3 ASTM D422-63 (2007)e2, Standard Test Method for Particle-Size Analysis for Soil.
- .4 ASTM D698-00, Standard Test Methods for Laboratory Compaction Characteristics of Soil Using Standard Effort (12,400 ft-lbf/ft<sup>3</sup> (600 kN-m/m<sup>3</sup>)).
- .5 ASTM D4318-17e1, Standard Test Methods for Liquid Limit, Plastic Limit, and Plasticity Index of Soils.
- .6 CAN/CGSB-8.1-88, Sieves, Testing, Woven Wire, Inch Series
- .7 CAN/CGSB-8.2-M88, Sieves, Testing, Woven Wire, Metric.
- .8 CSA-A23.1:19/A23.2:19, Concrete materials and methods of concrete construction/Test methods and standard practices for concrete.
- .9 CSA-A3000-18, Cementitious Materials compendium.

### 1.3 DEFINITIONS

- .1 **Common Excavation:** includes the excavation and disposal of all materials of whatsoever in nature except that included in the classification of Rock Excavation. Common excavation shall include the removal of:
- .1 Frozen earth material.
- .2 Pavement, curb and sidewalk.
- .3 Existing pipes, manholes, valves, hydrants, chambers, wood timbers, steel rails, etc.
- .2 **Rock Excavation:** includes the removal of:
- .1 Materials excavated from solid masses of igneous, sedimentary or metamorphic rock, which prior to removal, was integral with the parent mass.
- .2 Solid material in excess of 1.00 m<sup>3</sup> and which cannot be removed by means of heavy-duty mechanical excavating equipment with 0.95 to 1.15 m<sup>3</sup> bucket.

.3 Large masses of concrete meeting the requirements of (1.3.2.2).

.3 **Topsoil**

.1 Material capable of supporting good vegetative growth and suitable for use in top dressing, landscaping and seeding.

.2 Material reasonably free from subsoil, clay lumps, brush, objectionable weeds, and other litter, and free from cobbles, stumps, roots, and other objectionable material larger than 25 millimeters in any dimension.

.4 **Waste material:** excavated material unsuitable for use in Work or surplus to requirements.

.5 **Borrow material:** material obtained from locations outside area to be graded and required for construction of fill areas or for other portions of Work.

.6 **Unsuitable materials:**

.1 Weak, chemically unstable, and compressible materials.

.2 Frost susceptible materials.

.3 Fine grained soils with plasticity index less than 10 when tested to ASTM D4318, and gradation within limits specified when tested to ASTM D422 and ASTM C136. Sieve sizes to CAN/CGSB-8.1CAN/CGSB-8.2.

.4 Coarse grained soils containing more than 20 % by mass passing 0.075 mm sieve.

.7 **Unshrinkable fill:** very weak mixture of cement, concrete aggregates and water that resists settlement when placed in utility trenches, and capable of being readily excavated

.8 **Embankment:** material derived from excavation and placed above original ground or stripped surface up to subgrade elevation

.9 **Pavement:** means surface and/or bases mixes of asphalt concrete

.10 **Pavement Structure:** means all material placed above the Subgrade which would include Aggregate Subbase, Aggregate Base and Pavement.

.11 **Base:** is the layer of crushed aggregate placed as a distinct layer directly below the Pavement.

.12 **Subbase:** is the layer of crushed aggregate placed as a distinct layer between the Base and the Subgrade.

.13 **Subgrade:** is the layer, whether in cut or fill, immediately below the Pavement Structure.

**1.4 QUALITY ASSURANCE**

.1 Submit design and supporting data at least ten (10) working days prior to beginning Work.

.2 Design and supporting data submitted to bear stamp and signature of Professional Engineer licensed in New Brunswick, Canada.

.3 Keep design and supporting data on Site.

.4 Engage services of qualified Professional Engineer who is licensed in New Brunswick, Canada in which Work is to be carried out to design and inspect cofferdams, shoring, bracing and underpinning required for Work.

- .5 Do not use soil material until written report of soil test results are reviewed by Owner or Consultant.

## 1.5 MEASUREMENT FOR PAYMENT

- .1 All common excavation, disposal of excavated material, sand bedding, stone bedding, backfill and compaction necessary for the installation of water and sewer mains, manholes, catch basins, valve chambers, and all appurtenances shall be incidental to the unit price of the water and sewer main, water and sewer lateral pipe, manhole, valve chamber, catch basin or related appurtenances.
- .1 Placement of aggregates within the limits of the new piping installation will be considered incidental to the Work and will not be measured separately for payment
- .2 Removal and disposal of existing pipes, structures and appurtenances (as directed) will be considered incidental to the excavation and will not be measured separately for payment.
- .2 **Rock Excavation:** measured in cubic metres (m<sup>3</sup>) calculated using the average end area of rock in trench excavation. Include all costs to break and/or remove solid rock using power operated hydraulic tools.
- .1 Measurement for Rock Excavation will be calculated in accordance with Standard Detail 33.SD03A - Trench Layout and Payment Limits for Rock Excavation.
- .2 Formula for Average End Area = ([Average Depth of Rock] x [O.D.+ 600 mm]) – ([Average Depth of Rock] x [O.D.+ 300 mm]) = (300 mm x [Average Depth of Rock]).
- .3 Measure excavated boulders and rock fragments individually.
- .3 **Topsoil Stripping:** (Where indicated on the drawings) will be measured in square metres (m<sup>2</sup>) of topsoil stripped to a depth of 200 mm and including stockpiling in an area designated.
- .4 **Extra Excavation/Undercuts:** Measurement for payment for extra excavation and supply and placement of aggregate required due to soft subgrade conditions that existed at the start of construction, shall be in cubic metres (m<sup>3</sup>) for excavation and tonnes as taken from weight slips for supply and placement of aggregates
- .5 **Borrow Material:** Measurement for payment for imported borrow material will be in metric tonnes (t) as taken from the weight slips, or cubic metres (m<sup>3</sup>) in place, including the supply, hauling, placing and compaction.
- .6 **Unshrinkable Fill:** will be measured in cubic metres (m<sup>3</sup>) as taken from the delivery slips, including the supply, hauling, placing and compaction.
- .7 **Geotextile Fabric:** will be measured in square metres (m<sup>2</sup>) of surface covered. The unit rate will include the supply, placement and the preparation of the surface on which it is to be laid.
- .1 Measurement for payment will be the total horizontal or vertical area laid, but will not consider extra fabric used in wrinkles, folds or overlapping the edges.
- .2 Staking of the fabric on steep slopes shall be considered incidental to the Work.
- .8 **Geogrid soil reinforcement:** will be measured in square metres (m<sup>2</sup>) of surface covered by material. The unit rate will include all material, equipment and labour necessary to

acceptably install the material according to the Contract Drawings and Specifications.

- .1 Overlap joints, patches and seams will be measured as a single layer of geotextile or geogrid material, no payment will be made for overlap.
- .9 No separate payment will be made for:
  - .1 The provision of traffic control.
  - .2 Over excavation, beyond the limits and/or grades specified,
  - .3 Compaction and Proof rolling of all roadway areas.
  - .4 Subgrade preparation and compaction.
- .10 Shoring, bracing, cofferdams, underpinning and de-watering of the excavation will be incidental to the work and will not be measured separately.
- .11 Excavation, sawcutting, removal and disposal of asphalt, concrete curb, sidewalk and common material will be considered incidental to the Work and will not be paid for separately.
- .12 Brick and grout of abandoned structures or pipes will be considered incidental to the Work and will not be paid for separately unless otherwise noted.

## 2 PRODUCTS

### 2.1 BEDDING MATERIALS

- .1 **Granular Material:** Crushed rock consisting of clean, hard, durable, angular particles, free from clay lumps, cementation, organic material, frozen material and other deleterious materials.
  - .1 Granular Bedding material used to be in accordance with Section 31 05 16 – Aggregate Materials, and having not more than 10% retained on the 31.5 mm sieve and not more than 10% dust.
- .2 **Screened Stone:** Clean, sound durable crushed rock, crushed gravel or pit-run gravel.
  - .1 Screened Stone Sub-bedding and Bedding used shall conform to the grading limits below:

**Screened Stone Grading Limits**

<b>ASTM Sieve</b>	<b>25.0 mm (%passing)</b>
37.5 mm	100
25.0 mm	35 - 100
12.5 mm	20 - 60
4.75 mm	0

### 2.2 BACKFILL MATERIALS

- .1 Backfill materials require approval of Owner or Consultant.

- .2 Obtain backfill materials from required excavations, indicated borrow areas, or off-site sources.
- .3 Material used for backfilling: Well-graded, capable of being well-compacted, within proper moisture range to optimize compaction, and free of unsuitable or deleterious materials.
- .4 Borrow materials are either granular imported material or suitable (salvaged) excavated material to the approval of the Owner or Consultant. Both are defined below;
  - .1 **On-Site Materials from the Excavation:** Excavated on-site selected material from excavation or other sources.
  - .2 **Granular Borrow:** Imported "Pit Run" or approved equal, conforming to the requirements of Section 31 05 16 – Aggregate Materials.

### 2.3 UNSHRINKABLE FILL

- .1 Unshrinkable fill to have the following qualities to meet the requirements of CSA A23.1 and A23.2, latest editions.
  - .1 Type 10 or Type 30 (High Early Strength for winter construction) General use hydraulic cement shall be 25 kg/m<sup>3</sup>.
  - .2 Maximum compressive strength of 0.40 MPa at 28 days.
  - .3 Slump shall be 150 mm – 200 mm.
  - .4 Air content between 5 % - 8 %
  - .5 Aggregates shall be the type used for concrete, consisting of clean, hard, durable stone or pea gravel free from lumps, soft and flaky particles, organic matter, salt, alkali and adherent coatings. No more than 10 % by weight of the aggregate shall be finer than (passing) the 0.75 mm sieve.
- .2 The mix design for unshrinkable fill shall be reviewed by the Owner or Consultant before placement of any unshrinkable fill.

### 2.4 AGGREGATE BASE AND SUBBASE

- .1 Granular base and subbase: material in accordance with Section 31 05 16 - Aggregate Materials and Section 32 11 23 - Aggregate Placement.

### 2.5 GEOTEXTILE FABRIC

- .1 Use non-woven geotextile fabrics for drainage applications. Use woven geotextile fabric for stabilization and separation under granular roadbase material when specified.
- .2 Geotextile: Type N2 (Terrafix 360R or equal) non-woven synthetic fibre fabric, supplied in rolls.
  - .1 Width: 3.5m minimum
  - .2 Length: 100m minimum
  - .3 Composed of 100% virgin polypropylene staple fibers with U.V. stability of 70%

@500hrs

- .4 Seams: lapped in accordance with manufacturer's recommendations.
- .5 Grab tensile strength and elongation (in any principal direction): ASTM D4632.
- .6 Grab tensile strength: 712N
- .7 Elongation at break: minimum 50%.
- .8 Tear Resistance (ASTM D4533): 267N
- .9 Puncture CBR (ASTM D6241): 1820N.
- .10 Apparent opening size (EOS): to ASTM D4751, 212  $\mu$ m.
- .11 Permittivity: 1.5 sec<sup>-1</sup>
- .3 Geotextile: Type W1 (Terratrack 400W or equal) woven synthetic fibre fabric, supplied in rolls.
  - .1 Width: 3.5m minimum
  - .2 Length: 120m minimum
  - .3 Composed of polypropylene filaments with U.V. stability of 70% @500hrs
  - .4 Seams: lapped in accordance with manufacturer's recommendations.
  - .5 Grab tensile strength and elongation to ASTM D4632.
  - .6 Grab tensile strength of 1417N with grab elongation 15%
  - .7 Tear Resistance (ASTM D4533): 533N
  - .8 Puncture CBR (ASTM D6241): 4450N.
  - .9 Apparent opening size (EOS): to ASTM D4751, Avg. 0.425m.
  - .10 Permittivity: 0.05 sec-1 Avg.

## 2.6 SOIL REINFORCEMENT (STRUCTURAL GEOGRID)

- .1 Soil Reinforcement (Structural Geogrid): (TX140 geogrid by Tensar or equal) triangular formed grid structure, supplied in rolls.
  - .1 Width: 3.0m minimum
  - .2 Length: 75m minimum
  - .3 Rib pitch: 40mm Longitudinal, 40mm Diagonal
  - .4 Mid-rib depth: 1.2mm Diagonal, 1.2mm Transverse
  - .5 Mid-rib width: 1.1mm Diagonal, 1.1mm Transverse
  - .6 Rib shape is rectangular, aperture shape is triangular
  - .7 Radial stiffness at low strain: 225 kN/m @ 0.5% strain
  - .8 Aperture stability: 3.0 kg-cm/deg @ 5.0kg-cm
  - .9 Efficiency at junctions: minimum 93% to GRI GG2

- .10 Seams: installed in accordance with manufacturer's recommendations.
- .11 Chemical resistance: resistant to all natural occurring alkaline and acidic soil conditions.
- .12 Biological resistance: resistant to attack by bacteria and fungi.

### **3 EXECUTION**

#### **3.1 TEMPORARY EROSION AND SEDIMENT CONTROL**

- .1 Supply and install Temporary erosion and sedimentation control as per Section 01 35 43 – Project Specific Environmental Procedures.
- .2 Inspect, repair, and maintain erosion and sedimentation control measures during construction until permanent vegetation has been established.

#### **3.2 PROTECTION**

- .1 Protect existing features that are not part of project removals in accordance with Section 01 00 00 – Project Specific General Requirements.
- .2 Keep excavations clean, free of standing water, and loose soil.
- .3 Where soil is subject to significant volume change due to change in moisture content, cover and protect to Owner or Consultant approval.
- .4 Protect natural and man-made features required to remain undisturbed. Unless otherwise indicated or located in an area to be occupied by new construction, protect existing trees from damage.
- .5 Protect buried services that are required to remain undisturbed.

#### **3.3 SITE PREPARATION**

- .1 Remove obstructions, ice and snow, from surfaces to be excavated within limits indicated.
- .2 Cut pavement or sidewalk neatly along limits of proposed excavation in order that surface may break evenly and cleanly.

#### **3.4 CONSTRUCTION EQUIPMENT**

- .1 Compaction Equipment: Vibratory rollers or vibrating plate compactors capable of obtaining required material densities.
  - .1 Replace or supplement equipment that does not achieve specified densities.
- .2 Water Distributors: Capable of applying water uniformly.

### **3.5 STRIPPING OF TOPSOIL**

- .1 Do not handle topsoil while in wet or frozen condition or in any manner in which soil structure is adversely affected.
- .2 Begin topsoil stripping of areas as indicated after area has been cleared of brush and grasses and removed from Site.
- .3 Strip topsoil to depths as directed by Owner or Consultant.
  - .1 Do not mix topsoil with subsoil.
- .4 Stockpile in locations as directed by Owner or Consultant.
  - .1 Stockpile height not to exceed 2 m and should be protected from erosion.
- .5 Dispose of unused topsoil to location off-site.

### **3.6 STOCKPILING**

- .1 Stockpile fill materials in areas approved by Owner or Consultant.
  - .1 Stockpile granular materials in manner to prevent segregation.
- .2 Protect fill materials from contamination.
- .3 Implement sufficient erosion and sediment control measures to prevent sediment release off construction boundaries and into water bodies.

### **3.7 COFFERDAMS, SHORING, BRACING AND UNDERPINNING**

- .1 Maintain sides and slopes of excavations in safe condition by appropriate methods and in accordance with Health and Safety Act for the Province of New Brunswick.
- .2 Obtain permit from authority having jurisdiction for temporary diversion of watercourse.
- .3 Construct temporary Works to depths, heights and locations as directed by Owner or Consultant.
- .4 During backfill operation:
  - .1 Unless otherwise indicated or directed by Owner or Consultant, remove sheeting and shoring from excavations.
  - .2 Do not remove bracing until backfilling has reached respective levels of such bracing.
  - .3 Pull sheeting in increments that will ensure compacted backfill is maintained at elevation at least 500 mm above toe of sheeting.
  - .4 When sheeting is required to remain in place, cut off tops at elevations as indicated.
- .5 Upon completion of substructure construction:
  - .1 Remove cofferdams, shoring and bracing.
  - .2 Remove excess materials from Site and restore watercourses as directed by Owner or Consultant.

### 3.8 DEWATERING AND HEAVE PREVENTION

- .1 Keep excavations free of water while Work is in progress.
- .2 Provide for Owner or Consultant details of proposed dewatering or heave prevention methods, including dikes, well points, and sheet pile cut-offs.
- .3 Avoid excavation below groundwater table if quick condition or heave is likely to occur.
- .4 Prevent piping or bottom heave of excavations by groundwater lowering, sheet pile cut-offs, or other means.
- .5 Protect open excavations against flooding and damage due to surface run-off.
- .6 Dispose of water in accordance with Section 01 35 43 - Environmental Procedures to approved collection and runoff areas and in manner not detrimental to public and private property.
- .7 Supply, install and maintain temporary drainage ditches and other diversions outside of excavation limits.
- .8 Supply and install flocculation tanks, settling basins, or other treatment facilities to remove suspended solids or other materials before discharging to storm sewers, watercourses or drainage areas.

### 3.9 EXCAVATION

- .1 **General:**
  - .1 Remove concrete, masonry, paving, walks, demolished foundations and rubble and other obstructions encountered during excavation.
  - .2 Excavation must not interfere with bearing capacity of adjacent foundations.
  - .3 Do not disturb soil within branch spread of trees or shrubs that are to remain.
  - .4 If excavating through roots, excavate by hand and cut roots with sharp axe or saw.
  - .5 For trench excavation, unless otherwise authorized by Owner or Consultant in writing, do not excavate more than 30 m of trench in advance of installation operations and do not leave open more than 15 m at end of day's operation.
  - .6 Keep excavated and stockpiled materials safe distance away from edge of trench as directed by Owner or Consultant.
  - .7 Restrict vehicle operations directly adjacent to open trenches.
  - .8 Dispose of surplus and unsuitable excavated material in approved location off-site.
  - .9 Do not obstruct flow of surface drainage or natural watercourses.
  - .10 Earth bottoms of excavations to be undisturbed soil, level, free from loose, soft or organic matter.
  - .11 Notify Owner or Consultant when bottom of excavation is reached.
  - .12 Obtain Owner or Consultant approval of completed excavation.
  - .13 Remove unsuitable material from trench bottom including those that extend below required elevations to extent and depth as directed by Owner or Consultant.

- .14 Correct unauthorized over-excavation as directed by Geotechnical Engineer.
- .15 Hand trim, make firm and remove loose material and debris from excavations:
- .16 Where material at bottom of excavation is disturbed, compact foundation soil to density at least equal to undisturbed soil.

**.2 Trench preparation:**

- .1 Shape bottom of trench as shown on the Standard Detail Drawings to provide a cradle for the pipe on a properly compacted granular bedding,
  - .1 Support evenly for its full length except at joints where additional excavation will be allowed to permit making of the joints.
- .2 Correct any part of the trench excavated below the specified grade with granular fill material and compact in accordance with these specifications.
  - .1 Remove and replace with granular material obstructions such as stones, boulders, etc., along the bottom of the trench and any that occur which could result in unsatisfactory bedding conditions.
- .3 If during the progress of the work, and before installing any piping, the natural soil of the trench bottom becomes soft due to excessive water infiltration, remove and replace the material so impaired and replace with suitable materials acceptable to the Engineer.
- .4 Correct all settlement of pipe, which may be due, in the opinion of the Engineer, to the improper preparation and protection of the trench bottom.
- .5 Remove, rebuild and replace work which may become defective by reason of such neglect, or of failure to properly construct, place and backfill around and over the pipe.

**3.10 FILL TYPES AND COMPACTION**

- .1 Use types of fill as indicated in these specifications. Compaction densities are percentages of maximum densities obtained from ASTM D698 in accordance with Corrected Maximum Dry Density for Fill.
- .2 Exterior side of perimeter walls: use pit run gravel fill to subgrade level. Compact to 95% of corrected maximum dry density.
- .3 Within building area: use pit run gravel to underside of base course for floor slabs. Compact to 100 % of corrected maximum dry density.
- .4 Under concrete slabs: provide 150 mm compacted thickness base course of crushed gravel fill to underside of slab. Compact base course to 100 %.
- .5 Retaining walls: use pit run gravel fill to subgrade level on high side for minimum 500 mm from wall and compact to 95 %. For remaining portion, use pit run gravel fill compacted to 95 %.
- .6 Place unshrinkable fill in areas as indicated.
- .7 If geogrid is used with retaining wall a crushed product would be required to satisfy the requirements of the geogrid manufacturer

### 3.11 BEDDING OF UNDERGROUND SERVICES

- .1 Place granular material for bedding of underground services as indicated in trench details.
- .2 Place bedding material in unfrozen condition.
- .3 Once the trench has been excavated to the required grade, bedding methods and materials must conform to the pipe manufacturer's specifications for all materials being bedded.
- .4 Place bedding under the pipe in maximum 150 mm layers to a minimum depth of 150 mm in common excavation or 300 mm in rock.
- .5 Place bedding in 150 mm layers to a minimum depth of 300 mm over the top of the pipe. The bedding shall be tamped or rodded by hand under the haunches of the pipe. Place and compact succeeding layers to a minimum 95% of the maximum dry density, in accordance with ASTM D698.
- .6 Do not place pipe bedding in water or in trenches having soft or unstable bottom conditions.
- .7 In wet trench conditions only, the Owner or Consultant may approve the use of screened stone, in such case, it shall be completely wrapped in non-woven geotextile filter fabric in order to hinder the migration of fine materials into the rock.
- .8 Compacting equipment for pipe bedding shall be suitably sized so as not to cause damage to the pipe or movement of the pipe due to impact and vibration, and be of ample size to provide the degree of compaction specified.

### 3.12 BACKFILLING

- .1 Do not proceed with backfilling operations until completion of following:
  - .1 Owner or Consultant has inspected and approved installations.
  - .2 Owner or Consultant has inspected and approved of construction below finish grade.
  - .3 Inspection, testing, approval, and recording location of underground utilities.
  - .4 Removal of concrete formwork.
  - .5 Removal of shoring and bracing; backfilling of voids with satisfactory soil material.
- .2 Areas to be backfilled to be free from debris, snow, ice, water and frozen ground.
- .3 Do not use backfill material which is frozen or contains ice, snow or debris.
- .4 Place backfill material in uniform layers not exceeding 300mm compacted thickness up to grades indicated. Compact each layer before placing succeeding layer.
- .5 Backfilling around installations:
  - .1 Place bedding material as specified elsewhere.
  - .2 Do not backfill around or overcast-in-place concrete within 24 hours after placing of concrete.
  - .3 Place layers simultaneously on both sides of installed Work to equalize loading.
- .6 Place unshrinkable fill as backfill material in confined areas under existing pipes or other areas, as shown on the Drawings or as directed by the Owner or Consultant, where the

specified compaction cannot be achieved using conventional backfill materials.

- .1 Consolidate and level unshrinkable fill with internal vibrators.
- .7 Once the pipe bedding material has been placed to the required depth and degree of compaction, the remaining depth of trench shall be backfilled in layers not exceeding 300 mm in thickness (before compaction) and shall be compacted to a minimum 95 % of the maximum dry density, in accordance with ASTM D698.
- .8 Where the excavated material is unsuitable for use as backfill, the Contractor shall dispose of this material and backfill with imported fill material in layers not exceeding 300 mm in thickness (before compaction) and shall be compacted to a minimum 95 % of the maximum dry density, in accordance with ASTM D698.
- .9 Rock fragments larger than 200 mm in greatest dimension shall not be used for trench backfill.
- .10 Compacting equipment used during trench backfill operations shall be suitably sized to provide the specified degree of compaction required. In areas not accessible to compacting equipment a mechanical tamper shall be used.
- .11 The Contractor shall be responsible for quality control (QC) testing for the compaction stage of the work (based on calibrated nuclear density gauge testing) to ensure that density conforms to the requirements of these specifications. Compaction testing on trench backfill material shall be carried out in accordance with the following table:

.1 **Minimum Testing Frequency for Compaction of Soils**

Item No.	Description	Test Method	Testing Frequency	Remarks
1	Trench Work (Water & Sewer)	ASTM D698	Minimum of one Proctor test is required per material type prior to placement. Nuclear density testing done to create a compaction pattern for both bedding and backfill to establish a benchmark to continue until a noticeable change in material. Once procedure is established, Contractor must ensure that the recommended method is followed on all trenches. During pipe trench backfilling, minimum of one (1) nuclear density test per 100m of trench work, for each 300mm lift, or equivalent for shorter trenches.	Nuclear gauge testing. Owner or Consultant to make field notes on method and results.
2	Subgrade Testing (Borrow or Fill Sections)	ASTM D698  Proof Rolling	Minimum of one Proctor test is required per material type prior to placement. One nuclear density field test section per material type - to develop a definite compaction procedure (equipment, lift thickness, moisture application and number of passes), which will produce the required density.	Nuclear gauge testing.

Item No.	Description	Test Method	Testing Frequency	Remarks
			Visual deflection test of all subgrade surfaces with a fully loaded tandem truck.  Minimum one (1) nuclear density test per 20 m of street, for each 300 mm lift.	
3	Subgrade Testing (Cut Sections)	Proof Rolling	Carry out visual deflection test of all subgrade surfaces with a fully loaded tandem truck.	Owner or Consultant to verify in field notes that this was carried out and record the results.
4	Granular Base and Subbase	ASTM D698	Minimum one (1) test per 25 m of street, for each lift of material added.	Nuclear gauge testing.
<p>Note: Frequency or numbers of tests may be increased at any time by the Engineer when deemed necessary or if unfavorable results are recorded.</p>				

- .12 The Contractor shall be responsible for the interpretation of the QC test results and the determination of any action to be taken to ensure that all materials and work conform to the requirements of the Contract.
- .13 Where temporary unbalanced earth pressures are liable to develop on walls or other structures:
  - .1 Permit concrete to cure for minimum 14 days or until it has sufficient strength to withstand earth and compaction pressure and approval obtained from Owner or Consultant. 80% of specified strength of concrete must be achieved prior to backfilling.
  - .2 Place unshrinkable fill in areas as indicated.
  - .3 Consolidate and level unshrinkable fill with internal vibrators.

### 3.13 RESTORATION

- .1 Upon completion of Work, remove waste materials and debris. Trim slopes, and correct defects as directed by Owner or Consultant.
- .2 Replace topsoil as indicated.
- .3 Reinstate lawns to elevation which existed before excavation.

- .4 Reinstatement pavements and sidewalks disturbed by excavation to thickness, structure and elevation which existed before excavation.
- .5 Clean and reinstatement areas affected by Work as directed by Owner or Consultant.
- .6 Use temporary plating to support traffic loads over unshrinkable fill for initial 24 hours.
- .7 Protect newly graded areas from traffic and erosion and maintain free of trash or debris.

**END OF SECTION**

## 1 GENERAL

### 1.1 DESCRIPTION

- .1 This Section consists of the requirements for roadway excavation, embankment construction, granular material placement, compaction and related work for the construction of roadways, curb, sidewalk or other surfaces as per the Drawings and Specifications.

### 1.2 REFERENCE STANDARDS

- .1 ASTM C117, Standard Test Method for Materials Finer than 75-Micrometer (No. 200) Sieve in Mineral Aggregates by Washing
- .2 ASTM C136M-9, Standard Test Method for Sieve Analysis of Fine and Course Aggregates
- .3 ASTM D422-63 (2007)e2, Standard Test Method for Particle-Size Analysis for Soil.
- .4 ASTM D698-00, Standard Test Methods for Laboratory Compaction Characteristics of Soil Using Standard Effort (12,400 ft-lbf/ft<sup>3</sup> (600 kN-m/m<sup>3</sup>)).
- .5 ASTM D4318-17e1, Standard Test Methods for Liquid Limit, Plastic Limit, and Plasticity Index of Soils.
- .6 CAN/CGSB-8.1-88, Sieves, Testing, Woven Wire, Inch Series
- .7 CAN/CGSB-8.2-M88, Sieves, Testing, Woven Wire, Metric.
- .8 CSA-A23.1:19/A23.2:19, Concrete materials and methods of concrete construction/Test methods and standard practices for concrete.
- .9 CSA-A3000-18, Cementitious Materials compendium.

### 1.3 DEFINITIONS

- .1 **Common Excavation:** includes the excavation and disposal of all materials of whatsoever in nature except that included in the classification of Rock Excavation. Common excavation shall include the removal of:
- .1 Frozen earth material.
- .2 Pavement, curb and sidewalk.
- .3 Existing pipes, manholes, valves, hydrants, chambers, wood timbers, steel rails, etc.
- .2 **Rock Excavation:** includes the removal of:
- .1 Materials excavated from solid masses of igneous, sedimentary or metamorphic rock, which prior to removal, was integral with the parent mass.
- .2 Solid material in excess of 1.00 m<sup>3</sup> and which cannot be removed by means of heavy-duty mechanical excavating equipment with 0.95 to 1.15 m<sup>3</sup> bucket.

- .3 Large masses of concrete meeting the requirements of (1.3.2.2).
- .3 **Topsoil**
- .1 Material capable of supporting good vegetative growth and suitable for use in top dressing, landscaping and seeding.
- .2 Material reasonably free from subsoil, clay lumps, brush, objectionable weeds, and other litter, and free from cobbles, stumps, roots, and other objectionable material larger than 25 millimeters in any dimension.
- .4 **Waste material:** excavated material unsuitable for use in Work or surplus to requirements.
- .5 **Borrow material:** material obtained from locations outside area to be graded and required for construction of fill areas or for other portions of Work.
- .6 **Unsuitable materials:**
- .1 Weak, chemically unstable, and compressible materials.
- .2 Frost susceptible materials.
- .3 Fine grained soils with plasticity index less than 10 when tested to ASTM D4318, and gradation within limits specified when tested to ASTM D422 and ASTM C136. Sieve sizes to CAN/CGSB-8.1CAN/CGSB-8.2.
- .4 Coarse grained soils containing more than 20 % by mass passing 0.075 mm sieve.
- .7 **Unshrinkable fill:** very weak mixture of cement, concrete aggregates and water that resists settlement when placed in utility trenches, and capable of being readily excavated
- .8 **Embankment:** material derived from excavation and placed above original ground or stripped surface up to subgrade elevation
- .9 **Pavement:** means surface and/or bases mixes of asphalt concrete
- .10 **Pavement Structure:** means all material placed above the Subgrade which would include Aggregate Subbase, Aggregate Base and Pavement.
- .11 **Base:** is the layer of crushed aggregate placed as a distinct layer directly below the Pavement.
- .12 **Subbase:** is the layer of crushed aggregate placed as a distinct layer between the Base and the Subgrade.
- .13 **Subgrade:** is the layer, whether in cut or fill, immediately below the Pavement Structure.
- 1.4 QUALITY ASSURANCE**
- .1 Submit design and supporting data at least ten (10) working days prior to beginning Work.
- .2 Design and supporting data submitted to bear stamp and signature of Professional Engineer licensed in New Brunswick, Canada.
- .3 Keep design and supporting data on Site.
- .4 Engage services of qualified Professional Engineer who is licensed in New Brunswick, Canada in which Work is to be carried out to design and inspect cofferdams, shoring, bracing and underpinning required for Work.

- .5 Do not use soil material until written report of soil test results are reviewed by Owner or Consultant.

## 1.5 DELIVERY, STORAGE AND HANDLING

- .1 Deliver, store and handle materials in accordance with Section 31 05 16 - Aggregate Materials.

## 1.6 MEASUREMENT FOR PAYMENT

- .1 **Common excavation:** measured in cubic metres (m<sup>3</sup>) calculated from cross sections taken before and after excavation process. Include all material, equipment and labour costs to acceptably shape and compact the material in accordance with the drawings and specifications.
- .1 Owner or Consultant will take initial cross sections after clearing, grubbing, and stripping is complete, immediately before excavation of material to be incorporated into the Work.
- .2 **Rock Excavation:** measured in cubic metres (m<sup>3</sup>) calculated from cross sections of original rock surface and design grade line for excavation. Include all material, equipment and labour costs to break and/or remove solid rock using power operated hydraulic tools.
- .1 Owner or Consultant will take initial cross sections after clearing, grubbing, and stripping is complete, immediately before excavation of material to be incorporated into the Work.
- .2 Measure excavated boulders and rock fragments individually.
- .3 **Topsoil Stripping:** (Where indicated on the drawings) will be measured in square metres (m<sup>2</sup>) of topsoil stripped to a depth of 200 mm and including stockpiling in an area designated.
- .4 **Extra Excavation/Undercuts:** Measurement for payment for extra excavation and supply and placement of aggregate required due to soft subgrade conditions that existed at the start of construction, shall be in cubic metres (m<sup>3</sup>) for excavation and tonnes as taken from weight slips for supply and placement of aggregates.
- .5 **Borrow Material:** measured in cubic metres (m<sup>3</sup>) calculated from cross sections taken before and after excavation.
- .1 Owner or Consultant will take initial cross sections after clearing, grubbing, and stripping is complete, immediately before excavation of material to be incorporated into the Work.
- .2 Volumes to be calculated by the average end area method, including all labour, materials and equipment necessary to place and compact the material.
- .6 **Unshrinkable Fill:** will be measured in cubic metres (m<sup>3</sup>) as taken from the delivery slips, including the supply, hauling, placing and compaction.
- .7 **Geotextile Fabric:** will be measured in square metres (m<sup>2</sup>) of surface covered. The unit rate will include the supply, placement and the preparation of the surface on which it is to be laid.

- .1 Measurement for payment will be the total horizontal or vertical area laid, but will not consider extra fabric used in wrinkles, folds or overlapping the edges.
- .2 Staking of the fabric on steep slopes shall be considered incidental to the Work.
- .8 **Geogrid soil reinforcement**: will be measured in square metres (m<sup>2</sup>) of surface covered by material. The unit rate will include all material, equipment and labour necessary to acceptably install the material according to the Contract Drawings and Specifications.
  - .1 Overlap joints, patches and seams will be measured as a single layer of geotextile or geogrid material, no payment will be made for overlap.
- .9 Adjustment of roadway structures: see Section 33 05 16 – Precast Concrete Structures.
- .10 No separate payment will be made for:
  - .1 The provision of traffic control.
  - .2 Over excavation, beyond the limits and/or grades specified.
  - .3 Compaction and Proof rolling of all roadway areas.
  - .4 Subgrade preparation and compaction.

## 2 PRODUCTS

### 2.1 BACKFILL MATERIAL

- .1 Embankment materials require approval of Owner or Consultant.
- .2 Obtain Embankment fill materials from required excavations, indicated borrow areas, or off-site sources.
- .3 Material used for embankment: Well-graded, capable of being well-compacted, within proper moisture range to optimize compaction, and free of unsuitable or deleterious materials.
- .4 Borrow materials are either granular imported material or suitable (salvaged) excavated material to the approval of the Engineer. Both are defined below;
  - .1 **On-Site Materials from the Excavation**: Excavated on-site selected material from excavation or other sources.
  - .2 **Granular Borrow**: Imported “Pit Run” or approved equal, conforming to the requirements of Section 31 05 16 – Aggregate Materials.

### 2.2 UNSHRINKABLE FILL

- .1 Unshrinkable fill to have the following qualities to meet the requirements of CSA A23.1 and A23.2, latest editions.
  - .1 Type 10 or Type 30 (High Early Strength for winter construction) General use hydraulic cement shall be 25 kg/m<sup>3</sup>.
  - .2 Maximum compressive strength of 0.40 MPa at 28 days.

- .3 Slump shall be 150 mm – 200 mm.
- .4 Air content between 5 % - 8 %
- .5 Aggregates shall be the type used for concrete, consisting of clean, hard, durable stone or pea gravel free from lumps, soft and flaky particles, organic matter, salt, alkali and adherent coatings. No more than 10 % by weight of the aggregate shall be finer than (passing) the 0.75 mm sieve.
- .2 The mix design for unshrinkable fill shall be reviewed by the Owner or Consultant before placement of any unshrinkable fill.

### **2.3 AGGREGATE BASE AND SUBBASE**

- .1 Granular base and subbase: material in accordance with Section 31 05 16 - Aggregate Materials and Section 32 11 23 – Aggregate Placement.

### **2.4 GEOTEXTILE FABRIC**

- .1 Use non-woven geotextile fabrics for drainage applications. Use woven geotextile fabric for stabilization and separation under granular roadbase material when specified.
- .2 Geotextile: Type N2 (Terrafix 360R or equal) non-woven synthetic fibre fabric, supplied in rolls.
  - .1 Width: 3.5m minimum
  - .2 Length: 100m minimum
  - .3 Composed of 100% virgin polypropylene staple fibers with U.V. stability of 70% @500hrs
  - .4 Seams: lapped in accordance with manufacturer's recommendations.
  - .5 Grab tensile strength and elongation (in any principal direction): ASTM D4632.
  - .6 Grab tensile strength: 712N
  - .7 Elongation at break: minimum 50%.
  - .8 Tear Resistance (ASTM D4533): 267N
  - .9 Puncture CBR (ASTM D6241): 1820N.
  - .10 Apparent opening size (EOS): to ASTM D4751, 212 µm.
  - .11 Permittivity: 1.5 sec<sup>-1</sup>
- .3 Geotextile: Type W1 (Terratrack 400W or equal) woven synthetic fibre fabric, supplied in rolls.
  - .1 Width: 3.5m minimum
  - .2 Length: 120m minimum
  - .3 Composed of polypropylene filaments with U.V. stability of 70% @500hrs
  - .4 Seams: lapped in accordance with manufacturer's recommendations.

- .5 Grab tensile strength and elongation to ASTM D4632.
- .6 Grab tensile strength of 1417N with grab elongation 15%
- .7 Tear Resistance (ASTM D4533): 533N
- .8 Puncture CBR (ASTM D6241): 4450N.
- .9 Apparent opening size (EOS): to ASTM D4751, Avg. 0.425m.
- .10 Permittivity: 0.05 sec-1 Avg.

## **2.5 SOIL REINFORCEMENT (STRUCTURAL GEOGRID)**

- .1 Soil Reinforcement (Structural Geogrid): (TX140 geogrid by Tensar or equal) triangular formed grid structure, supplied in rolls.
  - .1 Width: 3.0m minimum
  - .2 Length: 75m minimum
  - .3 Rib pitch: 40mm Longitudinal, 40mm Diagonal
  - .4 Mid-rib depth: 1.2mm Diagonal, 1.2mm Transverse
  - .5 Mid-rib width: 1.1mm Diagonal, 1.1mm Transverse
  - .6 Rib shape is rectangular, aperture shape is triangular
  - .7 Radial stiffness at low strain: 225 kN/m @ 0.5% strain
  - .8 Aperture stability: 3.0 kg-cm/deg @ 5.0kg-cm
  - .9 Efficiency at junctions: minimum 93% to GRI GG2
  - .10 Seams: installed in accordance with manufacturer's recommendations.
  - .11 Chemical resistance: resistant to all natural occurring alkaline and acidic soil conditions.
  - .12 Biological resistance: resistant to attack by bacteria and fungi.

## **3 EXECUTION**

### **3.1 TEMPORARY EROSION AND SEDIMENT CONTROL**

- .1 Supply and install Temporary erosion and sedimentation control as per Section 01 35 43 – Project Specific Environmental Procedures.
- .2 Inspect, repair, and maintain erosion and sedimentation control measures during construction until permanent vegetation has been established.

### **3.2 PROTECTION**

- .1 Protect existing features not part of project removals in accordance with Section 01 00 00 –

Project Specific General Requirements.

- .2 Keep excavations clean, free of standing water, and loose soil.
- .3 Where soil is subject to significant volume change due to change in moisture content, cover and protect to Owner or Consultant approval.
- .4 Protect natural and man-made features required to remain undisturbed. Unless otherwise indicated or located in an area to be occupied by new construction, protect existing trees from damage.
- .5 Protect buried services that are required to remain undisturbed.

**3.3 SITE PREPARATION**

- .1 Remove obstructions, ice and snow, from surfaces to be excavated within limits indicated.
- .2 Cut pavement or sidewalk neatly along limits of proposed excavation in order that surface may break evenly and cleanly.

**3.4 CONSTRUCTION EQUIPMENT**

- .1 Compaction Equipment: Vibratory rollers or vibrating plate compactors capable of obtaining required material densities.
  - .1 Replace or supplement equipment that does not achieve specified densities.
- .2 Water Distributors: Capable of applying water uniformly.

**3.5 STRIPPING OF TOPSOIL**

- .1 Do not handle topsoil while in wet or frozen condition or in any manner in which soil structure is adversely affected.
- .2 Begin topsoil stripping of areas as indicated after area has been cleared of brush and grasses and removed from Site.
- .3 Strip topsoil to depths as directed by Owner or Consultant.
  - .1 Do not mix topsoil with subsoil.
- .4 Stockpile in locations as directed by Owner or Consultant.
  - .1 Stockpile height not to exceed 2 m and should be protected from erosion.
- .5 Dispose of unused topsoil to location off-site.

**3.6 STOCKPILING**

- .1 Stockpile fill materials in areas approved by Owner or Consultant.
  - .1 Stockpile granular materials in manner to prevent segregation.
- .2 Protect fill materials from contamination.

- .3 Implement sufficient erosion and sediment control measures to prevent sediment release off construction boundaries and into water bodies.

### 3.7 ROADWAY EXCAVATING

#### .1 **General:**

- .1 Advise Engineer sufficiently in advance of excavation operations for initial cross sections to be taken.
- .2 Excavate to lines, grades, elevations and dimensions as indicated on Contract Drawings or as directed by the Owner or Consultant.
- .3 Notify Engineer whenever unsuitable materials are encountered in cut sections and remove unsuitable materials to depth and extent directed.
- .4 Remove materials unsuitable for embankments to lateral limits and depths directed.
- .5 Dispose of waste material.

#### .2 **Drainage:**

- .1 Maintain profiles, crowns and cross slopes to provide good surface drainage.
- .2 Maintain surface drainage during excavation of cuts and construction of embankments. Construct ditches in roadway cuts as soon as possible to provide drainage in the cut to prevent softening of the subgrade.

#### .3 **Rock Excavation:**

- .1 If during excavation, material appearing to conform to classification for rock is encountered, notify Engineer in sufficient time to enable measurements to be made to determine volume of rock.
- .2 Remove rock to 300 mm below sub-grade elevation indicated.
- .3 Provide effective drainage to ditches, leaving no undrained pockets in foundation.

#### .4 **Borrow Excavation:**

- .1 Completely use in Embankments, suitable materials removed from right-of-way excavations before taking material from borrow areas.
  - .2 Obtain Embankment materials, in excess of what is available from cut areas, from designated borrow areas.
- .5 Do not excavate roadway or other areas under wet conditions where water is forming ponds or puddles.
- .6 Do not excavate and expose more than 200 m of subgrade during the excavation process.
- .7 All roadway subgrade must be covered by at least 150 mm of crushed stone during any precipitation events and prior to any expected precipitation at night or weekend.
- .8 Hauling of common excavation over granular base and subgrade will not be permitted.

### **3.8 EMBANKMENTS**

- .1 Construct Embankments to the lines, grades, and cross sections indicated on Drawings.
- .2 Construct Embankments in a manner that the first lift, when shaped, forms the toe of foreslopes. Complete each successive lift to the full width before placing the next lift.
- .3 Construct Embankments using earth from excavated or borrow pits. Strip topsoil and organic or deleterious material from all areas on which embankments are to be constructed.
- .4 Place and compact Embankments in layers having a compacted thickness not greater than 300mm.

### **3.9 FINISHING SUBGRADE**

- .1 Remove soft or other unstable material that will not compact properly and fill resulting depressions with approved material.
- .2 Shape and compact entire subgrade to within 30 mm of design elevations but not uniformly high or low.
- .3 Do scarifying, blading, compacting or other methods of work as necessary to provide thoroughly compacted roadbed shaped to grades and cross sections indicated.
- .4 Finish back and side slopes of common material to neat condition, suitable for topsoil and seeding, true to line and grade:
  - .1 Remove boulders encountered in cut slopes and fill resulting cavities with approved material.
  - .2 Hand finish slopes that cannot be finished satisfactorily by machine.
- .5 Finish back and side slopes of rock material to a neat and safe condition, true to line and grade. For rock slopes greater than 1:1, scale slope by removing loose fragments

### **3.10 UNSHRINKABLE FILL**

Place unshrinkable fill as backfill material in confined areas under existing pipes or other areas, as shown on the Drawings or as directed by the Owner or Consultant, where the specified compaction cannot be achieved using conventional backfill materials.

- .1 Consolidate and level unshrinkable fill with internal vibrators.

### **3.11 GEOTEXTILE FABRIC**

- .1 Geotextile fabric shall not be placed until the Site has been prepared by the Contractor and approved by the Owner or Consultant. Geotextile fabric shall be installed in accordance with manufacturer's recommendations.
- .2 Geotextile shall not be placed on brush, limbs, stumps, ice or other material that may tear or puncture the fabric. Geotextile fabric shall be placed such that the surface is free of stress, folds, wrinkles and creases. Where more than one width of fabric is used, it shall be

joined by sewing or by an overlap of at least 500 mm and all overlap joints shall be securely held in-place.

- .3 Damaged areas shall be repaired by the Contractor, at the Contractor's expense, with a patch of the same fabric extending a minimum of 1 m beyond the damaged area.
- .4 No equipment shall be permitted to travel on uncovered fabric. For roadbed construction, at least 300 mm of fill material shall be kept between equipment and fabric.

### **3.12 SOIL REINFORCEMENT (STRUCTURAL GEOGRID)**

- .1 Geogrid shall not be placed until the Site has been prepared by the Contractor and approved by the Owner or Consultant. Geogrid shall be installed in accordance with manufacturer's recommendations.
- .2 Geogrid shall be oriented such that the roll length runs longitudinally and parallel to the traffic direction. Geogrid shall be tensioned by hand and secured at roll ends to the subgrade surface and the ends shall be secured with approved fasteners as recommended by the manufacturer. Geogrid shall be overlapped as shown on the Drawings, or as recommended by the manufacturer. Geogrid shall be cut to shapes as required by the manufacturer.
- .3 Damaged areas shall be repaired by the Contractor, at the Contractor's expense, with a patch of the same material extending a minimum of 1 m beyond the damaged area, or as required by the manufacturer.
- .4 No equipment shall be permitted to travel on uncovered geogrid. At least 150 mm of fill material shall be kept between the equipment and the geogrid, at all times.

### **3.13 COMPACTION**

- .1 Ensure compaction equipment is capable of obtaining required material densities.
- .2 Compact each granular material to density not less than 95% maximum dry density to ASTM D698.
- .3 Shape and roll alternately to obtain smooth, even and uniformly compacted base.
- .4 Apply water as necessary during compacting to obtain specified density.
- .5 In areas not accessible to rolling equipment, compact to specified density with mechanical tampers approved in writing by Owner or Consultant.
- .6 Correct surface irregularities by loosening and adding or removing material until surface is within specified tolerance.

### **3.14 PROOF ROLLING**

- .1 Complete proof rolling on the finished subgrade surface for the purpose of locating unstable areas. Do not place granular subbase and base course until finished subgrade surface is inspected and approved by Owner or Consultant.
  - .1 Use a fully loaded tandem truck for proof rolling.

- .2 Make sufficient passes of proof rolling equipment to make sure that every point on the surface has been subjected to at least one pass of loaded tire and to determine that no greater than 25 mm of deflection occurs.
- .3 Where proof rolling reveals areas of defective (loose, soft, spongy or composed of unsuitable material) subgrade material, remove and replace the defective material to the depth and extent as directed by the Owner or Consultant.

### 3.15 TESTING

- .1 Testing: Granular materials placed for roadway construction, roadway widening, curb and sidewalk projects to conform to the following compaction requirements:
  - .1 Materials Testing Firm shall be engaged by Contractor to perform all laboratory and field-testing requirements for granular materials.
  - .2 Materials Testing Firm shall be registered in the Province of New Brunswick and be qualified in the Work required.
  - .3 All results from the laboratory and field-testing program shall be submitted to the Owner or Consultant for review and approval once tests are completed.
  - .4 Field-testing of the aggregate materials shall be performed using a calibrated nuclear densometer.
  - .5 At the end of project, Contractor is to submit final report encompassing all laboratory and fields-testing results.
  - .6 As a minimum testing frequency, Contractor’s Materials Testing Firm is to complete compaction testing of aggregates as per following table:

#### .1 Minimum Testing Frequency for Compaction of Soils

Item No.	Description	Test Method	Testing Frequency	Remarks
1	Trench Work (Water & Sewer)	ASTM D698	Minimum of one Proctor test is required per material type prior to placement. Nuclear density testing done to create a compaction pattern for both bedding and backfill to establish a benchmark to continue until a noticeable change in material. Once procedure is established, Contractor must ensure that the recommended method is followed on all trenches. During pipe trench backfilling, minimum of one (1) nuclear density test per 100m of trench work, for each 300mm lift, or equivalent for shorter trenches.	Nuclear gauge testing. Owner or Consultant to make field notes on method and results.

Item No.	Description	Test Method	Testing Frequency	Remarks
2	Subgrade Testing (Borrow or Fill Sections)	ASTM D698  Proof Rolling	Minimum of one Proctor test is required per material type prior to placement. One nuclear density field test section per material type - to develop a definite compaction procedure (equipment, lift thickness, moisture application and number of passes), which will produce the required density.  Visual deflection test of all subgrade surfaces with a fully loaded tandem truck.  Minimum one (1) nuclear density test per 20 m of street, for each 300 mm lift.	Nuclear gauge testing.
3	Subgrade Testing (Cut Sections)	Proof Rolling	Carry out visual deflection test of all subgrade surfaces with a fully loaded tandem truck.	Owner or Consultant to verify in field notes that this was carried out and record the results.
4	Granular Base and Subbase	ASTM D698	Minimum one (1) test per 25 m of street, for each lift of material added.	Nuclear gauge testing.
<p>Note: Frequency or numbers of tests may be increased at any time by the Engineer when deemed necessary or if unfavorable results are recorded.</p>				

- .2 The Contractor shall be responsible for the interpretation of the QC test results and the determination of any action to be taken to ensure that all materials and work conform to the requirements of the Contract.

### 3.16 RESTORATION

- .1 Upon completion of Work, remove waste materials and debris. Trim slopes, and correct defects as directed by Owner or Consultant.
- .2 Replace topsoil as indicated.
- .3 Reinstate lawns to elevation which existed before excavation.
- .4 Reinstate pavements and sidewalks disturbed by excavation to thickness, structure and

elevation which existed before excavation.

- .5 Clean and reinstate areas affected by Work as directed by Owner or Consultant.
- .6 Use temporary plating to support traffic loads over unshrinkable fill for initial 24 hours.

### **3.17 CLEANING**

- .1 Refer to Section 01 00 00 – Project Specific General Requirements.

**END OF SECTION**

## **1 GENERAL**

### **1.1 DESCRIPTION**

- .1 This section specifies the requirements for supplying and placing rip rap as shown on the associated drawings.
- .1 Rip rap for each rock shall have both thickness and breadth greater than or equal to one-third of its length.
  - .2 Rip rap shall consist of clean, hard, sound, durable rock, having a density of not less than 2.65 t/m<sup>3</sup> and angular surfaces such that rocks interlock when placed.
  - .3 Acceptability of the rock will be determined by the Owner or Consultant and/or by laboratory and/or field-testing procedures carried out by qualified personnel.
  - .4 The contractor shall notify the Owner or Consultant, in writing, for approval of the source of supply of the rock materials, ten (10) working days in advance of obtaining material from the proposed source.

### **1.2 MEASUREMENT FOR PAYMENT**

- .1 Measurement for payment for supply and placement of random rip rap material shall be the number of tonnes (t) of material acceptably supplied and placed.
- .2 N2 non-woven geotextile is to be included in the unit price of supplying and placing rip rap.
- .3 Removal of debris, snow, ice and other unsuitable material and shaping the construction area prior to placing random rip rap material will not be measured for payment but shall be considered as incidental to the Work.
- .4 Clearing and grubbing in random rip rap locations will be measured and paid as under Section 31 11 00 - Clearing and Grubbing.

## **2 PRODUCTS**

### **2.1 RANDOM RIP RAP MIXED**

- .1 Random rip rap mixed shall be noted as R# mixed and shall consist of a random rip rap material of the designated size thoroughly mixed with a pit run gravel.
- .2 Finely shattered rock which meets the gradations of pit run gravel may be used as a substitute.
- .3 The random rip rap shall produce a consistent mixed homogenous blended supply of the specified mixture, mixed at the proportion of approximately 20% by weight to the random rip rap material indicated to form a very dense material.

## 2.2 RIP RAP

### .1 Rip Rap Grading Limits:

Mass (kg)	Size (mm)	Finer by Mass (%)							
		R-A (Note 1)	R-5	R-10	R-25	R-50	R-100	R-250	R-500
6000	1600								
4000	1400								
3000	1300								
2000	1100								
1500	1000								100
1000	900								70 - 90
750	820							100	
500	710							70 - 90	40 - 55
300	600						100		
250	570							40 - 55	
200	530						70 - 90		
150	480					100			
100	420					70 - 90	40 - 55		
75	380				100				
50	330				70 - 90	40 - 55			0 - 15
25	260			100	40 - 50			0 - 15	
15	220	100	100	70-90					
10	190		70 - 90	40-55			0 - 15		
5	150		40 - 55			0 - 15			
2.5	120	0			0 - 15				
0.5	70		0 - 15						
Thickness (mm) (Note 2)		300	300		500	600	800	1100	1400
NOTES: 1) Random rip rap for abutment and slope protection 2) Measured perpendicular to the prepared surface									

## 2.3 GEOTEXTILE

.1 Geotextile: Type N2 (Terrafix 360R or equal) non-woven synthetic fibre fabric, supplied in rolls.

.1 Width: 3.5m minimum

.2 Length: 100m minimum

.3 Composed of 100% virgin polypropylene staple fibers with U.V. stability of 70%

@500hrs

- .4 Seams: lapped in accordance with manufacturer's recommendations.
- .5 Grab tensile strength and elongation (in any principal direction): ASTM D4632.
- .6 Grab tensile strength: 712N
- .7 Elongation at break: minimum 50%.
- .8 Tear Resistance (ASTM D4533): 267N
- .9 Puncture CBR (ASTM D6241): 1820N.
- .10 Apparent opening size (EOS): to ASTM D4751, 212  $\mu\text{m}$ .
- .11 Permittivity: 1.5  $\text{sec}^{-1}$

### **3 EXECUTION**

#### **3.1 PLACING**

- .1 Where rip rap is to be placed on slopes, excavate trench at toe of slope to dimensions as indicated.
- .2 Fine grade area to be rip rapped to uniform, even surface. Fill depressions with suitable material and compact to provide firm bed.
- .3 Place geotextile on prepared surface in accordance with Section 31 24 13 – Roadway Construction, Embankments and Compaction and as indicated.
- .4 Avoid puncturing geotextile.
- .5 Vehicular traffic over geotextile not permitted.
- .6 Place rip rap to thickness and details as indicated.
- .7 Place stones in manner approved by Owner or Consultant to secure surface and create a stable mass.
- .8 Place larger stones at bottom of slopes.
- .9 Hand placing:
  - .1 Use larger stones for lower courses and as headers for subsequent courses.
  - .2 Stagger vertical joints and fill voids with rock spalls or cobbles.
  - .3 Finish surface evenly, free of large openings and neat in appearance.

**END OF SECTION**

## 1 GENERAL

### 1.1 SECTION INCLUDES

- .1 This section specifies the requirements for supplying, placing and compacting aggregates including granular base, subbase, shoulder material and driveway restoration as shown on project drawings and according to project specifications.

### 1.2 REFERENCE STANDARDS

- .1 ASTM C117, Standard Test Method for Materials Finer than 75-Micrometer (No. 200) Sieve in Mineral Aggregates by Washing.
- .2 ASTM C136M-9, Standard Test Method for Sieve Analysis of Fine and Course Aggregates.
- .3 ASTM D698-00, Standard Test Methods for Laboratory Compaction Characteristics of Soil Using Standard Effort (12,400 ft-lbf/ft<sup>3</sup> (600 kN-m/m<sup>3</sup>)).
- .4 ASTM D4318-17e1, Standard Test Methods for Liquid Limit, Plastic Limit, and Plasticity Index of Soils.
- .5 CAN/CGSB-8.1-88, Sieves, Testing, Woven Wire, Inch Series.
- .6 CAN/CGSB-8.2-M88, Sieves, Testing, Woven Wire, Metric.

### 1.3 DELIVERY, STORAGE AND HANDLING

- .1 Deliver, store and handle materials in accordance with Section 31 05 16 - Aggregate Materials.
- .2 Storage and handling requirements: Stockpile minimum 50% of total aggregate required prior to beginning operation.

### 1.4 MEASUREMENT FOR PAYMENT

- .1 **Aggregate Base and Subbase:** will be measured in metric tonnes (t) as taken from the weight slips, including all labour, materials and equipment necessary to acceptably supply, place, grade and compact the material.
- .1 Aggregates placed in excess of 110 % of the theoretical quantity, based on the specified measurements indicated on the Drawings will not be included for payment.
- .2 **Shoulder material:** will be measured in metric tonnes (t) as taken from the weight slips, including all labour, materials and equipment necessary to acceptably supply, place, grade and compact the material.
- .3 **RAP material:** when used for shouldering (and not supplied by the Town) will be measured in metric tonnes (t) as taken from the weight slips, including all labour, materials and equipment necessary to acceptably supply, place, grade and compact the material.
- .1 When RAP is supplied by the Town, the Contractor will be compensated for hauling,

placing, grading and compacting the material either by Unit Bid Price or by time and equipment at rates approved by the Owner or Consultant.

- .4 **Driveway Restoration:** Materials required (crushed stone, limestone or matching stone) for restoration of driveways will be measured in metric tonnes (t). Include all costs to supply, transport, place, spread, fine grade and compact the material similar to existing lines and grades shown on the Drawings or as directed by Owner or Consultant.

## 2 PRODUCTS

### 2.1 BASE AND SUBBASE MATERIALS

- .1 Granular: Material in accordance with Section 31 05 16 Aggregate Materials and following requirements:
- .1 Crushed rock or gravel.
  - .2 Gradations to be within limits specified when tested to ASTM C136 and ASTM C117. Sieve sizes to CAN/CGSB-8.1 CAN/CGSB-8.2. Products to be used to be as per table in Section 31 05 16 – Aggregate Materials.
  - .3 Liquid limit: to ASTM D4318, maximum 25.
  - .4 Plasticity index: to ASTM D4318, maximum 6.
  - .5 Crushed particles: at least 60% of particles by mass within each sieve designation ranges to have at least 1 freshly fractured face. Material to be divided into ranges using methods of ASTM C136.

### 2.2 SHOULDER MATERIAL

- .1 Shoulder material will be approved aggregate base material, except when the Owner or Consultant has specified that Reclaimed Asphalt Pavement (RAP) is to be used for shouldering.
- .2 Crushed Shoulder Material will be produced by the crushing and processing of rock or gravel to conform to the requirements of Section 31 05 16 – Aggregate Materials.

## 3 EXECUTION

### 3.1 TEMPORARY EROSION AND SEDIMENT CONTROL

- .1 Supply and install Temporary erosion and sedimentation control as per Section 01 35 43 – Project Specific Environmental Procedures.
- .2 Inspect, repair, and maintain erosion and sedimentation control measures during construction until permanent vegetation has been established.

### **3.2 PLACEMENT AND INSTALLATION**

- .1 The thickness of each aggregate layer shall conform to the typical roadbed classifications as shown on Standard Detail Drawing No.s 31 and 32, or as specified in the Drawings and Specifications.
- .2 Place granular subbase after subgrade is inspected and approved by Owner or Consultant.
- .3 Where the gradation of the subgrade soil and the aggregate are such that mixing of the two materials may occur, an approved geotextile fabric shall be placed.
- .4 Construct granular materials to depth and grade in areas indicated.
- .5 Ensure no frozen material is placed.
- .6 Place material only on clean unfrozen surface, free from snow and ice.
- .7 Place subbase material to full width in uniform layers not less than 300mm thick.
- .8 Place granular base after subbase is inspected and approved in writing by Owner or Consultant and by Contractor's Materials Testing Firm.
- .9 Place base materials on the subbase, shaped to proper grade and cross-section, in layers each to a thickness not less than 150 mm thick.
- .10 Shape each layer to smooth contour and compact to specified density before succeeding layer is placed.
- .11 Remove and replace that portion of layer in which material becomes segregated during spreading.
- .12 Where the roadbed being constructed is subject to through traffic, conduct operations so that through-traffic does not travel directly on an undercut surface or subgrade, unless approved by the Owner or Consultant.

### **3.3 CONSTRUCTION EQUIPMENT**

- .1 Compaction Equipment: Vibratory rollers or vibrating plate compactors capable of obtaining required material densities.
  - .1 Replace or supplement equipment that does not achieve specified densities.
- .2 Water Distributors: Capable of applying water uniformly.

### **3.4 COMPACTION**

- .1 Compact each granular material to density not less than 95% maximum dry density to ASTM D698.
- .2 Shape and roll alternately to obtain smooth, even and uniformly compacted base.
- .3 Apply water as necessary during compacting to obtain specified density.
- .4 In areas not accessible to rolling equipment, compact to specified density with mechanical tampers approved in writing by Owner or Consultant.
- .5 Correct surface irregularities by loosening and adding or removing material until surface is

within specified tolerance.

### 3.5 PROOF ROLLING

- .1 For proof rolling use equipment that is intended to be used throughout project.
- .2 Proof roll at level in granular materials as indicated.
- .3 Make sufficient passes with proof roller to subject every point on surface to three separate passes.
- .4 Where proof rolling reveals defective granular materials, remove defective materials to depth and extent as directed by Owner or Consultant and Materials Testing Firm and replace with new materials in accordance with this section at no extra cost.

### 3.6 TESTING

- .1 Testing: Granular materials placed for roadway construction, roadway widening, curb and sidewalk projects to conform to the following compaction requirements:
  - .1 Materials Testing Firm shall be engaged by Contractor to perform all laboratory and field-testing requirements for granular materials.
  - .2 Materials Testing Firm shall be registered in the Province of New Brunswick and be qualified in the Work required.
  - .3 All results from the laboratory and field-testing program shall be submitted to the Owner or Consultant for review and approval once tests are completed.
  - .4 Field-testing of the aggregate materials shall be performed using a calibrated nuclear densometer.
  - .5 At the end of project, Contractor is to submit final report encompassing all laboratory and fields-testing results.
  - .6 As a minimum testing frequency, Contractor's Materials Testing Firm is to complete compaction testing of aggregates as per following table:

#### .1 Minimum Testing Frequency for Compaction of Soils

Item No.	Description	Test Method	Testing Frequency	Remarks
1	Trench Work (Water & Sewer)	ASTM D698	Minimum of one Proctor test is required per material type prior to placement. Nuclear density testing done to create a compaction pattern for both bedding and backfill to establish a benchmark to continue until a noticeable change in material. Once procedure is established, Contractor must ensure that the recommended method is followed on	Nuclear gauge testing. Owner or Consultant to make field notes on method and results.

Item No.	Description	Test Method	Testing Frequency	Remarks
			all trenches. During pipe trench backfilling, minimum of one (1) nuclear density test per 100m of trench work, for each 300mm lift, or equivalent for shorter trenches.	
2	Subgrade Testing (Borrow or Fill Sections)	ASTM D698  Proof Rolling	Minimum of one Proctor test is required per material type prior to placement. One nuclear density field test section per material type - to develop a definite compaction procedure (equipment, lift thickness, moisture application and number of passes), which will produce the required density.  Visual deflection test of all subgrade surfaces with a fully loaded tandem truck.  Minimum one (1) nuclear density test per 20 m of street, for each 300 mm lift.	Nuclear gauge testing.
3	Subgrade Testing (Cut Sections)	Proof Rolling	Carry out visual deflection test of all subgrade surfaces with a fully loaded tandem truck.	Owner or Consultant to verify in field notes that this was carried out and record the results.
4	Granular Base and Subbase	ASTM D698	Minimum one (1) test per 25 m of street, for each lift of material added.	Nuclear gauge testing.
<p>Note: Frequency or numbers of tests may be increased at any time by the Engineer when deemed necessary or if unfavorable results are recorded.</p>				

- .2 The Contractor shall be responsible for the interpretation of the QC test results and the determination of any action to be taken to ensure that all materials and work conform to the requirements of the Contract.

### 3.7 SITE TOLERANCES

- .1 Finished base surface shall be within plus or minus 10mm of established grade and cross

section but not uniformly high or low.

- .2 Correct surface irregularities by loosening and adding or removing material until surface is within specified tolerance.
- .3 Deviation from the grades on the plans will result in regrading of the unacceptable areas at the contractor's expense.

### **3.8 PROTECTION**

- .1 Maintain finished granular materials in condition conforming to this Section until succeeding material is applied or until acceptance by Owner or Consultant.
- .2 Protect newly graded areas from traffic and erosion and maintain free of trash or debris.

### **3.9 ROADWAY SHOULDERS**

- .1 Spread shoulder material using a shoulder spreader of a type approved by the Owner or Consultant. This shoulder spreader shall be capable of placing shoulder material over a width and to a depth as required and shall be constructed so that it will not place or leave any material on the pavement.
- .2 Clean off immediately any shoulder material that should fall on the pavement.

### **3.10 CLEANING**

- .1 Refer to Section 01 00 00 – Project Specific General Requirements.

**END OF SECTION**

## **1 GENERAL**

### **1.1 DESCRIPTION**

- .1 This Section specifies the requirements for construction of asphalt concrete pavement. It includes supplying and placing asphalt concrete material in accordance with these specifications and detailed drawings or as directed by the Owner.

### **1.2 REFERENCE STANDARDS**

- .1 ASTM D698-00, Standard Test Methods for Laboratory Compaction Characteristics of Soil Using Standard Effort (12,400 ft-lbf/ft<sup>3</sup> (600 kN-m/m<sup>3</sup>)).
- .2 ASTM D977-20, Standard Specification for Emulsified Asphalt.
- .3 ASTM D995-95, Standard Specification for Mixing Plants for Hot-Mixed, Hot-Laid Bituminous Paving Mixtures.
- .4 ASTM D2397M-20, Standard Specification for Cationic Emulsified Asphalt.
- .5 AASHTO M 332-21 Standard Specification for Performance-Graded Asphalt Binder Using Multiple Stress Creep Recovery (MSCR) Test.
- .6 AASHTO R35 Standard Practice for Superpave Volumetric Design for Asphalt Mixtures

### **1.3 DEFINITIONS**

- .1 For the purposes of this Specification, the following definitions apply:
- .1 Hot Mix Asphalt (HMA) – hot-mixed, hot-laid Superpave asphalt concrete.
- .2 Lot – The asphalt concrete material of one mix type placed in one day, per street.
- .3 Reclaimed Asphalt Pavement (RAP) – processed HMA material that is recovered by partial or full depth removal.

### **1.4 MEASUREMENT FOR PAYMENT**

- .1 The unit of measurement for payment for hot-mix, hot-laid asphalt concrete shall be the number of tonnes (t) of HMA, scale weighed, acceptably incorporated into the Work at the specified thickness, including all preparatory work.
- .1 Any HMA quantity placed in excess of 110% of the theoretical quantity in tonnes (t) shall not be included for payment unless otherwise authorized in writing by the Owner or Consultant. The theoretical HMA quantity shall be determined by the following formula: (specified thickness in mm x final measured asphalt concrete pavement area in m<sup>2</sup> x in place density in kg/m<sup>3</sup>) / 1,000,000.
- .2 All HMA that is delivered to the Site shall be accompanied by an electronic truck weigh ticket showing the truck number, type of HMA, Contract number, truck loading time at the

- hot-mix plant, tare mass to the nearest 50 kg, gross mass to the nearest 50 kg, net mass in kg and driver's signature. The tare mass for the truck shall include the vehicle, operator, fuel, spare tire, etc.
- .3 The Contractor shall be responsible for ensuring that the truck weigh ticket for each load is handed to the Owner or Consultant inspecting the asphalt paving operation at the time the delivery truck unloads at the paving Site. The Owner or Consultant will not accept any responsibility for delivery tickets that are not submitted at the proper time, or are submitted in groups after the delivery trucks have left the Site. Asphalt weigh tickets are to be signed on-Site by the Owner or Consultant during placement, with one (1) copy being retained by the Owner or Consultant and the other copy to be submitted with the Contractor's monthly invoice.
- .4 The following items shall not be measured for payment and shall be considered as incidental to the Work:
- .1 Hauling of HMA to the Site, sweeping and cleaning, and Site restorations.
  - .2 Sampling and testing of aggregates, calibration of asphalt plants, and trial batches.
  - .3 Removal of surplus granular material as a result of fine grading, including disposal off-site.
  - .4 Cutting existing asphalt concrete edges prior to resurfacing.
  - .5 Handwork to complete HMA paving around catch basins, street hardware, valves, etc., to complete swales or any other place where handwork is carried out concurrently with the spreader operation.
  - .6 Removal and replacement of any part of the Work not meeting the requirements of the Specifications; and
  - .7 The use of tack coat at joints, curb lines, aprons, around street hardware and catch basin frames or any other vertical faces.
- .5 Measurement for payment of HMA padding shall be the number of tonnes (t) scale weighed and acceptably incorporated into the Work.
- .6 Measurement for payment of HMA patching shall be the number of tonnes (t) scale weighed and acceptably incorporated into the Work.
- .7 Measurement for payment of asphalt concrete curb and asphalt concrete sidewalk shall be per metre (m) of curb or sidewalk, including all labour, materials and equipment necessary to complete the Work.
- .8 Measurement for payment of miscellaneous HMA work shall be the number of tonnes (t) scale weighed miscellaneous HMA acceptably incorporated into the Work.
- .9 Measurement for payment for cold milling shall be per square metre (m<sup>2</sup>) of asphalt concrete pavement acceptably removed and hauled from the Site to an approved location.
- .10 Tack coat that is specified to treat the entire cold milled, aged asphalt concrete or any other surfaces, shall be measured for payment per square metre (m<sup>2</sup>) of acceptably tack-coated surface.

## 1.5 PRICE ADJUSTMENT

- .1 A payment adjustment for the change in price of asphalt binder between the month preceding the month in which tenders were opened for the Contract and the time of the placement of the HMA will apply to the quantity of asphalt binder (cement) accepted into the Work and will be calculated as follows if the price index between the two (2) months differs by more than 5%:
- .1 PA = Payment adjustment for asphalt binder in dollars.
- .2 T = PG asphalt binder price index for the month prior to tender opening.
- .3 P = PG asphalt binder price index for the month of paving.
- .4 Q = Quantity of asphalt binder in tonnes.
- When  $P \geq 1.05 T$ , the Contractor receives additional payment as follows:  
 $PA = (P - 1.05T) \times Q$
- When  $P < 0.95 T$ , the Owner receives a credit as follows:  
 $PA = (0.95T - P) \times Q$
- .5 This payment adjustment for the change in the price of asphalt binder during the Work is not considered to be extra work.
- .2 The Asphalt Binder Price Index used for the price adjustment will be from the New Brunswick Department of Transportation and Infrastructure.

## **2 MATERIALS**

### **2.1 BITUMINOUS TACK COAT**

- .1 Tack coat shall be RS-1 or CRS-1 Grade asphalt emulsion and shall conform with the provisions of ASTM D977 and ASTM D2397, respectively.
- .2 Non-tracking emulsion shall be diluted with 40% water and shall meet the requirements of NBDTI Table 259-1 – Non-tracking Emulsion Requirements (Prior to Dilute).

### **2.2 ASPHALT BINDER**

- .1 Asphalt binder shall meet the requirements of AASHTO M332, Table 1 – Performance Graded Asphalt Binder Specification.
- .2 Unless otherwise specified in the project detailed drawings or specifications or at the direction of the Owner, the performance-graded (PG) asphalt shall be PG 58S-28.

### **2.3 COARSE AGGREGATE**

- .1 Coarse aggregate shall be prepared by crushing rock and shall consist of hard, sound, durable particles, free from adherent coatings, shale, clay, loam, schist, and other soft or disintegrated pieces of deleterious substances.
- .2 Coarse aggregate is the portion retained on the 4.75 mm sieve, tested in accordance with

- .3 ASTM C136 and shall meet the physical requirements of Table 2.7.1.1. and Table 2.7.1.2.
- .4 Coarse aggregate may be accepted or rejected on the basis of past performance.

## 2.4 FINE AGGREGATE AND BLENDING SAND

- .1 Fine aggregate shall be prepared by crushing rock or screening a manufactured sand and shall consist of hard, sound, durable particles, free from adherent coatings, shale, clay, loam, schist, and other soft or disintegrated pieces of deleterious substances.
- .2 Fine aggregate shall be the portion passing the 4.75 mm sieve, when tested in accordance with ASTM C117 and C136, and shall meet the physical requirements of Table 2.7.1.1 and Table 2.7.1.2.
- .3 Blending sand may be used up to a maximum of 10% of the total mass of the aggregate fraction of the asphalt concrete mix to achieve the specified mix properties. Blending sand shall have 100% passing the 9.5 mm sieve prior to introduction to the asphalt plant cold feed.
- .4 Fine aggregate and blending sand may be accepted or rejected on the basis of past performance.

## 2.5 RECLAIMED ASPHALT PAVEMENT (RAP)

- .1 All RAP shall meet the processing, quality, and use guidelines in NCHRP Report 452. The coarse aggregate fraction of the RAP shall meet the aggregate physical properties criteria in NBDTI Standard Specifications for Highway Construction, Table 261-1: Physical Requirements for Coarse Aggregate.

## 2.6 ANTI-STRIPPING ADMIXTURES

- .1 If tensile strength ratio (TSR) testing performed during the asphalt concrete mix design phase indicates that an anti-stripping admixture is required, an anti-stripping admixture shall be added to the asphalt concrete mix at a dosage at which the TSR specification is met.
- .2 Anti-stripping admixtures shall be from the list below or approved NBDTI admixtures unless otherwise approved by the Owner.

### Approved Anti-stripping Admixtures

Product	
Redicote 82-S	Pave Bond T Lite
Redicote C-3082	Travcor 4505
Redicote C-2914	Innovalt W
Rediset LQ-1102	Evotherm M1
Ad-here LOF 65-00	Cecabase RT
Ad-here 7700	Zydex Zycotherm SP
Zydex Zycotherm	Road Science WarmGrip N1

## 2.7 ASPHALT CONCRETE PAVEMENT

.1 Asphalt concrete pavement shall be dense graded hot laid plant mix conforming to the requirements of AASHTO M 323.

### .1 Superpave Asphalt Concrete Mix Requirements

Sieve Size ASTM Designation		Type B	Type C	Type D
		% (by mass) Passing Each Sieve		
Coarse Aggregate	25.0 mm	100.0	-	-
	19.0 mm	84.0 – 98.0	-	-
	12.5 mm	60.0 – 87.0	88.0 – 98.0	100.0
	9.5 mm	51.0 – 75.0	68.0 – 90.0	76.0 – 98.0
	6.3 mm	41.0 – 66.0	54.0 – 77.0	60.0 – 84.0
Fine Aggregate	4.75mm	34.0 – 60.0	46.0 – 69.0	52.0 – 70.0
	2.36 mm	22.0 – 50.0	28.0 – 58.0	36.0 – 65.0
	1.18 mm	12.0 – 42.0	20.0 – 50.0	20.0 – 55.0
	600 µm	6.0 – 32.0	13.0 – 40.0	16.0 – 44.0
	300 µm	3.0 – 20.0	7.0 – 27.0	8.0 – 26.0
	150 µm	2.0 – 8.0	3.0 – 10.0	4.0 – 12.0
	75 µm	2.0 – 6.0	2.0 – 6.0	2.0 – 6.0
	<b>Physical Requirements for Asphalt Concrete</b>			
Air Voids %		3.00 – 5.00	3.00 – 5.00	3.00 – 5.00
VMA % for 100 gyration mix		13.5	14.5	15.5
VMA % for 75 gyration mix		13.0-14.5	14.0 – 15.5	15.0 – 16.5
Voids Filled with Asphalt %		70.0 – 75.0	70.0 – 75.0	70.0 – 77.0
Tensile Strength Ratio (TSR) % (min) ASTM D4867		80.0	80.0	80.0
Dust to Binder Ratio		0.6 – 1.2	0.6 – 1.2	0.6 – 1.2

### .2 Physical Requirements for Asphalt Concrete Aggregates

Physical Requirements for Coarse Asphalt Aggregate		
Freeze/Thaw % (max)	MTO LS - 614	
	0.3 to < 3 million Design ESALs	16.0
	≥ 3 million Design ESALs	14.0
Micro-Deval % (max)	MTO LS - 618	
	0.3 to < 3 million Design ESALs	16.0
	≥ 3 million Design ESALs	15.0
Petrographic No. (max) <sup>1</sup>	MTO LS - 609	
	0.3 to < 3 million Design ESALs	200
	≥ 3 million Design ESALs	180
Flat & Elongated Particles	% (max @ 4:1) ASTM D4791	
	0.3 to < 3 million Design ESALs	20.0
	≥ 3 million Design ESALs	15.0
Crushed Particles	ASTM D5821	
	0.3 to < 3 million Design ESALs	95
	≥ 3 million Design ESALs (min % by wt., one face)	95
	0.3 to < 3 million Design ESALs	

	≥ 3 million Design ESALs ESALs (min % by wt., two face)	80
Absorption % (max)	ASTM C 128	2.0
<b>Physical Requirements for Fine Asphalt Aggregate</b>		
Micro-Deval % (max)	MTO LS - 619 0.3 to < 3 million Design ESALs ≥ 3 million Design ESALs	20 17.0
Uncompacted Void Content % (min)	ASTM C1252	45.0
Notes: 1) Not mandatory, the Owner reserves the right to obtain a Petrographic No.  2) The allowable Micro-Deval surface Fine Aggregate shall be Max % Loss = 19.0, if the Micro-Deval on Coarse Aggregate is ≤ 12.0, provided that the Coarse Aggregate is from the same source.		

## 2.8 SUPERPAVE HMA MIX DESIGN(S)

### .1 Superpave HMA Design Mix Formula (DMF):

- .1 Preparation and submission of an asphalt DMF for the Owner's approval is the responsibility of the Contractor.
- .2 The Contractor shall use a qualified, independent laboratory to design the asphalt concrete mix. The mix design shall be completed within the same calendar year as the Work is to be completed unless otherwise approved by the Owner.
- .3 The asphalt concrete mix design shall follow AASHTO R35 Standard Practice for Superpave Volumetric Design for Hot-Mix Asphalt (HMA). The asphalt mix design shall meet the requirements of AASHTO M 323 Standard Specification for Superpave Volumetric Mix Design (See Section 2.7.1.1). The number of design gyrations shall be in accordance with project-specific detailed drawings or specifications or as directed by the Owner.
- .4 The amount of reclaimed asphalt pavement (RAP) in the hot mixed recycled asphalt concrete mix shall not exceed 15% of the total mass of the combined materials.

### .2 Superpave HMA Job Mix Formula (JMF):

- .1 The JMF shall be submitted to the Owner prior to beginning asphalt concrete production. The JMF shall include the following information:
  - .2 The percentage by mass of each aggregate to be used in the asphalt concrete mix.
  - .3 The percentage by mass passing the 4.75 mm and 0.075 mm sieves of the combined aggregates.
  - .4 The asphalt binder content.
  - .5 The asphalt binder supplier and grade.
  - .6 The production and compaction temperature of the asphalt mix.
  - .7 The type of anti-stripping admixture in the mix, if applicable.
  - .8 The JMF target values shall not deviate from the DMF values by more than the

following:

+/- 6% for material passing the 4.75 mm sieve.

+/- 1% for material passing the 0.075 mm sieve.

+/- 0.4% for asphalt cement content.

- .9 A maximum of three (3) JMF adjustments per mix type will be accepted. Any additional adjustments to the asphalt mix will require the design of a new DMF in accordance with item 2.8.1.

## **2.9 MATERIALS CERTIFICATION**

- .1 The Contractor shall submit a copy of the DMF for review and approval by the Owner ten (10) days before the beginning of asphalt concrete production. The Owner or a testing laboratory representing the Owner reserves the right to sample aggregates and asphalt binder from the Contractor at any time prior to or during paving for mix verification and ignition oven calibration purposes.
- .2 The Contractor shall submit a JMF to the Owner three (3) days prior to beginning asphalt concrete production. Any adjustments to the JMF during production shall be submitted 1 day prior to the adjustment being made.
- .3 The Contractor shall submit supplier test data and certification that the performance graded (PG) asphalt binder meets the requirements of AASHTO M332, Table 1 – Performance Graded Asphalt Binder Specification.
- .4 The Contractor shall submit a temperature-viscosity chart that provides optimum mixing and compaction temperature for the asphalt binder.
- .5 The Contractor shall submit test data from a qualified independent laboratory that demonstrates that the coarse and fine aggregates meet the requirements of AASHTO M 323 Standard Specification for Superpave Volumetric Mix Design (See Section 2.7.1.1)
- .6 The aggregates testing shall be completed within the same calendar year as the Work is to be completed unless otherwise approved by the Owner.

## **2.10 QUALITY CONTROL PLAN**

- .1 At least ten (10) days before the commencement of work, the Contractor shall submit to the Owner a Quality Control Plan (QCP) that includes, as a minimum, the following information:
- .2 Details of asphalt mix constituent materials sources and properties and evidence that all performance specifications are met.
- .3 Information on control of asphalt concrete and constituent materials during production including but not limited to details on handling, stockpiling, mixing, storage, and transportation procedures.
- .4 Placement and compaction procedures including detailed information on procedures to avoid segregation, paving and compaction joints, spreader and roller equipment details, and rolling patterns.

### **3 EXECUTION**

#### **3.1 PREPARATION FOR PLACEMENT OF ASPHALT CONCRETE**

##### **.1 Granular Materials:**

- .1 Immediately prior to placing any course of Superpave HMA on a granular material grade, the crushed rock or crushed gravel surface shall be fine graded to within ten (10) millimetres of design grade and compacted to a minimum of ninety-five percent (95%) of the maximum dry density as determined by Standard Proctor (ASTM D698).
- .2 HMA placement shall not be carried out if the roadbed is frozen. The granular grade shall be free of standing water at the time of HMA placement.

##### **.2 Existing Asphalt Concrete Pavement:**

- .1 Prior to placing any HMA, all HMA and concrete surfaces shall be clean of all loose, broken, and foreign materials. Milled surfaces shall be swept with a power broom. The Contractor shall carry out such cleaning, brooming and flushing, as necessary. All costs associated with cleaning, brooming and flushing shall be considered incidental to the Work.
- .2 The surface of a pavement upon which HMA is to be placed shall be dry at the time of HMA placement. An HMA course shall not be placed on a previously laid course until the temperature of the previous course is 60°C or less, and the paving equipment does not damage the previously laid course.

##### **.3 For asphalt patching and restoration, including utility trenches, slug work base repairs for new curb, and base repair for hardware adjustments, the existing asphalt concrete shall be saw cut or milled to make a clean joint.**

##### **.4 Obtain Owner or Consultant approval of milled keyways, and milled surface and/or base gravels before placement of tack coat and pavement.**

##### **.5 Frames and Appurtenances:**

- .1 The Contractor shall check and adjust all frames and appurtenances to grade, including longitudinal and transverse slopes.

##### **.6 Application of Tack Coat:**

- .1 Tack coat shall be applied to all cold-milled asphalt surfaces, all asphalt surfaces not paved within the past 24 hours, or any other surface specified by the Owner, prior to placement of HMA.
- .2 Tack coat shall be used at all joints, curb lines, aprons, around street hardware, frames and appurtenances, or any other vertical face(s) that the new asphalt concrete will terminate against, unless directed otherwise by the Owner.
- .3 Immediately before the application of tack coat, and prior to delivery of any HMA to the paving location, the Contractor shall carry out power or hand brooming when deemed necessary by the Owner.
- .4 The tack coat shall be applied in a uniform manner by means of a pressure distributor at a minimum diluted rate of 0.4 L/m<sup>2</sup>, or as directed by the Owner. Tack coat shall not be applied during wet weather or on a wet surface. Care shall be taken during the

application of tack coat to prevent the defacing of adjacent infrastructure. The tack coat shall be allowed to properly cure (break), with any traffic diverted until the tack coat has cured to eliminate tracking.

### 3.2 EQUIPMENT

- .1 The asphalt mixing plant shall meet the requirements of ASTM D995.
- .2 The paver shall be a self-powered, mechanical spreader capable of spreading asphalt concrete mixture true to line, grade, and cross-slope.
  - .1 The paver shall be equipped with screws that promote even distribution of the asphalt concrete mix in front of the screed, without segregation.
  - .2 The paver shall be equipped with a vibrating screed. The vibrating function of the screed shall be in operation at all times.
  - .3 The paver shall be equipped with a heater capable of preheating the screed and extensions. The heater shall be in operation at all times.
- .3 At a minimum, three rollers shall be used for compaction of asphalt concrete:
  - .1 A vibratory breakdown roller with a minimum mass of 8 t;
  - .2 A rubber tire roller equipped with means to prevent the asphalt concrete mix from adhering to the rubber tires;
  - .3 A steel drum finishing roller.
- .4 Trucks used to transport asphalt concrete from the plant to the paving Site shall have tight metal boxes free of foreign material.
  - .1 The trucks shall be equipped with tarpaulins of sufficient size to overhang the fully loaded truck boxes and be tight to the box to prevent air infiltration. Tarpaulins shall be used to cover the asphalt mix during transport and shall not be removed until immediately prior to dumping the load into the paver.

### 3.3 PLACEMENT

- .1 Base course asphalt concrete shall not be placed when conditions of rain prevail or when standing water is present upon the granular surface upon which paving is to occur.
- .2 Surface course asphalt concrete shall not be placed when weather conditions of fog or rain prevail, or when the surface upon which paving is to occur shows any sign of surface moisture.
  - .1 The surface upon which paving is to occur shall be free of any loose or foreign material prior to placing asphalt concrete.
  - .2 The surface upon which paving is to occur shall be at a minimum 5°C, and rising, prior to placing asphalt concrete.
- .3 The asphalt concrete shall be placed in a manner that ensures that the finished mat is smooth, free from surface defects, and is constructed with proper grades, cross-slopes, and road width.

- .4 The speed of the paver shall be matched to the rate of asphalt material delivery to ensure continuous operation of the paver.
- .5 All placement, spreading, and compaction shall occur only during daylight hours unless otherwise approved by the Owner.
- .6 Spreading of asphalt concrete by hand shall be kept to a minimum.
- .7 Broadcasting loose asphalt on an asphalt surface generated with a spreader is prohibited.
- .8 When spreading asphalt full width, placing by hand will be prohibited.
- .9 The compacted thickness of the asphalt concrete course shall be in accordance with detailed drawings or specifications or as directed by the Owner.
- .10 All placement of base course asphalt concrete is to be completed on or before October 31st.
- .11 All placement of surface course asphalt concrete is to be completed on or before October 15th.
- .12 Extension beyond October 15th seal and October 31st base will only be allowed upon written approval of the Owner.
- .13 Paving operations beyond the specified dates for seal asphalt (October 15th) and base asphalt (October 31st) will require Contractor to increase warranty to two (2) years total. Contractor to provide the warranty in writing.

### **3.4 COMPACTION**

- .1 A level of compactive effort suitable to achieve the specified in-place density of the asphalt concrete shall be used. The required level of compactive effort for a mix shall be determined by a rolling pattern established with the use of a nuclear density gauge.
- .2 The temperature range within which compaction shall occur shall be guided by data from the submitted asphalt binder temperature-viscosity chart.
- .3 Compaction equipment shall not sit idle on a hot asphalt mat.
- .4 Along infrastructure and in areas not accessible to full-sized rollers, the mixture shall be compacted with smaller equipment such as vibrating plate tampers or hand tampers.

### **3.5 QUALITY CONTROL (QC) TESTING**

- .1 The Contractor shall be totally responsible for quality control testing throughout every stage of the asphalt paving work to ensure that materials and workmanship meet the requirements of this Specification.
- .2 The Contractor shall engage a qualified independent laboratory to perform quality control testing of the asphalt concrete. The testing laboratory shall be approved by the Owner.
- .3 The approved testing laboratory shall perform a complete suite of Superpave tests on a loose sample of each asphalt concrete mix type produced daily. The asphalt concrete material shall meet the specifications of Table 261-12 from NBDTI Standard Specifications for Highway Construction, 2023 edition.

**.1 NBDTI Table 261-12 Acceptance Criteria**

<b>Test Properties</b>	<b>Criteria</b>
Air Voids	2.50% - 5.00%
Asphalt Binder Content	JMF $\pm$ 0.40
Percent Passing 4.75 mm Sieve	JMF $\pm$ 6.0
Percent Passing 75 $\mu$ m Sieve	JMF $\pm$ 1.0
Maximum Percent Passing 75 $\mu$ m Sieve	6.5%

- .4 The approved QC testing laboratory shall take 2 additional loose samples from each mix type daily for additional testing should the results of the first sample result in a dispute.
- .5 For each asphalt concrete mix type, the Contractor shall establish a rolling pattern using a nuclear density gauge. Upon completion of the establishment of the rolling pattern, the Contractor shall submit a copy to the Owner. The rolling pattern data shall be submitted on the same day on which it is established.
- .6 The approved testing laboratory shall sample a minimum of 2 core samples from the compacted asphalt concrete for laboratory measurement of density and thickness from each street paved daily. The in-place density shall be a minimum of 92.5% of the maximum theoretical relative density, as determined by testing of the daily loose asphalt concrete sample.
- .7 All HMA samples and cores shall be delivered by the Contractor, within 4 hours of sampling, to a Quality Assurance Laboratory designated by the Owner or Consultant.

**3.6 QUALITY ASSURANCE (QA) TESTING**

- .1 The Owner shall engage a qualified independent laboratory to perform quality assurance testing of the asphalt concrete.
- .2 The approved QA testing laboratory shall perform a complete suite of Superpave tests on a loose sample of each asphalt concrete mix type produced daily. The asphalt concrete material shall meet the specifications of Table 261-12 from NBDTI Standard Specifications for Highway Construction, 2023 edition (See Section 3.5.3.1).
- .3 The approved QA testing laboratory shall test a minimum of 2 core samples from the compacted asphalt concrete for laboratory measurement of density and thickness daily. The in-place density shall be a minimum of 92.5% of the maximum theoretical relative density, as determined by testing of the daily loose asphalt concrete sample.

**3.7 DEFECTS, REPAIRS, AND ACCEPTANCE/REJECTION**

- .1 The finished surface of any pavement course shall have a uniform texture and be free of surface defects which include but are not limited to:
  - .1 Individual bumps and dips that exceed 13.4 mm over a 3.0 m horizontal distance.
  - .2 Areas of segregation.
  - .3 Areas of excess or insufficient asphalt binder.
  - .4 Roller marks.

- .5 Cracking or tearing.
  - .6 Improper matching of longitudinal and transverse joints.
  - .7 Tire marks.
  - .8 Improper reinstatement of sample location.
  - .9 Improperly constructed patches.
  - .10 Improper cross slope.
  - .11 Fuel spills.
  - .12 Surface defects shall be removed and replaced or otherwise repaired to the satisfaction of the Owner; and,
  - .13 Repair should be done to full lane width to a minimum of 3.0 m each side of repair section.
- .2 Acceptance or rejection of a day's paving shall be determined by taking the mean of the QC and QA results.
- .1 If the results of the QC and QA testing are not within the tolerances provided in table below, the acceptance or rejection shall be determined using only the QA results.

**NBDTI Table 261-11 Acceptance Tolerance for Combining QA and QC Lot Test Results**

Mix Characteristics	Acceptance Tolerance Between QA and QC Test Results	
	Base Mix	Surface Mix
Air Voids	± 0.70	± 0.60
Asphalt Binder Content	± 0.30	± 0.20
Percent Passing 4.75 mm Sieve	± 5.0	± 3.0
Percent Passing 75 µm Sieve	± 0.5	± 0.4
<b>Note:</b> The Mix Characteristics are based on the sample mean of the Lot test results.		

- .3 If the mean of the QC and QA results meet the criteria in NBDTI Table 261-12: Acceptance Criteria, no further testing will be required.
- .4 If the mean of the QC and QA results do not meet the criteria in NBDTI Table 261-12: Acceptance Criteria, the Owner will require an extended warranty of a length to be determined by the Owner but not less than 2 years.

**END OF SECTION**

## **1 GENERAL**

### **1.1 DESCRIPTION**

- .1 This Section includes requirements for constructing cement concrete sidewalks, curbs and curbs and gutters to the lines, grades, dimensions, and typical cross-sections as per the project drawings and specifications or as directed by the Owner or Consultant.

### **1.2 REFERENCE STANDARDS**

- .1 ASTM C309-19, Standard Specification for Liquid Membrane-Forming Compounds for Curing Concrete.
- .2 ASTM C117, Standard Test Method for Materials Finer than 75-Micrometer (No. 200) Sieve in Mineral Aggregates by Washing.
- .3 ASTM C136M-9, Standard Test Method for Sieve Analysis of Fine and Course Aggregates.
- .4 ASTM D698-00, Standard Test Methods for Laboratory Compaction Characteristics of Soil Using Standard Effort (1-182,400 ft-lbf/ft<sup>3</sup> (600 kN-m/m<sup>3</sup>)).
- .5 ASTM D1751-18, Standard Specification for Preformed Expansion Joint Filler for Concrete Paving and Structural Construction (Nonextruding and Resilient Bituminous Types).
- .6 CSA A23.1:19/A23.2:19, Concrete Materials and Methods of Concrete Construction/Test Methods and Standard Practices for Concrete.
- .7 CSA A283:19, Qualification Code for Concrete Testing Laboratories.
- .8 CSA G30.3-M1983 (R1998), Cold-Drawn Steel Wire for Concrete Reinforcement.

### **1.3 ACTION AND INFORMATIONAL SUBMITTALS**

- .1 Portland cement shall be Normal, Type 10. Mix shall be submitted to the Owner or Consultant ten (10) working days prior to commencing work.
- .2 Product Data:
- .1 Submit WHMIS SDS for Hazardous Materials used.
- .2 Submit manufacturer's printed product literature, specifications and datasheet and include product characteristics, and limitations.
- .3 Inform Owner or Consultant of proposed source of materials and provide access for sampling minimum (ten) 10 working days prior to commencing work.
- .4 If materials have been tested by accredited testing laboratory testing laboratory approved by Owner or Consultant within previous 2 months and have passed tests equal to requirements of this specification, submit test certificates from testing laboratory showing suitability of materials for this project.
- .5 The ready-mix concrete supplier shall provide the Owner or Consultant the following:

- .1 Be certified in accordance with the requirements published by the Atlantic Concrete Association (ACA).
- .2 Current certification of conformance and plant membership
- .3 Current certification of conformance with CSA A23.1 with respect to the requirements for materials and methods in the proportioning, mixing, transport and inspection of cast-in-place Portland cement (PCC).

#### 1.4 MEASUREMENT FOR PAYMENT

##### .1 **New Concrete Curb & Gutter:** Excluding Excavation and Backfill

- .1 Installation of curb on new construction or on street reconstruction shall be made per metre (m) of curb which includes all labour, material and equipment necessary to complete the Work including curing and protection of the concrete.
- .2 Excavation and backfill shall be measured and paid in accordance with Section 31 24 13 – Roadway Construction, Embankments and Compaction.

##### .2 **Concrete Curb & Gutter Renewal:** Including Excavation and Backfill

- .1 In areas where construction is limited to the replacement of existing curb, measurement for payment shall be made per metre (m) of curb which shall include all labour, material and equipment necessary to complete the Work including cutting of asphalt, all excavation (excluding rock), backfilling, compaction, curing and protection of the concrete.
- .2 Rock excavation shall be measured and paid in accordance with Section 31 24 13 – Roadway Construction, Embankments and Compaction.

##### .3 **New Concrete Sidewalk:** Excluding Excavation and Backfill

- .1 Installation of sidewalk on new construction or on street reconstruction shall be made per metre (m) of sidewalk and per square metre (m<sup>2</sup>) for variable width sidewalk. Measurement for payment shall include all labour, material and equipment necessary to complete the Work including curing and protection of the concrete.
- .2 Excavation and backfill will be measured and paid in accordance with Section 31 24 13 – Roadway Construction, Embankments and Compaction.

##### .4 **Concrete Sidewalk Renewal:** Including Excavation and Backfill

- .1 In areas where construction is limited to the replacement of existing sidewalk or placement of new sidewalk, measurement for payment shall be made per metre (m) of sidewalk and per square metre (m<sup>2</sup>) for variable width sidewalk. Measurement for payment shall include all labour, material and equipment necessary to complete the Work including cutting of asphalt, all excavation (excluding rock), backfilling, compaction, curing and protection of the concrete.
- .2 Rock excavation will be measured and paid in accordance with Section 31 23 33.01 – Excavating, Trenching and Backfilling.

- .5 **Variable width concrete sidewalk:** payment shall be the square metre (m<sup>2</sup>) of variable width sidewalk acceptably placed.
- .6 **Welded Wire Fabric:** shall be the number of square metres (m<sup>2</sup>) acceptably placed.
- .7 Saw cutting and construction of joints in concrete shall be considered incidental to the placement of concrete.

## 2 PRODUCTS

### 2.1 CONCRETE MIXES AND MATERIALS

- .1 Concrete curb and concrete curb and gutter:

.1 **Table: Portland Cement Concrete Curb Mix Requirements**

<b>Minimum Cement Content</b>	<b>380 kg/m<sup>3</sup> for a Slipform Curb Machine 400 kg/m<sup>3</sup> for Metal Forms</b>
Normal Maximum Size of Coarse Aggregate	20 mm
Maximum Sand Content by Weight of Total	40 %
Maximum Water/Cement Ratio by Mass (w/c)	0.45
Air Content (a/c)	5 % - 8 %
Maximum Compressive Strength at 28 Days	32 MPa
Slump (Slipform Curb Machine)	40 mm +/- 10 mm

- .2 Concrete sidewalk:

.1 **Table: Portland Cement Concrete Sidewalk Mix Requirements**

Minimum Cement Content	400 kg/m <sup>3</sup> for Metal Forms
Normal Maximum Size of Coarse Aggregate	20 mm
Maximum Sand Content by Weight of Total	40 %
Maximum Water/Cement Ratio by Mass (w/c)	0.45
Air Content (a/c)	5 % - 8 %
Maximum Compressive Strength at 28 Days	32 MPa
Slump	80 mm +/- 20 mm

- .3 Welded wire fabric (mesh) shall be installed in sidewalk at non-residential driveways and as follows:
  - .1 Wire gauge 6.
  - .2 Size of mesh 152 mm x 152 mm (MW18.7 x MW18.7).
  - .3 Welded wire manufactured to CSA G30.3-M.
- .4 Expansion joint filler on all sidewalk and as follows:

- .1 Six (6) meter intervals in sidewalk and isolation of structures including manholes, catch basins, valve boxes, light posts, adjacent to buildings, etc.:
- .2 Joint filler to be full depth of sidewalk.
  - .1 Pre-moulded bituminous fiber board, conforming to ASTM D1751.
  - .2 Deck-O-Foam expansion joint filler (sealant required).
  - .3 Approved equivalent.
- .5 Expansion joint filler sealant on all sidewalk and as follows:
  - .1 Sealant to be self-leveling polyurethane sealant:
    - .1 SikaFlex 2C 2L.
    - .2 Sonolastic SL 2.
    - .3 Approved equivalent.
- .6 Curing agent: to ASTM C309 for cast-in-place concrete:
  - .1 Curing agent "Liquid Membrane-Forming Compounds for Curing Concrete".
- .7 Granular subbase and base: material to Section 31 05 16 - Aggregate Materials and following requirements:
  - .1 300 mm (fill sections) - Subbase pit-run gravel, crushed gravel or crushed rock.
  - .2 150 mm - Base crushed gravel or crushed rock.
  - .3 Gradations: within limits specified when tested to ASTM C136 and ASTM C117.
- .8 Non-staining mineral type form release agent: chemically active release agents containing compounds reacting with free lime to provide water-soluble soap.

### **3 EXECUTION**

#### **3.1 GRADE PREPARATION**

- .1 Prepare grade in accordance with Section 31 24 13 – Roadway Construction, Embankments and Compaction.
- .2 Construct embankments using excavated material free from organic matter or other objectionable materials.
  - .1 Dispose of surplus and unsuitable excavated material in approved location on Site or off-site.
- .3 When constructing embankment provide for minimum 0.6 m shoulders, where applicable, outside of neat lines of concrete.
- .4 Place fill in maximum 150 mm layers and compact to minimum 95% of maximum dry density to ASTM D698.

### **3.2 GRANULAR SUBBASE AND BASE**

- .1 Obtain Owner or Consultant approval of subgrade before placing granular subbase.
- .2 Place granular subbase and base material to lines, widths, and depths as per the project drawings and specifications.
- .3 Compact granular subbase and base in maximum 150 mm layers to minimum 95% of maximum density to ASTM D698.

### **3.3 CONCRETE**

- .1 Obtain Owner or Consultant approval of granular base prior to placing concrete curb and sidewalk.
- .2 Obtain Owner or Consultant approval of reinforcing steel prior to placing concrete sidewalk.
- .3 Immediately after floating, give sidewalk surface uniform broom finish to produce regular corrugations not exceeding 2 mm deep, by drawing broom side to side across sidewalk.
- .4 Provide edging as indicated with 10 mm radius edging tool.
- .5 Immediately after floating, give curb surface uniform broom finish to produce regular corrugations not exceeding 2 mm deep, by drawing broom parallel with curb.

### **3.4 QUALITY CONTROL/QUALITY ASSURANCE**

- .1 Engage services of qualified Professional Engineer licensed in New Brunswick, Canada to perform all sampling and testing.
  - .1 Quality Control testing is to be performed on all concrete to ensure it conforms to the requirements of the specifications.
  - .2 All testing conducted in accordance with CSA-A23.1 / A23.2.
  - .3 Minimum testing frequency:
    - .1 Slump, air test and compressive strength on each of the first two loads.
    - .2 Slump, air test and compressive strength on every third load after first two loads.
    - .3 Slump and air test is to be done on the first portion of load prior to placement.
    - .4 Compressive strength test shall consist of three concrete cylinders. Compressive strength testing shall be done at seven days and twenty-eight days. Third cylinder is spare.
  - .4 Lab used to do concrete testing shall be certified with CSA A283.
  - .5 All test results are to be submitted to Owner or Consultant as soon as tests are completed.

- .6 All lab and field test results shall be recorded on Concrete testing Summary forms and submitted to Owner or Consultant at end of project. Forms to be developed and submitted to Owner or Consultant for approval prior to use.
- .7 Owner or Consultant has the authority to assign a quality assurance designate to perform testing on concrete used.

### **3.5 TOLERANCES**

- .1 Finish surfaces to within 3 mm in 3 m as measured with 3 m straightedge placed on surface.

### **3.6 EXPANSION AND CONTRACTION JOINTS**

- .1 Install control saw cuts at 3.0 m intervals for curb once concrete surface has cured. Saw cut shall be 6 mm wide and 25 mm deep.
- .2 Install full depth expansion joints at intervals of 6 m.
- .3 Install control saw cuts at 1.5 m intervals for sidewalk once concrete surface has cured. Saw cut shall be 6 mm wide and 25 mm deep.
- .4 When sidewalk adjacent to curb, make joints of curb, gutters and sidewalk coincide.

### **3.7 ISOLATION JOINTS**

- .1 Install isolation joints around manholes and catch basins and along length adjacent to concrete curbs, catch basins, buildings, or permanent structure.
- .2 Install full depth joint filler in isolation joints as indicated.
- .3 Seal isolation joints with sealant.

### **3.8 CURING**

- .1 Cure concrete by adding moisture continuously in accordance with CSA-A23.1/A23.2 to exposed finished surfaces for minimum 1 day after placing, or sealing moisture in by curing compound.
- .2 Where burlap used for moist curing, place two prewetted layers on concrete surface and keep continuously wet during curing period.
- .3 Apply curing compound evenly to form continuous film, in accordance with manufacturer's requirements.

### **3.9 BACKFILL**

- .1 Allow concrete to cure for 7 days prior to backfilling.
- .2 Backfill to designated elevations with material as directed by Owner or Consultant.

- .1 Compact and shape to required contours.

### **3.10 ADDITIONAL GENERAL REQUIREMENTS**

- .1 Water is not to be added to the concrete other than at the batch plant.
- .2 Maximum time limit from batching to placing of concrete is 120 minutes.
- .3 Concrete to be retested for conformance to air content when more than 90 minutes have elapsed since batching.
- .4 Aggregates that are suspected to be reactive to alkali in cement are not to be used.
- .5 Only air entrainment agent admixture can be added to the concrete mix. Other admixtures can be added only with the approval of the Owner or Consultant.
- .6 Under adverse weather conditions, arrangement acceptable to the Owner or Consultant shall be made to prevent damage to fresh concrete. All curb and sidewalk are to be protected until completion and final acceptance of the Work.
- .7 For extreme temperatures below 5 degrees Celsius or above 27 degrees Celsius, adequate protection of the concrete shall be provided for the duration of the required curing period.
  - .1 During cold weather, adequate protection of the concrete shall be provided by means of heated enclosures, coverings, insulation, or suitable combination.
  - .2 During hot weather, adequate protection of the concrete shall be provided by means of water spray or saturated absorptive fabrics.
- .8 Concrete operations shall be completed by October 15 unless approved by the Owner or Consultant.
- .9 Any curb or sidewalk that needs to be replaced, is to be done from joint to joint.
- .10 Concrete sidewalk to be 100 mm in height, 150 mm across residential driveways and 200 mm across commercial/industrial/institutional driveways.
- .11 Control joints shall be placed at the bottom of the transition at each side and at the centre of driveway entrances.
- .12 Concrete curb and sidewalk to be depressed at driveway entrances, pedestrian crosswalks and other locations directed by Owner or Consultant.
- .13 Height of depression:
  - .1 Curb at driveway entrances to be 20 mm maximum above finished asphalt.
  - .2 Curb at access ramps shall be flush with finished asphalt.
- .14 Width of depressed curb and sidewalk to be as shown on respective Drawings.
- .15 Access to properties once concrete has attained sufficient strength is to be done immediately by Contractor and maintained until asphalt reinstatement is completed.
- .16 All curb or curb and gutter with a length greater than 20 m is to be placed by means of slipforming.
- .17 Curb and sidewalk shall be protected from all elements, including vandalism until completion of the Contract. Curb and sidewalk damaged before Final Acceptance of the Work shall be removed and replaced by the Contractor at no additional cost to the Owner.

**3.11 CLEANING**

- .1 Refer to Section 01 00 00 – Project Specific General Requirements.

**END OF SECTION**

## **1 GENERAL**

### **1.1 DESCRIPTION**

- .1 This Section describes the requirements for supplying and installing pavement markings, including materials (paint and markings, thinner, and glass reflective beads option), requirements for equipment, traffic control, application, and tolerances.

### **1.2 REFERENCE STANDARDS**

- .1 Canadian General Standards Board (CGSB)
- .1 CAN/CGSB-1.5-99, Low Flash Petroleum Spirits Thinner.
  - .2 CAN/CGSB 1.74-01, Alkyde Traffic Paint.
- .2 Health Canada / Workplace Hazardous Materials Information System (WHMIS)
- .1 Material Safety Data Sheets (MSDS).

### **1.3 ACTION AND INFORMATIONAL SUBMITTALS**

- .1 Product Data:
- .1 Submit manufacturer's printed product literature and data sheets for pavement markings and include product characteristics, performance criteria, physical size, finish and limitations.
  - .2 Submit two copies of WHMIS MSDS in accordance with Section 01 35 29 – Project Specific Health and Safety Requirements.

### **1.4 DELIVERY, STORAGE AND HANDLING**

- .1 Deliver, store and handle materials in accordance with manufacturer's written instructions.
- .2 Delivery and Acceptance Requirements: deliver materials to site in original factory packaging, labelled with manufacturer's name and address.
- .3 Storage and Handling Requirements:
- .1 Store materials in dry location and in accordance with manufacturer's recommendations in clean, dry, well-ventilated area.
  - .2 Replace defective or damaged materials with new.

### **1.5 MEASUREMENT FOR PAYMENT**

- .1 Pavement markings will be measured by lump sum.

## **2 PRODUCTS**

### **2.1 MATERIALS**

- .1 Paint: in accordance with NBDTI Standard Specifications, latest edition, Item 571 and the following requirements:
  - .1 To MPI -EXT 2.1B, Alkyd zone/traffic marking.
  - .2 Paints: in accordance with MPI recommendation for surface conditions.
    - .1 Paints: maximum VOC limit 100 g/L.
  - .3 Colour: to MPI listed, white and yellow.
- .2 Thinner: to MPI listed manufacturer.
- .3 Glass reflective beads: type suitable for application to wet paint surface for light reflectance.

## **3 EXECUTION**

### **3.1 EXAMINATION**

- .1 Verification of Conditions: verify conditions of substrates and surfaces to receive pavement markings previously installed under other Sections or Contracts are acceptable for product installation prior to pavement markings installation.
  - .1 Visually inspect substrate in presence of Owner or Consultant.
- .2 Pavement surface: dry, free from water, frost, ice, dust, oil, grease and other deleterious materials.
- .3 Proceed with Work only after unacceptable conditions have been rectified.

### **3.2 EQUIPMENT REQUIREMENTS**

- .1 Paint applicator: approved pressure type with positive shut-off distributor capable of applying paint in single, double and dashed lines and capable of applying marking components uniformly, at rates specified, and to dimensions as indicated.
- .2 Distributor: capable of applying reflective glass beads as overlay on freshly applied paint.

### **3.3 APPLICATION**

- .1 Pavement markings: laid out by Owner or Consultant.
- .2 Apply paint in accordance with NBDTI Standard Specifications, latest edition, Item 571.
- .3 Do not thin paint unless approved by Owner or Consultant.

- .4 Symbols and letters to dimensions indicated.
- .5 Paint lines: of uniform colour and density with sharp edges.
- .6 Thoroughly clean distributor tank before refilling with paint of different colour.
- .7 Apply glass beads at rate of 0.5 kg/l of painted area immediately after application of paint.

### **3.4 TOLERANCE**

- .1 Paint markings: within plus or minus 12 mm of dimensions indicated.
- .2 Remove incorrect markings, at no cost to the Owner.

### **3.5 CLEANING**

- .1 Progress Cleaning: clean in accordance with Section 01 00 00 – Project Specific General Requirements.
  - .1 Leave Work area clean at end of each day.
- .2 Final Cleaning: upon completion remove surplus materials, rubbish, tools and equipment in accordance with Section 01 00 00 – Project Specific General Requirements.

### **3.6 PROTECTION OF COMPLETED WORK**

- .1 Protect pavement markings until dry.
- .2 Repair damage to adjacent materials caused by pavement marking application.

**END OF SECTION**

## **1 GENERAL**

### **1.1 DESCRIPTION**

- .1 This Section specifies the requirements for supplying and installing various items including concrete, chain link fence fabric, posts, braces and rails, tie wire fasteners, gates and gate frames, finishes, etc. as shown on the Drawings.

### **1.2 REFERENCE STANDARDS**

- .1 ASTM A53/A53M-22, Standard Specification for Pipe, Steel, Black and Hot-Dipped, Zinc-Coated, Welded and Seamless.
- .2 ASTM A653/A653M-22, Standard Specification for Steel Sheet, Zinc-Coated (Galvanized) or Zinc-Iron Alloy-Coated (Galvannealed) by the Hot-Dip Process.
- .3 ASTM C618-22, Standard Specification for Coal Fly Ash and Raw or Calcined Natural Pozzolan for Use in Concrete.
- .4 CAN/CGSB-138.1-96, Fabric for Chain Link Fence.
- .5 CAN/CGSB-138.2-96, Steel Framework for Chain Link Fence.
- .6 CAN/CGSB-138.3-96, Installation of Chain Link Fence.
- .7 CAN/CGSB-138.4-96, Gates for Chain Link Fence.
- .8 CSA-A3000-18, Cementitious Materials Compendium.

### **1.3 DELIVERY, STORAGE AND HANDLING**

- .1 Deliver, store and handle materials in accordance with manufacturer's written instructions.
- .2 Delivery and Acceptance Requirements: deliver materials to Site in original factory packaging, labelled with manufacturer's name and address.
- .3 Storage and Handling Requirements:
- .1 Store materials in accordance with manufacturer's recommendations.
  - .2 Store and protect pipes from damage.
  - .3 Replace defective or damaged materials with new.

### **1.4 MEASUREMENT FOR PAYMENT**

- .1 Payment shall be made per metre (m) of fence which includes the supply of all necessary materials, labour, and equipment for the supply and installation of all fencing, including, grading (cuts or fills), foundation excavation, and concrete footings whether in rock or common material.

- .2 Payment for gates shall be made under a unit price basis which includes the supply of all necessary materials, labour and equipment for the supply and installation of gates, including grading (cuts or fills), foundation excavation, and concrete footings whether in rock or common material.

## 2 PRODUCTS

### 2.1 MATERIALS

- .1 Concrete mixes and materials:
- .1 Nominal coarse aggregate size: 20-5.
  - .2 Compressive strength: 20 MPa minimum at 28 days.
  - .3 Additives: fly ash to CSA A3000 and ASTM C618.
- .2 Chain-link fence fabric: to CAN/CGSB-138.1.
- .1 Refer to CAN/CGSB-138.1 tables 2, 3 and 4 for type, class, style and grade desired.
  - .2 Type 1, Class A, style 2, Grade 2 constructed of 3.5 mm steel wire in a 50 mm mesh.
  - .3 Height of fabric: as indicated in design drawings.
- .3 Posts: to CAN/CGSB-138.2, 60 mm outside diameter (O.D), hot dipped galvanized steel pipe with 4 mm wall thickness, schedule 40 and complete with galvanized metal caps.
- .4 Top Rails: to CAN/CGSB-138.2, 43 mm outside diameter (O.D), hot dipped galvanized steel pipe with 3.6 mm wall thickness, schedule 40 and complete with sleeves that allow contraction and expansion. Stretcher bands must be steel bands (3 m x 19 mm) or aluminum bands (5 m x 19 mm). Stretcher bars must be 3 m x 19 mm.
- .5 Terminal and Gate Posts: to CAN/CGSB-138.2, 89 mm outside diameter (O.D), hot dipped galvanized steel pipe with 5.5 mm wall thickness, Schedule 40 and complete with galvanized metal caps and stretching bands and bars for attaching the fabric to the posts and bands for attaching the braces.
- .6 Braces: to CAN/CGSB-138.2. Gate, corner and end posts shall be braced by a centre rail of the same material as the top rail, between the gate corner, or end post and the next post.
- .7 Top and bottom tension wire: to CAN/CGSB-138.2, single strand, electro-galvanized steel wire.
- .8 Tie wire fasteners: steel wire.
- .9 Tension bar: to ASTM A653/A653M, 5 x 20 mm minimum galvanized steel.
- .10 Gates: to CAN/CGSB-138.4.
- .11 Gate frames: to ASTM A53/A53M, galvanized steel pipe, 43 mm outside diameter pipe for outside frame, 35 mm outside diameter pipe for interior bracing and all schedule 40.
- .1 Fabricate gates as indicated with electrically welded joints, and hot dip galvanized after welding.
  - .2 Fasten fence fabric to gate with twisted selvage at top.

- .3 Furnish gates with galvanized malleable iron hinges, latch and latch catch with provision for padlock which can be attached and operated from either side of installed gate.
- .4 Furnish double gates with chain hook to hold gates open and centre rest with drop bolt for closed position.
- .5 Gates over 4.4 m<sup>2</sup> in area shall have diagonal bracing, 33 mm O.D., schedule 40, hot dip galvanized and welded at joints.
- .12 Fittings and hardware: to CAN/CGSB-138.2, galvanized steel.
  - .1 Tension bar bands: 3 x 20 mm minimum galvanized steel or 5 x 20 mm minimum aluminum.
  - .2 Post caps to provide waterproof fit, to fasten securely over posts and to carry top rail.
  - .3 Overhang tops to provide waterproof fit, to hold top rails.
- .13 Grounding rod: 16 mm diameter copper well rod, 3 m long.

### **3 EXECUTION**

#### **3.1 EXAMINATION**

- .1 Verification of Conditions: verify conditions of substrate previously installed under other Sections or Contracts are acceptable for fence and gate installation in accordance with manufacturer's written instructions.
  - .1 Visually inspect substrate in presence of Owner or Consultant.
  - .2 Inform Owner or Consultant of unacceptable conditions immediately upon discovery.
  - .3 Proceed with installation only after unacceptable conditions have been remedied.

#### **3.2 PREPARATION**

- .1 Supply and install temporary erosion and sedimentation control measures to prevent soil erosion and discharge of soil-bearing water runoff or airborne dust to adjacent properties and walkways, according to requirements of authorities having jurisdiction.
- .2 Inspect, repair, and maintain erosion and sedimentation control measures during construction until permanent vegetation has been established.
- .3 Remove erosion and sedimentation controls and restore and stabilize areas disturbed during removal.
- .4 Grading:
  - .1 Remove debris and correct ground undulations along fence line to obtain smooth uniform gradient between posts.
    - .1 Provide clearance between bottom of fence and ground surface of 30 mm to 50 mm.

### **3.3 ERECTION OF FENCE**

- .1 Erect fence along lines as indicated and to CAN/CGSB-138.3.
- .2 Excavate post holes to dimensions indicated.
- .3 Space line posts 3 m apart, measured parallel to ground surface.
- .4 Space straining posts at equal intervals not to exceed 150 m if distance between end or corner posts on straight continuous lengths of fence over reasonably smooth grade, is greater than 150 m.
- .5 Install additional straining posts at sharp changes in grade.
- .6 Install corner post where change in alignment exceeds 10 degrees.
- .7 Install end posts at end of fence and at buildings.
  - .1 Install gate posts on both sides of gate openings.
- .8 Place concrete in post holes then embed posts into concrete to depths indicated.
  - .1 Extend concrete 50 mm above ground level and slope to drain away from posts.
  - .2 Brace to hold posts in plumb position and true to alignment and elevation until concrete has set.
- .9 Install fence fabric after concrete has cured, minimum of 5 days.
- .10 Install brace between end and gate posts and nearest line post, placed in centre of panel and parallel to ground surface.
  - .1 Install braces on both sides of corner and straining posts in similar manner.
- .11 Install overhang tops and caps.
- .12 Install top rail between posts and fasten securely to posts and secure waterproof caps and overhang tops.
- .13 Install bottom tension wire, stretch tightly and fasten securely to end, corner, gate and straining posts with turnbuckles and tension bar bands.
- .14 Lay out fence fabric. Stretch tightly to tension recommended by manufacturer and fasten to end, corner, gate and straining posts with tension bar secured to post with tension bar bands spaced at 300 mm intervals.
  - .1 Knuckled selvedge at bottom.
  - .2 Twisted selvedge at top.
- .15 Secure fabric to top rails, line posts and bottom tension wire with tie wires at 450 mm intervals.
  - .1 Give tie wires minimum two twists.
- .16 Install grounding rods as indicated on Drawings.

### **3.4 INSTALLATION OF GATES**

- .1 Install gates in locations as indicated on Drawings.

- .2 Level ground between gate posts and set gate bottom approximately 40 mm above ground surface.
- .3 Determine position of centre gate rest for double gate.
  - .1 Cast gate rest in concrete as directed by Owner or Consultant.
  - .2 Dome concrete above ground level to shed water.
- .4 Install gate stops where indicated on Drawings.

### **3.5 TOUCH UP**

- .1 Clean damaged surfaces with wire brush removing loose and cracked coatings. Apply two coats of organic zinc-rich paint to damaged areas as indicated.
- .2 Pre-treat damaged surfaces according to manufacturers' instructions for zinc-rich paint.

**END OF SECTION**

## **1 GENERAL**

### **1.1 DESCRIPTION**

- .1 This section specifies the requirements for supplying all tools, labour, equipment and materials required to restore the site to its original condition as shown on the drawings and/or as ordered all in accordance with this specification.

### **1.2 DELIVERY, STORAGE AND HANDLING**

- .1 Deliver, store and handle materials in accordance with Section 01 00 00 – Project Specific General Requirements and with manufacturer's written instructions.

### **1.3 MEASUREMENT FOR PAYMENT**

- .1 Measurement for payment for landscaping restoration work shall be in accordance with Sections 32 92 24 – Topsoil, Hydraulic Seeding and Sodding.
- .2 Measurement and payment for replacement of existing trees, shrubs, gardens, etc. with new materials shall be considered individually.
- .3 Measurement for payment for granular driveway restoration shall be the number of tonnes (t), which includes all labour, materials and equipment necessary to complete the work including excavation, removal and disposal of unsuitable or surplus excavated material. Supply, placement and compaction of granular material shall be in accordance with Section 32 11 23 – Aggregate Placement.
- .4 Measurement for payment for asphalt driveway restoration shall be the number of tonnes (t), which includes all labour and equipment necessary to complete the work including asphalt cutting, excavation, removal and disposal of unsuitable or surplus excavated material, application of bituminous tack coat on all existing surface and edges, supply, placement and compaction of hot mixed asphalt concrete surface mix Type "D". Supply, placement and compaction of granular material shall be in accordance with Section 32 11 23 – Aggregate Placement.
- .5 Measurement for payment for concrete driveway restoration shall be made per square metre, which includes all labour, materials and equipment necessary to complete the work including concrete cutting, excavation, removal and disposal of unsuitable or surplus excavated material, the concrete including reinforcement and dowels into existing driveway. Supply, placement and compaction of granular material shall be in accordance with Section 32 11 23 – Aggregate Placement.
- .6 Measurement for payment for brick paver driveway restoration shall be made per square metre, which includes all labour, material and equipment necessary to complete the work including excavation, removal and disposal of unsuitable or surplus excavated material, the sand levelling course and the brick pavers. Supply, placement and compaction of granular material shall be in accordance with Section 32 11 23 – Aggregate Placement.
- .7 Measurement for payment for steps, walkways and decorative retaining wall restoration

shall be made per square metre, which includes all labour, material and equipment necessary to complete the work including excavation, removal and disposal of unsuitable or surplus excavated material, as well as the concrete or the sand levelling course and brick as required. Supply, placement and compaction of granular material shall be in accordance with Section 32 11 23 – Aggregate Placement.

- .8 Driveways, steps, walkways and decorative retaining walls that require retention of existing aggregate, brick pavers or non-standard materials for restoration, shall be considered individually.

## **2 PRODUCTS**

### **2.1 AGGREGATE BASE AND SUBBASE MATERIAL**

- .1 Aggregate base and subbase material shall be in accordance with Section 31 05 16 – Aggregate Materials.

### **2.2 CRUSHER TAILINGS**

- .1 Crusher tailings shall be clean, non-plastic, free of deleterious materials and shall be natural or manufactured crusher dust obtained from crushing rock.

### **2.3 ASPHALT CONCRETE PAVEMENT**

- .1 Asphalt concrete driveways to be reinstated using hot mixed asphalt concrete surface mix Type D, or as indicated on project drawings.
- .2 Asphalt concrete pavement to be in accordance with Section 32 12 16 – Asphalt Paving.

### **2.4 LIMESTONE CRUSHED ROCK**

- .1 Limestone Crushed Rock shall be clean, non-plastic, free of deleterious materials and shall be natural limestone.
- .2 Limestone should match existing driveway limestone properties as best as possible, including aggregate size and dust content.

### **2.5 GRANULAR A STONE**

- .1 Granular A stone shall be clean, non-plastic, free of deleterious materials and shall be natural gravel or rock obtained from select quarries to the approval of Owner or Consultant.
- .2 Stone should match existing driveway stone properties as best as possible, including aggregate size and dust content.

### **3 EXECUTION**

#### **3.1 EXISTING LANDSCAPING**

- .1 Where proper restoration requires cutting back embankments or slopes on private property to obtain proper grade, the excavation shall be classed as extra excavation in accordance with Section 31 24 13 – Roadway Construction, Embankments and Compaction.
- .2 All topsoiling, seeding and/or sodding shall be in accordance with Section 32 92 24 – Topsoil, Hydraulic Seeding and Sodding.

#### **3.2 TREES, SHRUBS, GARDENS, ETC.**

- .1 Trees, Shrubs, gardens, etc. shall be protected from disturbance in so much as possible from construction activities. Where proper restoration requires removal of such, they shall be set aside for re-use or replaced as required, unless specified otherwise by the Owner or Consultant.
- .2 Where proper restoration requires removal of trees on private property, they shall be replaced with a suitable tree, unless specified otherwise by the Owner or Consultant.

#### **3.3 DRIVEWAYS**

- .1 Granular driveways shall be restored with the same material to match the width and overall thickness of the existing driveway.
  - .1 Where it is necessary to do restoration of driveways that are constructed of granular material not readily available at local quarries because of the type, gradation and colour, the Contractor must retain and stockpile the stone in the individual owner's driveway for use in driveway restoration.
- .2 Asphalt driveways shall be restored to match the width and the overall thickness of the existing driveway.
  - .1 The edge of existing asphalt to be restored shall be cut in a straight line to full depth using a cutting saw and shall receive an application of tack coat.
  - .2 Asphalt for driveways shall be hot mixed asphalt concrete in accordance with Section 32 12 16 – Asphalt Paving.
- .3 Concrete driveways shall be restored to match the width and the overall thickness of the existing driveway.
  - .1 Concrete for driveways shall be 150mm in thickness, unless specified otherwise by the Owner or Consultant, including reinforcement dowels placed into the existing driveway spaced at 600mm on centre. Concrete for driveways shall be in accordance with Section 32 16 00 – Curbs, Gutters and Sidewalks.

- .4 Brick Paver driveways shall be restored to match the width and to the overall thickness of the existing driveway.

### **3.4 CONCRETE AND/OR BRICK STEPS, WALKWAYS AND DECORATIVE RETAINING WALLS**

- .1 All concrete and/or brick steps, walkways and decorative retaining walls on private property affected by construction activities shall be restored to match the dimensions of the existing steps, walkway or decorative retaining wall.
- .2 The concrete and/or brick shall be in accordance with Section 32 16 00 – Curbs, Gutters and Sidewalks.

**END OF SECTION**

## **1 GENERAL**

### **1.1 DESCRIPTION**

- .1 This section specifies the requirements for supplying all tools, labour, equipment and materials required to restore the site to its original condition as shown on the drawings and/or as ordered all in accordance with this specification.
- .2 Reshaping of disturbed surfaces is to be completed and approved prior to the placement of the topsoil and sod.

### **1.2 DELIVERY, STORAGE AND HANDLING**

- .1 Deliver, store and handle materials in accordance with Section 01 00 00 – Project Specific General Requirements and with manufacturer's written instructions.

### **1.3 MEASUREMENT FOR PAYMENT**

- .1 Preparation of sub-grade for placing of topsoil will not be measured for payment.
- .2 Measurement shall be made for supplying, placing and spreading topsoil in cubic metres as determined from actual surface area covered and depth of topsoil specified.
- .3 Measurement shall be made for supplying and placing sod in square metres as determined from actual surface area covered.
- .4 Measurement shall be made for supplying and placing hydroseed in square metres as determined from actual surface area covered.
- .5 No payment will be made for watering and fertilizing of lawned areas as required;
- .6 No payment will be made for returning the following spring to fertilize.

## **2 PRODUCTS**

### **2.1 TOPSOIL**

- .1 Shall be fertile, friable soil, reasonably free from subsoil, clay lumps, stones, roots, weeds or other objectionable materials. Contain no toxic elements or growth inhibiting materials.
- .2 Finished surface free from:
  - .1 Debris and stones over 50 mm diameter.
  - .2 Coarse vegetative material, 10 mm diameter and 100 mm length, occupying more than 2% of soil volume.

- .3 Consistency: friable when moist.

## **2.2 SOD**

- .1 Sod Shall be # 1 Canada Nursery Sod cut at the source with approved and appropriate equipment to ensure an even thickness of 25mm to 38mm. The cut edge shall be clean and vertical.

## **2.3 HYDROSEED MIXTURE**

- .1 The mixture to be used for hydroseeding shall contain the following elements:
  - .1 Grass seed -135 kilograms per hectare
  - .2 Approved Mulch - 1350 kilograms per hectare
  - .3 Fertilizer sufficient to promote a densely matted growth.
  - .4 Organic base adhesive - 45 kilograms per hectare

## **2.4 FLEXIBLE REINFORCED MATRIX (FRM)**

- .1 Acceptable FRM products:
  - .1 Flexterra (FRM), as manufactured by Profile Products
  - .2 Flex Guard (FRM), as manufactured by Mat Inc.

## **3 EXECUTION**

### **3.1 EXAMINATION**

- .1 Lawned areas shall be restored within three (3) weeks of disturbance unless otherwise approved in writing. Lawn restoration shall be completed by an approved landscaping contractor.
- .2 Application of the FRM shall be in accordance with the manufacturer's recommended procedures.
- .3 The Contractor is to notify the Owner or Consultant 48 hours prior to placement of the FRM.

### **3.2 PREPARATION OF EXISTING GRADE**

- .1 Verify that grades are correct.
  - .1 If discrepancies occur, notify Owner or Consultant and do not start work until instructed by Owner or Consultant.

- .2 Grade soil, eliminate uneven areas and low spots, ensure positive drainage.
- .3 Grade areas adjacent to existing finished areas to make a smooth connection with these areas and to ensure proper drainage across finished surfaces.
- .4 Remove debris, roots, branches, stones in excess of [50] mm diameter and other deleterious materials.
  - .1 Remove soil contaminated with calcium chloride, toxic materials and petroleum products.
  - .2 Remove debris which protrudes more than [75] mm above surface.
  - .3 Dispose of removed material off site.

### **3.3 PLACING AND SPREADING OF TOPSOIL**

- .1 Place topsoil after Owner or Consultant has accepted subgrade.
- .2 Keep topsoil 15mm below finished grade for sodded areas.
- .3 Spread topsoil to 100mm minimum depth after settlement.
- .4 Manually spread topsoil/planting soil around trees, shrubs and obstacles.
- .5 Avoid spreading or grading in wet, frozen, or saturated state.

### **3.4 FINISH GRADING**

- .1 Grade to eliminate rough spots and low areas and ensure positive drainage.
  - .1 Prepare loose friable bed by means of cultivation and subsequent raking.

### **3.5 PLACING OF SOD**

- .1 After the area to be sodded has been top soiled as outlined above, the sod shall be laid lengthwise across the length of a slope. Sod shall be placed tightly together without gaps to eliminate surface area for weed growth. Joints in adjacent rows shall best staggered. If necessary, sod shall be cut to nearly match adjoining existing lawn areas. In no case shall sod be placed over existing grass. Sod shall be pounded to form a smooth uniform surface. On slopes greater than 3:1, every sod in the bottom three rows shall be pegged, and in every third row above, with pegs driven flush with the sod. During the establishment period, any break which may occur through slipping of sod shall be removed and replaced. No sod shall be laid when in a frozen condition or upon frozen ground.
- .2 During this period, any break which may occur through slipping of sod shall be removed and replaced. No sod shall be laid when in a frozen condition or upon frozen ground.
- .3 The Contractor shall water sodded areas in sufficient quantities and at a 'Frequency required to maintain optimum soil moisture condition to a depth of 75mm to 100mm until

such times as the sod is established. Any sod which turns yellow shall be replaced immediately.

- .4 Any sodded area which fails to grow satisfactorily shall be repaired at the Contractor's expense until such growth is achieved

### **3.6 WARRANTY**

- .1 Areas hydroseeded in the fall shall be fertilized the following spring with a slow release nitrogen fertilizer (25-15-10 or equivalent) at a rate of 3.65 grams per square metre. The area to be fertilized shall be examined prior to fertilizing and any bare patches re-seeded prior to application of fertilizer. Re-seeding and fertilizing shall be completed by May 15th of the following construction year.
- .2 Any hydroseeded area which fails to grow satisfactorily shall be repaired at the Contractor's expense until such growth is achieved. End-of-warranty inspection will be conducted by Owner or Consultant.

**END OF SECTION**

## **1 GENERAL**

### **1.1 DESCRIPTION**

- .1 This Section includes requirements for supplying and installing various diameters precast concrete manholes, catch basins, sluice boxes and valve chambers as shown on the associated drawings.

### **1.2 REFERENCE STANDARDS**

- .1 ASTM A48/A48M-22, Standard Specification for Gray Iron Castings.
- .2 ASTM A536-84(2019)e1, Standard Specification for Ductile Iron Castings.
- .3 ASTM C109/C109M-21, Standard Test Method for Compressive Strength of Hydraulic Cement Mortars (Using 2-in. or [50 mm] Cube Specimens)
- .4 ASTM C139-17, Standard Specification for Concrete Masonry Units for Construction of Catch Basins and Manholes
- .5 ASTM C191-21, Standard Test Methods for Time of Setting of Hydraulic Cement by Vicat Needle
- .6 ASTM C478/C478M-22, Standard Specification for Circular Precast Reinforced Concrete Manhole Sections
- .7 ASTM C827/C827M-16, Standard Test Method for Change in Height at Early Ages of Cylindrical Specimens of Cementitious Mixtures
- .8 ASTM C882/C882M-20, Standard Test Method for Bond Strength of Epoxy-Resin Systems Used With Concrete By Slant Shear
- .9 ASTM C920-18, Standard Specification for Elastomeric Joint Sealants.
- .10 ASTM D698-00, Standard Test Methods for Laboratory Compaction Characteristics of Soil Using Standard Effort (12,400 ft-lbf/ft<sup>3</sup> (600 kN-m/m<sup>3</sup>)).
- .11 COE CRD C 588, 1997 Edition, Corps of Engineers Specification for Nonshrink Grout.
- .12 COE CRD C 621, 1998 Edition, Corps of Engineers Spec. for Non-Shrink Grout.

### **1.3 ACTION AND INFORMATIONAL SUBMITTALS**

- .1 Product data:
  - .1 Submit manufacturer's instructions, printed product literature and data sheets for manholes, catch basin, sluice boxes and valve chambers and include product characteristics, performance criteria, physical size, finish and limitations.
- .2 Shop Drawings: Refer to Section 01 00 00 – Project Specific General Requirements.

## **1.4 QUALITY ASSURANCE**

### **.1 Certifications:**

- .1 Submit manufacturer's test data and certification at least ten (10) working days prior to beginning work. Include manufacturer's drawings, information and shop drawings where pertinent.
- .2 Certificates: submit certificates signed by manufacturer certifying that materials comply with specified performance characteristics and physical properties.
- .3 Manufacturer's instructions: submit manufacturer's installation instructions and special handling criteria, installation sequence, cleaning procedures, etc.

## **1.5 DELIVERY, STORAGE AND HANDLING**

- .1 Deliver, store and handle materials in accordance with manufacturer's written instructions.
- .2 Delivery and Acceptance Requirements: deliver materials to site in original factory packaging, labelled with manufacturer's name and address.
- .3 Storage and handling requirements:
  - .1 Store materials in accordance with manufacturer's recommendations.
  - .2 Store and protect manholes, catch basins and valve chambers from nicks, scratches, and blemishes.
  - .3 Replace defective or damaged materials with new.

## **1.6 MEASUREMENT FOR PAYMENT**

- .1 Manholes, catch basins, sluice boxes and valve chambers will be measured for payment in units of each size installed. The unit price shall include all labour, materials and equipment necessary for the full completion of the work, including excavation, backfill, compaction, installation of the adjustable or standard frame, cover or grate, as well as other work described in this Specification.
- .2 Payment for adjustment of existing structures with adjustable frames and covers shall be made on a per unit basis. The price shall include all labour, materials and equipment, including asphalt placement underneath the flange of the inner frame, to adjust the structure to the required elevations.
- .3 Payment for adjustment of existing structures with standard frame and covers shall be on a unit basis. The price shall include all labour, materials and equipment, including asphalt required for padding around frame, to adjust structure to required elevations.
- .4 All structures other than new structures, shall be measured for adjustment, even when rebuilding must take place.
- .5 Payment for additional height for rebuilding structures with standard frames and covers shall be on a vertical lineal measurement basis. It shall be measured from the top of the undisturbed surface of the structure to the bottom of the frame less 100 mm. Payment for the top 100 mm is included in the unit price of adjustment.

- .6 The "collaring", permanent or temporary, of the adjusted standard frames and covers with asphalt concrete shall be considered incidental to the Contract and no additional payment shall be made for any labour, materials or equipment, including asphalt concrete. Asphalt thickness for this purpose shall be a minimum of 75 mm.
- .7 In high volume traffic areas, streets are to be returned to normal use after each day's work by the Contactor, as directed by the Owner or Consultant. Temporary asphalt concrete collaring of standard frames and covers for this purpose shall also be considered incidental to the Contract, as specified with respect to "collaring" above.

## 2 PRODUCTS

### 2.1 MATERIALS

- .1 **Precast manhole units:** to ASTM C 478M, circular:
  - .1 Top section flat slab top type with opening centered for sanitary manholes and opening offset for storm manholes.
  - .2 Intermediate sections to diameter specified and to the depth required.
  - .3 Base section to be precast concrete with reinforced concrete slabs within. Sanitary manhole bases to have cast in wedge-type gasket or approved equivalent to suit outside diameter (OD) of each inlet and outlet pipes. Any additional holes required in the field shall be core-drilled and a Kor-N-Seal connector inserted.
  - .4 Base sections for sanitary manholes to be pre-benched during manufacturing. Storm manholes to be inside flat bottom.
- .2 **Precast catch basin sections and sluice boxes:** to ASTM C139 and ASTM C478M:
  - .1 Catch basins to be type and size as indicated with precut holes of size to fit OD of inlets and outlets.
  - .2 Catch basin for single pipe outlet to be 750 mm diameter and top section, intermediate section to be all included in one piece.
  - .3 All catch basins shall have sumps provided in concrete bases and shall be 300 mm unless otherwise indicated.
  - .4 Sluice boxes with precut holes of sufficient size to suit the lateral.
- .3 **Precast valve chambers:** to ASTM C139 and ASTM C478M:
  - .1 Valve Chambers to be type and standard size of 1200 mm diameter unless otherwise indicated.
  - .2 Top section flat slab top type with opening centered for plumb vertical access to valve operating nut.
  - .3 Intermediate sections to diameter specified and to the depth required.
  - .4 Intermediate sections to be set on reinforced concrete pads. Size of pads to be 1524 mm x 406 mm x 203 mm unless oversize required for larger valve chambers.
- .4 **Joints between sections:** rubber gasket, Ram-Nek gasket and waterproofing membrane as

indicated on the detail drawings and to CSA A257.3.

- .1 Waterproofing membrane: Bakor Blueskin WP 200 c/w Aquatac Primer, Colphene 3000 by Soprema c/w Elastocol Stick Primer or approved equivalent.

.5 **Reinforced concrete grade rings:** to ASTM C478

- .1 Reinforced concrete grade adjustment rings shall be circular and be free from cracks, voids, and other defects.
- .2 Concrete grade adjustment rings shall have a minimum height of 100 mm, and an inside diameter of 600 mm, or 750 mm as specified.

.6 **Rubber adjustment rings:** Consist of no less than 80% by weight recycled rubber from tires and no less than 10% by volume shredded fibres.

- .1 Acceptable Products:
  - .1 FLEX O RING BE800 Series as manufactured by American Steel and Rubber
  - .2 Infra-Riser
  - .3 Ring-o-Riser as manufactured by RG2S Solutions
  - .4 Approved equivalent.

.7 **Mortar and grout:**

- .1 Mortar:
  - .1 Mortar to be quick set, high strength, non-shrink polymer modified Cementitious mortar meeting ASTM C109 for compressive strength. and C-78 for flexural strength and ASTM C882 for Slant Shear Bond Strength.
  - .2 Mortar shall not contain any chlorides, gypsums, plasters, iron particles, aluminum powder or gas-forming agents and shall not promote corrosion of any metal in contact with.
  - .3 Acceptable products:
    - .1 Octocrete by IPA Systems.
    - .2 Approved equivalent.
- .2 Grout:
  - .1 Grout to be a premixed, non-metallic, high strength, non-shrink grout which meets the requirements of ASTM C191 and ASTM C827 as well COE CRD C 588 and COE CRD C 621.
  - .2 Grout shall have a minimum one-day strength of 6000 psi (41 MPa) and a 28-day strength of 9000 psi (62 MPa).
  - .3 Acceptable Products:
    - .1 PennGrout by IPA Systems.
    - .2 Approved equivalent.

.8 **Adhesive/Sealant:**

- .1 Each grade ring and adjusting ring are to be made watertight with M-1 Structural adhesive/sealant between each ring.
- .2 Adhesive/Sealant to meet the following:
  - .1 ASTM C920, Type S, Grade NS, Class 25, Uses NT, T, M, G, A and O.

.9 Frames, gratings, covers to dimensions as indicated and following requirements:

.1 **On Streets Manhole/Valve Chamber Frames and Covers**

- .1 Adjustable manhole frames and covers shall meet the requirements of the latest ASTM A536 for ductile iron castings or ASTM A48, Class 30, for cast iron castings, and to be CSA approved.
- .2 Castings to be coated with two applications of asphalt varnish sand blasted or cleaned and ground to eliminate surface imperfections.
- .3 Manhole covers shall be complete with two 20 mm found lifting holes.
- .4 Manhole frames: Top of manhole guide frame to be set level to top of subgrade.
- .5 Frames and covers shall be resilient seated seat with conical guide.
- .6 Covers for manhole and gate valve to be 624 mm diameter and for air valve cover to be 775 mm diameter.
- .7 Gate Valve cover to have 125 mm center button for access to valve nut.

.2 **Off Streets Manhole/Valve Chamber Frames and Covers**

- .1 Standard manhole frames and covers shall meet the requirements of the latest ASTM A48, Class 30, for cast iron castings.
- .2 Castings to be coated with two applications of asphalt varnish sand blasted or cleaned and ground to eliminate surface imperfections.
- .3 Manhole covers shall be complete with two 20 mm found lifting holes.
- .4 Covers for manhole and gate valve to be 635 mm diameter and for air valve cover to be 749 mm diameter.
- .5 Gate Valve cover to have 125 mm center button for access to valve nut.

.3 **Catch Basin Frames and Grates**

- .1 Standard catch basin frames and grates shall meet the requirements of the latest ASTM A48, Class 30, for cast iron castings.
- .2 Castings to be coated with two applications of asphalt varnish sand blasted or cleaned and ground to eliminate surface imperfections.
- .3 Flat and pyramid style grates to be 610 mm square.

### **3 EXECUTION**

#### **3.1 EXAMINATION**

- .1 Verification of Conditions: verify that conditions of substrate previously installed under other Contracts are acceptable for manholes, valve chambers and catch basin structures installation in accordance with manufacturer's written instructions.
  - .1 Visually inspect substrate in presence of Owner or Consultant.
  - .2 Inform Owner or Consultant of unacceptable conditions immediately upon discovery.
  - .3 Proceed with installation only after unacceptable conditions have been remedied.

#### **3.2 EXCAVATION AND BACKFILL**

- .1 Excavate and backfill in accordance with Section 31 23 33.01 - Excavating Trenching and Backfilling and as indicated.
- .2 Obtain approval of Owner or Consultant before installing, manholes, valve chambers or catch basins.

#### **3.3 INSTALLATION**

- .1 Construct units in accordance with details indicated, plumb and true to alignment and grade.
- .2 Complete units as pipe laying progresses.
  - .1 Maximum of 3 units behind point of pipe laying will be allowed.
- .3 Dewater excavation to approval of Owner or Consultant and remove soft and foreign material before placing concrete base.
- .4 Precast units:
  - .1 Set bottom section of precast unit in 150 mm minimum of granular bedding compacted to 95% corrected maximum dry density or maximum density to ASTM D698.
  - .2 Make each successive joint watertight with approved single offset gaskets, O-ring gasket, bituminous compound, or combination of these materials.
  - .3 Plug lifting holes with cement mortar or grout.
- .5 Cast-in-place units:
  - .1 Set cast-in concrete base on 150 mm minimum of granular bedding compacted to 95% corrected maximum dry density or maximum density to ASTM D698.
  - .2 For sanitary sewers, bench to provide smooth U-shaped channel. Side height of channel to be full diameter of sewer. Slope adjacent floor at 1 in 20. Curve channels smoothly. Slope invert to establish sewer grade.
  - .3 Clean surplus mortar and joint compounds from interior surface of unit as work

progresses.

- .6 Compact granular backfill to 95% corrected maximum dry density or maximum density to ASTM D698.
- .7 Place frame and cover on top section to elevation as indicated.
  - .1 All manholes, valve chambers and catch basins to have a minimum of 100 mm and maximum of 300 mm in adjustment rings.
  - .2 If the flat top of the manhole, valve chamber or catch basin is not level or irregular, a mortar/grout bed is to be used to make level before placement of the first grade ring.
  - .3 The first grade ring is to be embedded in the mortar/grout bed before setting and level. If no mortar/grout is required, the first grade ring and all other rings are to be set with adhesive/sealant.
- .8 Clean units of debris and foreign materials.
  - .1 Remove fins and sharp projections.
  - .2 Prevent debris from entering system.
  - .3 Remove lifting devices and grout opening.

### **3.4 ADJUSTING TOPS OF EXISTING UNITS**

- .1 Remove existing frames, covers and grates and store for re-use at locations designated by Owner or Consultant.
- .2 Sectional units:
  - .1 Raise or lower straight walled sectional units by adding or removing precast sections as required.
  - .2 When amount of raise is less than 600 mm use grade rings, adjustment rings, mortar/grout and adhesive/sealant specified under section 2.1.
- .3 Re-use existing frames covers and gratings upon approval of Owner or Consultant.

**END OF SECTION**

## **1 GENERAL**

### **1.1 DESCRIPTION**

- .1 This Section specifies the requirements for supplying and installing various diameters water main, water services and fittings. Work includes excavation, supply and installation of pipe, fittings, valves, restraints and cathodic protection, bedding materials, backfill, compaction and testing of pipe as shown on the associated drawings.

### **1.2 REFERENCE STANDARDS**

- .1 ANSI/AWWA C104/A21.4-16, Cement Mortar Lining for Ductile-Iron Pipe and Fittings for Water.
- .2 ANSI/AWWA C105/A21.5-18, Polyethylene Encasement for Ductile-Iron Pipe Systems.
- .3 ANSI/AWWA C110/A21.10-21, Ductile-Iron and Gray-Iron Fittings.
- .4 ANSI/AWWA C111/A21.11-17, Rubber-Gasket Joints for Ductile-Iron Pressure Pipe Fittings.
- .5 ANSI/AWWA C151/A21.51-17, Ductile-Iron Pipe, Centrifugally Cast, for Water.
- .6 ANSI/AWWA C153/A21.53-19, Ductile-Iron Compact Fittings.
- .7 ANSI/AWWA C205-18, Cement-Mortar Protective Lining and Coating for Steel Water Pipe, 4 In. (100 mm) and Larger, Shop Applied.
- .8 ANSI/AWWA C208-17, Dimensions for Fabricated Steel Water Pipe Fittings.
- .9 ANSI/AWWA C502-18, Dry-Barrel Fire Hydrants.
- .10 ANSI/AWWA C509-15, Resilient-Seated Gate Valves for Water-Supply Service.
- .11 ANSI/AWWA C515, Underground Service Line Valves and Fittings.
- .12 ANSI/AWWA C600-17, Installation of Ductile-Iron Water Mains and Their Appurtenances.
- .13 ANSI/AWWA C651-14, Disinfecting Water Mains.
- .14 ANSI/AWWA C900-22, Polyvinyl Chloride (PVC) Pressure Pipe and Fabricated Fittings, 4 In. Through 60 In. (100 mm Through 1,500 mm).
- .15 ANSI/AWWA C905-01(2012), Standard Test Methods for Apparent Density of Chemical-Resistant Mortars, Grouts, Monolithic Surfacing, and Polymer Concretes
- .16 ANSI/AWWA C909-22, Molecularly Oriented Polyvinyl Chloride (PVCO) Pressure Pipe, 4 In. (100 mm) and Larger.
- .17 ASTM B88M-20, Standard Specification for Seamless Copper Water Tube (Metric).
- .18 ASTM A307-21, Standard Specification for Carbon Steel Bolts, Studs, and Threaded Rod 60 000 PSI Tensile Strength.
- .19 ASTM F1674-18, Standard Test Method for Joint Restraint Products for Use with PVC Pipe.
- .20 ASTM C94/C94M-22a, Standard Specification for Ready-Mixed Concrete.

- .21 ASTM D698-00, Standard Test Methods for Laboratory Compaction Characteristics of Soil Using Standard Effort (12,400 ft-lbf/ft<sup>3</sup> (600 kN-m/m<sup>3</sup>)).
- .22 AWWA M17, M17: Fire Hydrants: Installation, Field Testing, and Maintenance, 2016.
- .23 CSA-A23.1:19/A23.2:19, Concrete Materials and Methods of Concrete Construction/Test Methods and Standard Practices for Concrete.

### **1.3 ACTION AND INFORMATIONAL SUBMITTALS**

- .1 Product data:
  - .1 All materials and equipment installed that come into contact with potable water must meet the safety criteria and certification of NSF/ANSI Standard 61: Drinking Water System Components.
  - .2 At least 2 weeks prior to commencing work, submit manufacturer's test data and certification that pipe materials meet the requirements of this section. Include manufacturer's drawings, information and shop drawings where pertinent.
- .2 Shop Drawings:
  - .1 Submit shop drawings for gate valves, air release valves, fire hydrants, chambers and any special fittings.

### **1.4 SCHEDULE OF WORK**

- .1 Scheduling:
  - .1 Schedule Work to minimize interruptions to existing services.
  - .2 Submit schedule of expected interruptions for approval to the Owner or Consultant and adhere to interruption schedule as approved by Owner or Consultant.
  - .3 Notify Owner or Consultant minimum of 48 hours in advance of interruption in service.
  - .4 Do not interrupt water service for more than 8 hours and confine this period between 9:00am and 6:00pm local time unless otherwise authorized.
  - .5 Notify fire department of planned or accidental interruption of water supply to hydrants.
  - .6 Supply and post "Out of Service" sign on hydrant not in use.
  - .7 Advise local police department of anticipated interference with movement of traffic.
  - .8 Under no circumstances whatsoever shall the contractor operate existing water main valves, fire hydrants, or make connections to existing water mains without the prior approval of the owner.

### **1.5 DELIVERY, STORAGE AND HANDLING**

- .1 Deliver, store and handle materials in accordance with manufacturer's written instructions.

- .2 Delivery and acceptance requirements: deliver materials to Site in original factory packaging, labelled with manufacturer's name and address.
- .3 Storage and handling requirements:
  - .1 Store materials off ground and in accordance with manufacturer's recommendations in clean, dry, well-ventilated area.
  - .2 Store and protect water distribution piping from nicks, scratches, and blemishes.
  - .3 Replace defective or damaged materials with new.
  - .4 All water distribution piping ends to be covered (capped) until ready for installation.

## 1.6 MEASUREMENT FOR PAYMENT

### .1 Pipe, Joints and Fittings:

- .1 Payment of watermain pipe and water service laterals shall be per linear metre (m) of completed pipe. The measurement of completed watermain and water service laterals shall include the supply of all labour, materials and equipment for excavation, disposal of unsuitable or surplus excavated material, shoring, dewatering, bedding, supply & installation of pipe, polyethylene encasement, backfilling, compaction, testing of pipe and all incidental items.
- .2 The length of installed water main pipe shall be measured horizontally with no deduction for valves or fittings.
- .3 Water service laterals shall be measured in metres (m) from the centre of the water main at the connection to the end of the lateral including the distance through the goose neck.
- .4 Measurement for payment for fittings such as bends, tees, caps, couplings, etc. shall be based on each unit, including all labour, materials and equipment required to properly supply and install these units. Payment shall include supply, excavation, dewatering, bedding, installation, thrust blocks, backfilling, plus all other incidental items.
- .5 Supply and installation of tracer wire is incidental and shall be considered as included in the unit price for the item requiring tracer wire.
- .6 All labour, materials and equipment for the installation of corporation stops, saddles, anodes and flushings for testing and chlorinating as shown on the Contract Drawings shall be included in the Contract Unit Price of the pipe. If the initial bacteriological test fails, the Town shall re-flush and clean the watermain in accordance with the latest AWWA C651 Standard. The Contractor shall pay for the re-flushing, cleaning, re-chlorinating, re-testing and any other associated costs. There will be no compensation for delays due to this testing procedure. Disinfection procedures when cutting into and connecting to existing watermains shall be considered as incidental to the Schedule of Quantities and Unit Prices, Section 00 41 43.01.
- .7 There shall be no separate measurement for payment for thrust blocks. Include costs in items requiring thrust blocks with such items as bends, tees, caps, etc.
- .8 There shall be no separate measurement for payment for restrainers. Include costs in items requiring restrainers with such items as valves, bends, tees, reducers, caps, etc.

- .9 Pipe insulation shall be measured in square metres (m<sup>2</sup>) of insulation placed and to be based on 50 mm thickness.
- .10 Removal and off-site disposal of existing watermain and fittings outside of the normal trench excavation shall be measured for payment at the unit prices for common excavation and backfill. Payment shall include excavation, removal, off-site disposal and backfilling of trench.
- .11 Payment for bell and spigot restrainers shall be based on each bell and spigot restrainer unit and shall include all items required to restrain a complete bell and spigot joint.
- .2 Valves and Valve Boxes:**
- .1 Measurement for payment for valves, valve boxes, bends, tees, hydrants, curb stops, corporation main stops complete with saddles, anodes, etc. shall be based on each unit, including all labour, materials and equipment required to properly supply and install these units. Payment shall include supply, excavation, dewatering, bedding, installation, thrust blocks, backfilling, plus all other incidental items.
- .2 Service boxes, including supply and installation, excavation and backfilling, will be measured in units of each size installed.
- .3 Service box and/or curb stop renewals where existing water service lateral piping does not require renewal shall be measured for payment on a per unit basis including all excavation, backfilling, connections to existing and incidentals.
- .4 Location and adjustment of existing valve boxes shall be measured in units adjusted.
- .5 Valve chambers including supply and installation of the structure, excavation and backfilling, will be measured in units installed as per the associated drawings.
- .3 Fire Hydrants:**
- .1 Payment of fire hydrants shall be considered as all the material and labour necessary to supply and install the hydrant including the 150 mm gate valve, 130 mm valve box, the restraints, anchor tee, vertical piping and thrust blocks.
- .2 Payment shall include connecting the hydrant to the gate valve, the gate valve to the hydrant anchor tee, excavation and backfilling, polyethylene encasement of the vertical hydrant piping, and all incidental items.
- .3 Payment for the supply and installation of a hydrant extension, where required, will be on a per unit basis. Payment for the horizontal hydrant lead shall be made as watermain pipe.
- .4 Air Release Valves and Chambers:**
- .1 Measurement for payment for air valves shall be on a per unit basis for each complete valve installed including corporation main stops, saddles, nipples, etc., connection to watermain, chamber, insulation of chamber, complete with vent pipe assembly, as per the Standard Drawing.
- .2 Valve chambers including supply and installation of the structure, excavation and backfilling, will be measured in units installed as per the details.
- .3 Location and adjustment of existing air release valve boxes and air release valve chambers shall be measured in units adjusted.

.5 **Anode Corrosion Protection:**

- .1 Payment for the supply and installation of zinc anodes, where required, will be on a per unit basis for each size indicated.

**2 PRODUCTS**

**2.1 PIPE, JOINTS AND FITTINGS**

.1 **PVC Pipe:**

- .1 Molecularly Oriented Polyvinyl Chloride (PVCO): to ANSI/AWWA C909, pressure class 235, produced with cast iron outside diameter in sizes 100 mm to 450 mm, colour coded blue.
- .2 Polyvinyl chloride pressure pipe: to ANSI/AWWA C900, pressure class 150, DR 18, produced with cast iron outside diameter in sizes 100 mm to 300 mm, colour coded blue.
- .3 Polyvinyl chloride pressure pipe: to ANSI/AWWA C905, class 235, DR 18, cast iron outside diameter in sizes 350 mm to 900 mm, colour coded blue.
- .4 Joints to be bell and spigot type with integral rubber gasket. This is a push-on joint and must be watertight. The bell will be an integral and homogenous part of the pipe barrel.

.2 **Ductile Iron Pipe:**

- .1 Ductile iron pipe: to ANSI/AWWA C151/A21.51, pressure class 350 for cement mortar lined to ANSI/AWWA C104/A21.4 in all sizes.
- .2 All ductile iron in buried installation shall be polyethylene encased (wrapped) meeting the requirements of latest AWWA C105.
- .3 Ductile iron pipe for flanged ends: to ANSI/AWWA C151/A21.51, special class 54 for cement mortar lined to ANSI/AWWA C104/A21.4 in all sizes. Flanged pipe not to be used in buried applications.
- .4 Joints for ductile iron pipe will be push-on rubber gasket type meeting the requirements of the latest AWWA C111 for rubber gasket joints for ductile iron pressure pipe.

.3 **Fittings and Couplings:**

- .1 Ductile iron fittings: to ANSI/AWWA C208, cement mortar lined to ANSI/AWWA C205, and exterior protected with epoxy coated complete with steel bolts and nuts. Fittings to include tees, crosses, bends, and caps and couplings.
- .2 PVC pressure fittings shall be the push-on bell and spigot type and meet the requirements of AWWA C907 and CSA B137.2.
- .3 Joints for ductile iron fittings will be a mechanical type meeting the requirements of ANSI/AWWA C110/A21.10. for rubber gasket joints for ductile-iron pressure pipe. Fittings will be complete with component parts.
- .4 All iron fittings and fire hydrants shall be corrosion resistant, ductile-iron epoxy coated

with steel tee bolts and nuts.

- .5 Hydrant anchor tees: to be mechanical joint swivel, ductile iron class 350 as per ANSI/AWWA C153/A21.53.
  - .1 Acceptable products for hydrant anchor tee:
    - .1 Bibby Ste. Croix.
    - .2 Sigma.
    - .3 Star Pipe Products.
    - .4 Approved equivalent
- .6 In all cases where full mechanical joint gray-iron or ductile iron couplings combined with mechanical joint restraints can be used, they are to be the preferred coupling system.
- .7 If sleeve style coupling is required, acceptable coupling will require Owner or Consultant approval before use.

## 2.2 VALVES AND VALVE BOXES

### .1 **Gate Valves:**

- .1 Gate valves to open counterclockwise.
- .2 Gate valves to be complete with steel tee bolts and nuts and a 50 mm square operating nut.
- .3 Gate Valves are to be used in all valves up to and including 300 mm diameter. Valves for sizes greater than 300 mm are to be determined at time of design.
- .4 All gate valves to be Factory Mutual (FM) approved and ULC listed.
- .5 Gate valves: to be resilient seated conforming to ANSI/AWWA C509 or C515, epoxy coated interior and exterior, standard cast iron body, brass mounted wedge valves encapsulated with rubber, non-rising stems, suitable for 1 Pa with mechanical joints.
  - .1 Acceptable products for gate valves are as follows:
    - .1 Clow Model 2639/2640.
    - .2 Mueller Model 2361.
    - .3 Approved equivalent.

### .2 **Air and vacuum release valves:**

- .1 Heavy duty combination air release valves employing direct acting kinetic principle.
- .2 Fabricate valves of cast iron body and cover, with bronze trim, stainless steel floats with shock-proof synthetic seat suitable for 1034 kPa working pressure.
- .3 Valves to expel air at high rate during filling, at low rate during operation, and to admit air while line is being drained.
- .4 Valves to be complete with surge check unit and unless otherwise specified, inlet shall be 50 mm (large) and outlet 2.3 mm (Small).
- .5 Refer to standard detailed drawing for connection to pipe by saddle, corporation stop

for isolation, venting and chamber.

- .6 All air and vacuum release valves to be 50 mm unless otherwise noted.
- .7 Acceptable products for air and vacuum release valves are as follows:
  - .1 Apco Valve Model 145C.
  - .2 Val-Matic Model 202C.2.
  - .3 Crispin Valve UL Series Model UL20.
  - .4 Vent-O-Mat Model 050 RBX 2521.
  - .5 Approved equivalent.

**.3 Valve boxes:**

- .1 Size of box to be 130 mm.
- .2 Mueller MVB composite valve box or approved equal to be complete with 686mm ductile-iron adjustable top, cast iron cover and guide plate.
- .3 Adjustable tops must be bevelled edge type.
- .4 Acceptable products for valve boxes are as follows:
  - .1 Mueller Canada.
  - .2 Approved equivalent.

**2.3 SERVICE CONNECTIONS**

- .1 Service lateral piping shall be minimum 25mm diameter copper tubing, Type K to ASTM B88 or minimum 25mm cross-linked polyethylene (PEX-A) pipe to CSA B137.5 complete with stainless steel liners at connections.
- .2 All residential single-family homes to be 25 mm diameter. For services greater than 50 mm, pipe to be as per section 2.01.
- .3 Brass corporation stops:
  - .1 Outlet connection having compression type and inlet having standard corporation threads to ANSI/AWWA C800.
    - .1 Acceptable products for brass corporation stops are as follows:
      - .1 Bibby Ste-Croix.
      - .2 Mueller Canada.
      - .3 Star Pipe Canada.
      - .4 Approved equivalent.
- .4 Brass curb stops:
  - .1 Compression type without drains.
  - .2 Curb stops to have 105 mm diameter service box complete with bevelled edge adjustable top located at the street/property line.
    - .1 Acceptable products for brass curb stops are as follows:

- .1 A.Y. MacDonald Mfg. Co.
- .2 Mueller Canada Series B25209.
- .3 Cambridge Brass, Model No. 202.
- .4 Ford Meter Box Company, Inc.
- .5 Approved equivalent.

**.5 Service Saddles:**

- .1 Service saddles for Molecularly Oriented Polyvinyl Chloride (PVCO) or PVC DR18 pipe:
  - .1 Service connections for 50 mm or less: require corporation stop, connected to main complete with full body single piece bronze service saddle.
  - .2 Service saddle to consist of full body circumferential band type complete with side bars and fingers, keeper bar, stud bolts, nuts, washers and gaskets.
  - .3 Saddle to be fully passivated for corrosion protection.
  - .4 Saddle to be cast bronze body supplied with nitrile rubber gasket and have a minimum working pressure of 1034 kpa.
  - .5 Acceptable products for service saddles connected to Molecularly Oriented Polyvinyl Chloride (PVCO) pipe 100 mm to 300 mm:
    - .1 Robar model 2706.
    - .2 Romac 202BS
    - .3 Ford FC202BSD
    - .4 Approved equivalent.
- .2 Service connections greater than 50mm: Use tee fitting and gate valve or tapping valve and sleeve.

**2.4 FIRE HYDRANTS**

- .1 Fire Hydrants: Compression type hydrant complete with safety flange, to CAN/ULC-S520, designed for minimum working pressure of 1034 kPa with two 65 mm threaded hose outlets, one 100 mm threaded pumper connection, 150 mm riser barrel, 125 mm bottom valve and 150 mm connection for main.
  - .1 Fire Hydrants to open counterclockwise, threads to local standard, fittings to be internal lug quick-connect to CAN/ULC-S543. Provide metal caps and chains.
  - .2 Provide key operated gate valve open counterclockwise located at hydrant anchor tee.
  - .3 Depth of bury 1.95 m unless otherwise greater in specified design.
  - .4 Fire Hydrants and connections shall be in accordance with the latest AWWA C502, ULC and FM Standards.
  - .5 Drain holes in the fire hydrant boot shall be permanently plugged internally.
  - .6 Acceptable products for Fire Hydrants:

- .1 Canada Valve Century.
- .2 Clow Brigadier M-67.
- .3 Mueller Modern Centurion.
- .4 Approved equivalent.

## 2.5 TAPPING SLEEVES

- .1 Tapping sleeves to be 100% stainless steel with full seals around the circumference of the pipe. Tapping sleeves to be Mueller or approved equal.
- .2 Tapping valves shall be resilient seat type, meeting the requirements of AWWA C509 or AWWA C515 for gate valves.

## 2.6 PIPE RESTRAINTS FOR MECHANICAL JOINTS AND THRUST BLOCKS

- .1 Pipe restraints: Pipe restraints to be used on all mechanical joints:
  - .1 Pipe restraints to be used in combination with thrust blocks on all tees, crosses, bends, couplings, caps, fire hydrants, etc.:
    - .1 Pipe restraints to be cast iron supplied with fusion-bonded epoxy and have a minimum working pressure of 1034 kPa.
    - .2 Pipe restraints shall be in accordance with latest addition of ASTM F1674.
  - .2 Pipe restraints acceptable products for PVC pipe:
    - .1 Clow TUFGRIP Dual Wedge Restraint (Universal).
    - .2 Approved equivalent.
  - .3 Pipe restraints acceptable products for PVC DR18 pipe:
    - .1 Clow 300 C restrainer.
    - .2 EBAA IRON Series 2000 PV.
    - .3 Uni-Flange Series 1300/1500.
    - .4 Sigma One-Lok SLC Series.
    - .5 Star Pipe Products PVC Stargrip Series 4000.
    - .6 Star Pipe Products PVC Ring Lock Series 3500.
    - .7 Clow TUFGRIP Dual Wedge Restraint (Universal).
    - .8 Approved equivalent.
  - .4 Pipe restraints acceptable products for ductile iron pipe:
    - .1 EBAA IRON Series 1100.
    - .2 Romac Industries RomaGrip.
    - .3 Sigma One-Lok SLD Series.
    - .4 Star Pipe Products PVC Stargrip Series 3000.
    - .5 Clow TUFGRIP Dual Wedge Restraint (Universal).

.6 Approved equivalent.

.2 Concrete thrust block:

- .1 Cast-in-place thrust blocks shall be installed on all tees, bends, crosses, caps, fire hydrants, etc.
- .2 Thrust block design and dimensions shall be as shown on the Drawings.
- .3 All thrust blocks shall bear against undisturbed soil.
- .4 All concrete used for thrust blocks shall be ready-mix concrete from supplier certified under ASTM C94 and CSA-A23.1.
- .5 Concrete used for thrust blocks to be 32 Mpa at 28 days.
- .6 Prior to pouring concrete thrust block, place 8 mil poly barrier around fitting. Fitting bolts, nuts and washers to be accessible after the thrust block has been poured.

## 2.7 CATHODIC PROTECTION

- .1 Provide means of protection for ductile iron pipe with 8-mil poly wrap in accordance with ANSI/AWWA C105/A21.5.
- .2 Criteria for corrosion protection shall meet or exceed NACE RP0169.
- .3 Anode Corrosion Protection:
  - .1 All mechanical joint fittings including tees, crosses, bends, couplings, caps and valves 200 mm diameter or less to be protected with 5.5 kg zinc anode.
  - .2 All hydrants, corporation stop, curb stop, copper service longer than 20 meters and tees, crosses, bends, caps and valves greater than 200 mm but less than 350 mm to be protected with 11 kg zinc anode.
  - .3 Acceptable products for zinc anode suppliers are:
    - .1 Interprovincial Corrosion Control.
    - .2 Corrosion Services.
    - .3 Exothermal Industries.
    - .4 Integrity Anode Corporation.
    - .5 Bren Technologies Inc.
  - .4 Anodes shall be installed by wrapping around bolts and securing with a second nut.
  - .5 Anti-corrosion petrolatum paste, mastic and tape:
    - .1 Shall be applied on all fittings greater than 300 mm.
    - .2 Prior to applying the paste, surface of fittings to be free of loose coating, rust soil, and any other foreign matter.
    - .3 Technique for applying paste, mastic and wrap is to be followed as per manufacture specifications.

.4 Acceptable products for petrolatum paste, mastic and tape systems are as follows:

- .1 Petro Coating Systems.
- .2 PetroWrap.
- .3 STAC.
- .4 Trenton.
- .5 Denso.
- .6 PetroGuard.
- .7 Approved equivalent.

## 2.8 INSULATION

.1 Extruded polystyrene foam insulation board for watermains and service laterals is to be used when depth of cover of 1.8 m cannot be achieved and when crossing under or over storm sewers. Acceptable products for foam board insulation are as follows:

- .1 Styrofoam HI 40.
- .2 Foamular 400.
- .3 Approved equivalent.

.2 Curved insulation to be used on valve chambers, combination air valve chambers and other specified locations as directed by Owner or Consultant.

- .1 Expanded polystyrene insulation with woven white polypropylene radiant blocker facing, laminated both sides of core.
- .2 White Laminated facing to be treated for acid and UV resistance.
- .3 Board to have a bursting strength of 172 lbs/sq. inch.
- .4 The facing shall extend beyond the edge forming a self-adhesive overlap flap.
- .5 Acceptable products for curved insulation board are as follows:
  - .1 Alleguard SilverBoard 25 (SB25HD)
  - .2 Approved equivalent.

## 2.9 TRACER WIRE

.1 Tracer wire will be required on all PVC and PVCO main line distribution pipe and PVC and PVCO fire hydrant leads.

.2 Tracer wire shall be RWU90, 10-gauge (AWG), single strand, insulated copper wire with cross-linked polyethylene (XLPE) insulation, specifically manufactured for direct bury applications.

.3 All spliced or repaired wire connections in the tracer wire system shall be made using appropriate connectors. Acceptable products for connectors are as follows:

- .1 DryConn Direct Bury Lug-Aqua connectors.
- .2 Approved equivalent.

- .4 All bare ends of tracer wire connections to be enclosed and waterproofed. Acceptable products for connector ends are as follows:
  - .1 DryConn King 6 Blue connectors.
  - .2 Approved equivalent.
  
- .5 Tracer wire shall be attached to the top of the pipe at every fitting, valve and at intervals not exceeding 1.0 m using 50 mm wide tape. Tape shall also be used to attached tracer wire to valve boxes. Acceptable products for tape are as follows:
  - .1 T-Tape Gray PE, by Tapecoat.
  - .2 Approved equivalent.

## **2.10 PIPE BEDDING AND SURROUND MATERIALS**

- .1 Pipe bedding and surround material to Section 31 05 16 - Aggregate Materials and following requirements:
  - .1 Crushed or screened stone.

## **2.11 BACKFILL MATERIAL**

- .1 Selected backfill in accordance with Section 31 23 33.01 - Excavating, Trenching and Backfilling and subbase and base in accordance with Section 31 24 13 – Roadway Construction, Embankments and Compaction.
- .2 Unshrinkable fill: to Section 31 23 33.01 - Excavating, Trenching and Backfilling.

## **3 EXECUTION**

### **3.1 EXAMINATION**

- .1 Verification of conditions: verify that conditions of substrate previously installed under other sections or contracts are acceptable for distribution piping installation in accordance with manufacturer's written instructions:
  - .1 Visually inspect substrate in presence of Owner or Consultant.
  - .2 Inform Owner or Consultant of unacceptable conditions immediately upon discovery.
  - .3 Proceed with installation only after unacceptable conditions have been remedied.

### **3.2 PREPARATION**

- .1 Clean pipes, fittings, valves, hydrants, and appurtenances of accumulated debris and water before installation:
  - .1 Inspect materials for defects for approval of Owner or Consultant.
  - .2 Remove defective materials from Site as directed by Owner or Consultant.

### **3.3 TRENCHING**

- .1 Do trenching work in accordance with Section 31 23 33.01 - Excavating, Trenching and Backfilling.
- .2 Ensure trench depth allows coverage over pipe of 1.8 m minimum from finished grade.
- .3 Trench alignment and depth require Owner or Consultant approval prior to placing bedding material and pipe.

### **3.4 GRANULAR BEDDING**

- .1 Place granular bedding material in uniform layers not exceeding 150 mm compacted thickness to depth of 150 mm below invert of pipe.
- .2 Do not place material in frozen condition.
- .3 Shape bed true to grade to provide continuous uniform bearing surface for pipe.
- .4 Shape transverse depressions in bedding as required to suit joints.
- .5 Grade each layer full width of bed to prior to placement of next layer.
- .6 Fill authorized or unauthorized excavation below design elevation of bottom of specified bedding in accordance with Section 31 23 33.01 - Excavating, Trenching and Backfilling with compacted pit run gravel or approved equivalent.

### **3.5 BACKFILL**

- .1 Place selected backfill, subbase and base materials, above pipe bedding, in uniform layers not exceeding 150 mm compacted thickness up to grades as indicated.
- .2 Do not place backfill materials in frozen condition.
- .3 Under roadways and sidewalks, compact backfill to at least 95% corrected maximum dry density 95% maximum density to ASTM D698:
- .4 In other areas, compact to at least 90% corrected maximum dry density 90% maximum density to ASTM D698.

### **3.6 PIPE INSTALLATION**

- .1 Lay ductile iron pipes to ANSI/AWWA C600 and PVC/PVCO to manufacturer's standard instructions and specifications:
  - .1 Do not use blocks except as specified.
- .2 Join ductile iron pipes in accordance with ANSI/AWWA C600 and PVC/PVCO in accordance with manufacturer's recommendations.
- .3 Bevel or taper ends of PVC/PVCO pipe to match fittings.
- .4 Handle pipe by methods approved by Owner or Consultant and recommended by pipe manufacturer. Chains or cables are not to be passed through pipe bore for lifting.

- .5 Lay pipes on prepared bed, true to line and grade:
  - .1 Ensure barrel of each pipe is in contact with shaped bed throughout its full length.
  - .2 Remove and replace defective pipe.
  - .3 Correct pipe which is not in true alignment or grade or pipe which shows differential settlement after installation greater than 10 mm in 3 m.
- .6 Face bell ends of pipe in direction of laying and up-grade.
- .7 Do not exceed permissible deflection at joints as recommended by pipe manufacturer.
- .8 Keep jointing materials and installed pipe free of dirt and water and other foreign materials:
  - .1 Whenever work is stopped, install a removable watertight bulkhead/cap at open end of last pipe laid to prevent entry of foreign materials.
- .9 Position and join pipes with equipment and methods approved by Owner or Consultant.
- .10 Cut pipes in approved manner as recommended by pipe manufacturer, without damaging pipe or its coating and to leave smooth end at right angles to axis of pipe.
- .11 Align pipes before jointing.
- .12 Install gaskets to manufacturer's recommendations. Support pipes with hand slings or crane as required to minimize lateral pressure on gasket and maintain concentricity until gasket is properly positioned.
- .13 Avoid displacing gasket or contaminating with dirt or other foreign material:
  - .1 Remove disturbed or contaminated gaskets.
  - .2 Clean, lubricate and replace before jointing is attempted again.
- .14 Complete each joint before laying next length of pipe.
- .15 Minimize deflection after joint has been made.
- .16 Apply sufficient pressure in making joints to ensure that joint is completed to manufacturer's recommendations.
- .17 Ensure completed joints are restrained by compacting bedding material alongside and over installed pipes or as otherwise approved by Owner or Consultant.
- .18 When stoppage of work occurs, cap and block pipes in an approved manner to prevent creep during down time.
- .19 Recheck plastic pipe joints assembled above ground after placing in trench to ensure that no movement of joint has taken place.
- .20 Do not lay pipe on frozen bedding.
- .21 Do hydrostatic and leakage test and have results approved by Owner or Consultant before surrounding and covering joints and fittings with granular material.
- .22 Backfill remainder of trench.

### **3.7 TRACER WIRE INSTALLATION**

- .1 Tracer wire shall be installed on all non-ductile iron watermains, hydrant piping and water services. The wire shall be installed in such a manner as to be able to properly trace all watermains, hydrant laterals and water services without loss or deterioration of signal or without the signal migrating off the tracer wire. Refer to Standard Drawing 33.SD08
- .2 At the point of connection between the cast or ductile iron watermains, and any non-iron watermain, the tracer wire shall be connected to the first new valve box, or valve chamber, or as directed by the Owner or Consultant.
- .3 Tracer wire shall be laid flat and securely affixed to each fitting, valve, and top of the pipe at 1.0 m intervals, and to valve boxes and chambers using 50 mm wide T-Tape. Each piece of T-Tape shall be a minimum of 50 mm x 150 mm. Pipe shall be dry and cleaned of all dirt or dust where tape is to be applied.
- .4 The wire shall be protected from damage during the excavation or backfilling of the Works. No breaks or cuts in the tracer wire or tracer wire insulation shall be permitted. At water service saddles, the tracer wire shall not be allowed to be placed between the saddle and the watermain.
- .5 Except for approved spliced connections, tracer wire shall be continuous and without splices from valve to valve, valve box to hydrant, service box to watermain and house shut off to service box.
- .6 Prior to cutting the tracer wire for connections, the tracing wire shall be loose and not taut to avoid stretching. The tracing wire shall be stripped the length required for the electrical connector using an appropriate wire-stripping tool. The exposed copper wire shall be free of nicks or scores. Wire ends that will be used for connecting the tracing device shall be stripped of insulation and have waterproof caps installed.
- .7 An approved electrical connector shall be placed over the exposed area of the main tracer wire. The connecting tracer wire shall be carefully inserted into the connector up to the insulation. The connection shall be tightened and the waterproof covers sealed shut. Connections shall be snug and free from exposed copper.
- .8 Continuity tests shall be conducted by the Contractor. Testing shall be done in the presence of and to the satisfaction of the Owner and Consultant. Tracing wire installations that fail the continuity testing shall be corrected and retested to the satisfaction of the Owner and Consultant. The Contractor shall provide the Owner and Consultant with sufficient notification of any testing.

### **3.8 VALVE INSTALLATION**

- .1 Install valves to manufacturer's recommendations at locations as indicated.
- .2 Support valves located in valve boxes or valve chambers by means of concrete located between valve and solid ground. Bedding same as adjacent pipe. Maximum length of pipe on each end of valve shall be 1 m. Valves not to be supported by pipe.

### **3.9 VALVE CHAMBERS**

- .1 Use precast units as approved by Owner or Consultant.
- .2 Construct units as indicated, plumb and centred over valve nut, true to alignment and

- grade, and not resting on pipe.
- .3 Set precast concrete slab on 150 mm minimum of compacted granular bedding.
  - .4 Make each successive joint watertight with approved rubber ring gaskets, mastic joint filler, cement mortar, or combination thereof.
  - .5 Plug lifting holes with cement mortar.
  - .6 Set flat top cover with 600 mm diameter centre hole.
  - .7 Set frame and cover to required elevation with a minimum 100mm grade ring and a maximum of 300 mm.
  - .8 Place frame and cover on top section to elevation indicated.
  - .9 Clean valve chambers of debris and foreign materials; remove fins and sharp projections.

### 3.10 SERVICE CONNECTIONS

- .1 Terminate water service at property line opposite point of connection to main:
  - .1 Install curb stop, 300 mm of service pipe and coupling necessary for connection to building plumbing.
  - .2 If plumbing is already installed, make connection, otherwise cap or seal end of pipe and place temporary marker (38 x 89 stud from invert of pipe to 600 mm above finished grade in grassed areas and 600 mm below finished grade in asphalt areas) to locate pipe end. Paint exposed portion of stud blue with designation "WATER SERVICE LINE" in black.
- .2 Construct service connections at right angles to water main unless otherwise directed. Locate curb stops 300 mm inside right-of-way.
- .3 Tap main at 2:00 o'clock or 10:00 o'clock position only; not closer to joint nor closer to adjacent service connections than recommended by manufacturer, or 1 m minimum, whichever is greater
- .4 Employ only competent personnel equipped with suitable tools to carry out tapping of mains.
- .5 Direct tapping on PVC, PVCO or DI is not permitted. All tappings of water mains shall be done with approved saddles as indicated in Section 2.04.
- .6 In order to relieve strain on connections, install service pipe in "Goose Neck" form "laid over" into horizontal position.
- .7 New water service connections shall be one continuous length of water service piping from corporation stop to curb stop.
- .8 Leave corporation stop valves fully open.
- .9 Install curb stop with valve box on services 50 mm or less in diameter:
  - .1 Equip larger services with gate valve and valve box.
  - .2 Set box plumb over stop and adjust top flush with final grade elevation.
  - .3 Leave curb stop valves fully closed.

- .10 Do not install final service connections until satisfactory completion of hydrostatic and leakage tests of water main.

### **3.11 FIRE HYDRANTS**

- .1 Install fire hydrants at locations as indicated.
- .2 Install fire hydrants in accordance with AWWA M17.
- .3 Install 150 mm gate valve and bevelled top valve box on fire hydrant service leads as indicated.
- .4 Set fire hydrants plumb, with hose outlets parallel with edge of pavement or curb line, with pumper connection facing roadway and with body flange set at elevation of 50 mm above final grade.
- .5 Place concrete thrust blocks as indicated and specified.
- .6 Place appropriate sign on installed hydrants indicating not are in service during construction.
- .7 Install hydrant at dead ends.

### **3.12 CONCRETE THRUST BLOCKS AND RESTRAINED JOINTS**

- .1 Place concrete thrust blocks between valves, tees, plugs, caps, bends, changes in pipe diameter, reducers, fire hydrants and fittings on undisturbed ground as indicated by the Owner or Consultant.
- .2 Cover with 8 myl poly to keep joints and couplings free of concrete.
- .3 Do not backfill over concrete within 24 hours after placing.
- .4 For restrained joints: only use restrained joints approved under Section 2.07.

### **3.13 HYDROSTATIC AND LEAKAGE TESTING**

- .1 Do tests in accordance with ANSI/AWWA C600.
- .2 Provide labour, equipment and materials required to perform hydrostatic and leakage tests hereinafter described.
- .3 Notify Owner and Consultant at least 24 hours in advance of proposed tests:
- .1 Perform tests in presence of Owner and Consultant.
- .4 Where section of system is provided with concrete thrust blocks, conduct tests at least 5 days after placing concrete.
- .5 Test pipeline in sections not exceeding 400 m in length, unless otherwise authorized by Owner or Consultant.
- .6 Upon completion of pipe laying and after Owner or Consultant has inspected Work in place, surround and cover pipes between joints with approved granular material placed to dimensions indicated

- .7 Leave fire hydrants and valves exposed for operation during testing.
- .8 Ensure all valves are in open position in testing section.
- .9 Expel air from main by slowly filling main with potable water from lowest elevation point.
  - .1 Install corporation stops at high points in main where no air-vacuum release valves or fire hydrants are installed.
  - .2 Remove stops after satisfactory completion of test and seal holes with brass plugs.
- .10 Apply hydrostatic test pressure of 1034 kPa based on elevation of lowest point in main and corrected to elevation of test gauge, for period of 2 hours.
- .11 The allowable leakage shall be determined by the following formula:  
$$Q = \frac{LD\sqrt{P}}{795,000}$$

Where Q = Allowable leakage, in liters/hour  
L = Length of pipe tested (m)  
D = Nominal Diameter (mm)  
P = Test Pressure (kpa)
- .12 When testing against a closed valve, an additional leakage of 0.0012 litres/hour/mm diameter/valve is allowed.
- .13 Measure leakage of water as measured by a water meter approved by the Owner or Consultant. Proof of recent calibration maybe required.
- .14 Locate and repair defects if leakage is greater than allowable amount.
- .15 Repeat test until leakage is within specified allowance for full length of water main. Repeated tests carried out at Contractor's expense. Repeated tests are to continue until all remedial measures have been successful.

### 3.14 FLUSHING AND DISINFECTING

- .1 Flushing and disinfection of water mains to completed after pressure test, in accordance with AWWA C651.
- .2 Flushing and disinfecting operations: under witness by Owner and Consultant carried out by specialist contractor.
  - .1 Notify Owner and Consultant at least 4 days in advance of proposed date when disinfecting operations will begin.
  - .2 Flush water mains through available outlets with a sufficient flow of potable water to produce velocity of 1.5 m/s, within pipe for minimum 10 minutes, or until foreign materials have been removed and flushed water is clear. Owner or Consultant must approve timing of flushing to ensure adequate water is available for customer use.
  - .3 Flushing flows as follows:

Pipe Size NPS	Flow (L/s) Minimum
150 and below	38

200	75
250	115
300	150

- .4 Provide connections and pumps for flushing as required.
- .5 If satisfactory results cannot be achieved by flushing, swab pipes by approved methods and re-flush.
- .6 Open and close valves, hydrants and service connections to ensure thorough flushing.
- .7 When flushing has been completed to Owner or Consultant approval, introduce chlorine solution as approved by Owner or Consultant into water main and ensure that it is distributed throughout entire system.
- .8 Rate of 1% chlorine solution application to be proportional to rate of water entering pipe. Chlorine application to be close to point of filling water main and to occur at same time. Prepare stock chlorine with concentrate of 1% free chlorine by volume as follows:

Product	Amount of Compound	Quality of Water
5.25% (CL)	1.0 liter	1.0 liter
10.5% (CL)	1.0 liter	7.0 liters

- .9 The following table indicates the quantity of 1% chlorine stock solution required per 100-meter length of pipe.

Pipe Diameter (mm)	1% Chlorine Stock Solution (liters)
100mm	4.9
150mm	10.9
200mm	19.4
250mm	30.4
300mm	42.9

- .10 Take water samples at all fire hydrants and termination points, in suitable sequence, to test chlorine residual. When tests indicate minimum chlorine residual of 50 mg/l, leave system charged with disinfection solution to ensure minimum chlorine solution of 25 mg/l throughout system after 24 hours.
- .11 Operate valves, fire hydrants and appurtenances while main contains chlorine solution.
- .12 Flush line to remove chlorine solution after 24 hours. Add 1% Hydrogen Peroxide reducing agent to the disinfectant solution at point of discharge or within a retention

facility such that the solution is disposed to the environment with a 0.0 chlorine residual. Check chlorine residual before disposal and at regular intervals during disposal to ensure compliance. The dichlorination requirement can only be excluded with written consent of the New Brunswick Department of Environment and Local Government.

- .13 Dispose of dechlorinated disinfectant solution. Where disposing to the environment, disposal of the dechlorinated solution must be at least 100 m from the nearest watercourse.
- .14 Where disinfectant solution is dechlorinated at point of discharge, inject stock reducing agent at a rate proportional to discharge rate. Injection and discharge rates must be monitored continuously to ensure proper proportioning.
- .15 Prepare stock reducing agent by volume with concentration of 1% hydrogen peroxide by mass. Using liquid reducing agent (35% By Mass), for 1 liter of agent use 34 liters of water.
- .16 The following table indicates quantity of 1% hydrogen peroxide required to reduce total chlorine residual of disinfectant solution per 100-meter length of pipe, 50 mg/l to 0 mg/l.

Pipe Diameter (mm)	1% Chlorine Stock Solution (liters)
100mm	4.5
150mm	10.2
200mm	18.1
250mm	28.2
300mm	40.6

- .17 Measure chlorine residuals at furthest end of pipeline being tested.
- .18 Perform bacteriological tests on water main, after chlorine solution has been flushed out:
  - .1 Take samples on two (2) consecutive days 24 hours apart.
  - .2 Coliform tests must indicate 0 on two consecutive days combined with background count of less than 15.
  - .3 Should contamination remain or recur during this period, repeat disinfecting procedure.
  - .4 Contractor to submit copy of test results from an accredited laboratory to Owner for acceptance.

### 3.15 SURFACE RESTORATION

- .1 After installing and backfilling over water mains, restore surface to original condition as

directed by Owner or Consultant

### **3.16 CLEANING**

- .1 Refer to Section 01 00 00 – Project Specific General Requirements.

**END OF SECTION**

## **1 GENERAL**

### **1.1 DESCRIPTION**

- .1 This section specifies the requirements for supplying and installing various diameters of sanitary gravity sewer and sanitary gravity sewer laterals. Work includes excavation, supply and installation of pipe, fittings, bedding materials, backfill, compaction and testing of pipe as shown on the associated drawings.

### **1.2 REFERENCE STANDARDS**

- .1 ASTM C828-11(2011), Standard Test Method for Low-Pressure Air Test of Vitrified Clay Pipe Lines.
- .2 ASTM D3034-21, Standard Specification for Type PSM Poly(Vinyl Chloride) (PVC) Sewer Pipe and Fittings.
- .3 ASTM D3212-21, Standard Specification for Joints for Drain and Sewer Plastic Pipes Using Flexible Elastomeric Seals.
- .4 ASTM F477-14(2021), Standard Specification for Elastomeric Seals (Gaskets) for Joining Plastic Pipe.
- .5 ASTM C443M-21, Standard Specification for Joints for Concrete Pipe and Manholes, Using Rubber Gaskets (Metric).
- .6 ASTM C76M-22a, Standard Specification for Reinforced Concrete Culvert, Storm Drain, and Sewer Pipe (Metric).
- .7 CSA B1800:21, Thermoplastic Nonpressure Piping Compendium (Standard CSA B182.2).
- .8 CSA A257 Series:19, Standards for Concrete Pipe and Manhole Sections.

### **1.3 SCHEDULE OF WORK**

- .1 Scheduling: refer to Section 01 00 00 – Project Specific General Requirements.
- .1 Schedule Work to minimize interruptions to existing services and maintain existing sewage flows during construction.
- .2 Submit schedule of expected interruptions for approval and adhere to approved schedule.
- .3 Notify Owner or Consultant 24 hours minimum in advance of any interruption in service.

### **1.4 DELIVERY, STORAGE AND HANDLING**

- .1 Deliver, store and handle materials in accordance with manufacturer's written instructions.

- .2 Delivery and acceptance requirements: deliver materials to Site in original factory packaging, labelled with manufacturer's name and address.
- .3 Storage and Handling Requirements:
  - .1 Store materials in accordance with manufacturer's recommendations.
  - .2 Store and protect pipes from damage.
  - .3 Replace defective or damaged materials with new.

## 1.5 MEASUREMENT FOR PAYMENT

- .1 Payment for sewer main pipe and sewer laterals shall be per linear metre (m) of completed pipe. The measurement for payment of completed pipe shall include the supply of all labour, materials and equipment for excavation, disposal of surplus or unsuitable excavated materials, shoring, dewatering, by-pass pumping, bedding, supply & installation of pipe, backfilling, compaction, flushing, testing of pipe and all incidental items.
- .2 Sewer mains shall be measured between centres of manholes. Sewer laterals shall be measured from the center of the sewer main to the end cap or connection at the property line.
- .3 Sewer fittings to be measured for payment on a per unit basis. The unit price includes excavation, supply and installation of fittings, bedding materials, backfill, compaction and all incidental items.
- .4 Connecting each sewer lateral shall be paid on a per unit basis and shall include all necessary labour, material and equipment to connect the lateral to the sewer main or manhole. This shall include, where necessary, the following
  - .1 The proper tee or "tee wye" on the main, approved saddle or proper manhole connection,
  - .2 Any necessary bends, plus any other labour and materials necessary for making the connection, and;
  - .3 Pipe end cap for new service or approved coupling when connecting to existing service.
- .5 Pipe insulation to be measured in square metres (m<sup>2</sup>) placed and to be based on 50 mm thickness.
- .6 Sanitary or storm service inspection chambers to be measured for payment on a per unit basis including all excavation, backfilling, connections and incidentals.
- .7 Measurement for payment for abandonment of sewer mains with grout to be based on theoretical pipe volume per cubic metre (m<sup>3</sup>) basis and shall include the supply and installation of grout and all incidentals. Any losses in volume pumped are to be considered incidental.
- .8 Payment for video inspection to be measured on a per metre (m) basis from centre of manhole to centre of manhole and payment shall be based on a unit price basis. Video inspection is to be completed on both main line piping and service laterals at the connection point.

## **2 PRODUCTS**

### **2.1 PLASTIC PIPE**

.1 Type PSM Polyvinyl Chloride (PVC): to ASTM D3034 and CSA B182.2.

- .1 Standard Dimensional Ratio (SDR): 35
- .2 Locked-in gasket and integral bell system.
- .3 Minimum sanitary sewer gravity main diameter: 200mm
- .4 Colour coded Green

### **2.2 CONCRETE PIPE**

.1 Reinforced concrete pipe: to CSA A257, ASTM C76M and minimum Class 65D (Class III), designed for flexible rubber gasket joints to CSA A257 and ASTM C443M.

.2 All reinforced concrete pipe to be pre-tested prior to shipment. Minimum 3 pipe per test section. All pipe passing pre-testing to be labelled as passed or tested and documentation of the testing to accompany the delivery of the pipe.

.3 Lifting holes:

- .1 Pipe 900 mm and less diameter - no lift holes.
- .2 Pipe greater than [900] mm diameter - lift holes not to exceed [two] in a piece of pipe.
- .3 Provide prefabricated plugs to seal lift holes tight after installation of pipe.

### **2.3 SERVICE CONNECTIONS**

.1 Type PSM Polyvinyl Chloride (PVC) lateral pipe: To ASTM D3034 and CSA B182.2.

- .1 Standard Dimensional Ratio (SDR): 35.
- .2 Locked-in gasket and integral bell system.
- .3 Minimum sanitary sewer service pipe diameter: 100mm
- .4 Colour coded Green

.2 Service connections tees and fittings to PVC main: To ASTM D3034 and CSA B182.2.

- .1 Connection to new PVC main to be PVC, Standard Dimensional Ratio (SDR): 35 with a locked-in gasket and integral bell system.
- .2 Connection to existing PVC main to be "Inserta-Tee" To ASTM F477 and ASTM D3212 or "Quick Seal" or "EZ-Tee" with stainless steel clamp to ASTM C 923 complete with locked-in gaskets.
- .3 Bends shall be of the long radius type only.

.3 Service connections tees to reinforced concrete main: To ASTM F477 and ASTM D3212.

- .1 Connection to reinforced concrete main to be "Inserta-Tee" or "Quick Seal" or "EZ-

Tee" with stainless steel clamp to ASTM C 923 complete with locked-in gaskets

## 2.4 COUPLINGS

- .1 Couplings connecting PVC to PVC: Type PSM Polyvinyl Chloride (PVC): to ASTM D3034 and CSA B182.2.
  - .1 Standard Dimensional Ratio (SDR): 35.
  - .2 Locked-in gasket and integral to coupling.
- .2 Couplings connecting dissimilar pipe:
  - .1 Flexible Rubber Repair Coupling.
  - .2 Stainless steel bands with stainless steel shear ring.
  - .3 Acceptable products:
    - .1 Fernco.
    - .2 Mission.
    - .3 Indiana Steel.
    - .4 Approved equal.

## 2.5 INSULATION

- .1 Insulation for sewer mains and laterals shall be a 50 mm thick Styrofoam insulation board:
- .2 Acceptable products:
  - .1 Dow HI40.
  - .2 Owens Corning Formular 400.
  - .3 Approved equal.

## 2.6 PIPE BEDDING

- .1 Granular bedding material for PVC pipe to Section 31 05 16 - Aggregate Materials and following requirements:
  - .1 Crushed or screened stone.
- .2 Granular bedding material for reinforced concrete pipe to Section 31 05 16 - Aggregate Materials and following requirements:
  - .1 Pit run gravel, screened pit run or crushed rock.
  - .2 Compacted to 95 % standard proctor density for under pavement or sidewalks.
  - .3 Compacted to 90 % standard proctor density for grassed areas.

## 2.7 BACKFILL MATERIAL

- .1 Selected backfill in accordance with Section 32 11 23 - Aggregate Placement and subbase and base in accordance with Section 31 23 33.01 - Excavating, Trenching and Backfilling.

- .2 Unshrinkable fill: to Section 31 23 33.01 - Excavating, Trenching and Backfilling.

### **3 EXECUTION**

#### **3.1 EXAMINATION**

- .1 Verification of conditions: verify that conditions of substrate previously installed under other sections or contracts are acceptable for sewer pipe installation in accordance with manufacturer's written instructions.
- .1 Visually inspect substrate in presence of Owner or Consultant.
  - .2 Inform Owner or Consultant of unacceptable conditions immediately upon discovery.
  - .3 Proceed with installation only after unacceptable conditions have been remedied.

#### **3.2 PREPARATION**

- .1 Clean pipes, fittings and appurtenances of accumulated debris and water before installation:
- .1 Inspect materials for defects to approval of Owner or Consultant.
  - .2 Remove defective materials from the Site as directed by Owner or Consultant.

#### **3.3 TRENCHING**

- .1 Do trenching Work in accordance with Section 31 23 33.01 - Excavating, Trenching and Backfilling.
- .2 Protect trench from contents of sewer or sewer connection.
- .3 Trench alignment and depth require approval of Owner or Consultant prior to placing bedding material and pipe.

#### **3.4 GRANULAR BEDDING**

- .1 Place granular bedding materials in uniform layers not exceeding 150 mm thickness to depth of 150 mm below invert of pipe.
- .2 Do not place material in frozen condition.
- .3 Shape bed true to grade to provide continuous, uniform bearing surface for pipe.
- .1 Do not use blocks when bedding pipe.
- .4 Shape transverse depressions in bedding as required to suit joints.
- .5 Hand place bedding material in uniform layers not exceeding 150 mm thickness as indicated.
- .1 Do not dump material directly onto pipe.

- .6 Place layers uniformly and simultaneously on each side of pipe.
- .7 Place each layer from bottom of trench to haunch line of pipe and chink to underside of pipe.
- .8 For pit run bedding on reinforced concrete pipe, compact each layer as required in Section 2.06.
- .9 Place each layer from haunch line of pipe to underside of backfill.
- .10 Fill excavation below bottom of specified bedding adjacent to manholes or structures with bedding material.
- .11 Fill authorized or unauthorized excavation below design elevation of bottom of specified bedding in accordance with Section 31 23 33.01 – Excavation, Trenching and Backfilling with compacted pit run gravel or approved equal.
- .12 Prior to placing backfill, install filter fabric from top of screened stone bedding full width of trench.

### **3.5 BACKFILL**

- .1 Place selected backfill, subbase and base materials, above pipe bedding in uniform layers not exceeding 150 mm compacted thickness up to grades as indicated.
- .2 Do not place backfill material in frozen condition.
- .3 Under asphalt and sidewalks, compact backfill to at least 95% standard proctor density.
  - .1 In other grassed areas, compact to at least 90% standard proctor density.

### **3.6 PIPE INSTALLATION**

- .1 Handle pipe using methods approved by Owner or Consultant.
  - .1 Do not use chains or cables passed through rigid pipe bore so that weight of pipe bears upon pipe ends.
- .2 Lay pipes on prepared bed, true to line and grade, with pipe invert smooth and free of sags or high points.
  - .1 Ensure barrel of each pipe is in contact with shaped bed throughout its full length.
- .3 Begin laying at outlet and proceed in upstream direction with bell ends of pipe facing upgrade.
- .4 Joint deflection permitted within limits recommended by pipe manufacturer.
- .5 Water not to flow through pipe during construction, unless permitted Owner or Consultant.
- .6 Whenever Work is suspended, install removable watertight bulkhead at open end of last pipe laid to prevent entry of foreign materials.
- .7 Install plastic pipe and fittings in accordance with CSA B182.11.
- .8 Pipe jointing:
  - .1 Install gaskets in accordance with manufacturer's written recommendations.

- .2 Support pipes with hand slings or crane as required to minimize lateral pressure on gasket and maintain concentricity until gasket is properly positioned.
- .3 Align pipes before joining.
- .4 Maintain pipe joints free from mud, silt, gravel and foreign material.
- .5 Avoid displacing gasket or contaminating with dirt or foreign material. Gaskets so disturbed to be removed, cleaned and lubricated and replaced before joining is attempted.
- .6 Complete each joint before laying next length of pipe.
- .7 Minimize joint deflection after joint has been made to avoid joint damage.
- .8 At rigid structures, install pipe joints not more than 1.2 m from side of structure.
- .9 Apply sufficient pressure in making joints to ensure that joint is complete as outlined in manufacturer's recommendations.
- .9 When stoppage of Work occurs, block pipes as directed by Owner or Consultant to prevent creep during down time.
- .10 Plug lifting holes with prefabricated plugs or grout approved by Owner or Consultant.
- .11 Cut pipes as required for special inserts, fittings or closure pieces as recommended by pipe manufacturer, without damaging pipe or its coating and to leave smooth end at right angles to axis of pipe.
- .12 Make watertight connections to manholes.
- .13 Use prefabricated couplings for field connections approved by Owner or Consultant for connecting pipes to existing sewer pipes of same material.
  - .1 Joints to be structurally sound and watertight.
- .14 When connecting dissimilar sewer pipe materials, use a flexible rubber repair coupling, with stainless steel bands and stainless-steel sheer ring, or approved equal.

### **3.7 SERVICE CONNECTIONS**

- .1 Install pipe to CSA B182.11 and manufacturer's instructions and specifications.
- .2 Maintain grade for 100 mm diameter sewers at 2 % minimum unless directed by Owner or Consultant.
- .3 Service connections to main sewer: Molded PVC Tee fitting for PVC pipe connection and Inserta-Tee for Concrete pipe connection.
  - .1 Do not use break-in and mortar patch-type joints.
- .4 Service connection pipe: not to extend into interior of main sewer.
- .5 Make up required horizontal and vertical bends from 45 degrees bends or less, separated by straight section of pipe with minimum length of 4 pipe diameters.
  - .1 Use long sweep bends where applicable.
- .6 Plug service laterals with watertight caps or plugs.
- .7 Place location marker at ends of plugged or capped unconnected sewer lines.

- .1 Each marker: 38 x 89 mm stake extending from pipe end at pipe level to 600 mm above finished grade in grassed areas and 600 mm below finished grade in asphalt areas to locate pipe end.
- .2 Paint exposed portion of stake green with designation SAN SWR LINE in black.

### 3.8 FIELD TESTING

- .1 All sewers 900 mm or less and 100mm or greater to be tested.
- .2 Remove foreign material from sewers and related appurtenances by flushing with water.
  - .1 Flushing to be completed with high pressure flushing equipment capable of removal and collection of debris.
  - .2 All debris is to be collected and prevented from entering other sections of sewer mains outside the Work area.
- .3 All sewers to be video inspected:
  - .1 All closed-circuit television inspection (CCTV) work shall conform to National Association of Sewer Service Companies (NASSCO) – Pipeline Assessment Certification Program (PACP) standards.
  - .2 Camera operator shall be a PACP certified operator and proof of certification shall be submitted to the Owner or Consultant prior to starting CCTV.
  - .3 Sewers to be videoed with colored (CCTV) from manhole to manhole.
  - .4 Camera shall be capable of tilt and pan.
  - .5 Camera shall pause, tilt and pan at all end pipes, service lateral connections, pipe defects, sags, etc.
  - .6 All inspections shall accurately measure linear distance. Measurements shall be accurately displayed in the videos.
  - .7 All videos and pdf video inspection reports are to be submitted to the Owner or Consultant at the completion of the Work.
  - .8 No asphalt restoration is to be completed until videos and reports have been submitted and reviewed by the Owner or Consultant.
  - .9 All defects identified in the videos and reports are to be corrected prior to asphalt restoration.
  - .10 Building Permit(s) will not be issued until Owner or Consultant has reviewed both the passing Air Test(s), following 3.8.8 as outlined below, and the Sanitary Inspection Video.
- .4 Perform exfiltration testing as soon as practicable after jointing and bedding are complete, and service connections have been installed.
- .5 Do exfiltration test to ASTM C828.
- .6 Do exfiltration testing as specified herein.
  - .1 Perform tests in presence of Owner and Consultant.
  - .2 Notify Owner and Consultant 24 hours minimum in advance of proposed tests.

- .7 Carry out tests on each section of sewer between successive manholes including service connections.
- .8 Exfiltration test (Air):
  - .1 Air tests only to be completed on pipe 600 mm PVC or less. For large diameter reinforced concrete pipe, consult with Owner or Consultant for acceptable test method.
  - .2 Use equipment design to operate above ground. Equipment to include air compressor, air relief valve and pressure gauge from 0 – 70 kpa with accuracy of + or – 0.25 kpa.
  - .3 Supply and install plugs at each end of section to be tested with one end equipped with air inlet connection.
  - .4 Fill test section with air to a constant pressure of 28 kpa.
  - .5 Allow period of 2 minutes for air temperature to stabilize, adding air to only maintain 28 kpa.
  - .6 Decrease pressure to 24 kpa. Measure time required for pressure to reach 17 kpa. Following table is minimum time for pressure drop:

Pipe Diameter (mm)	Minimum Time (mm:ss)
100mm	1:53
150mm	2:50
200mm	3:47
250mm	4:43
300mm	5:40
375mm	7:05
450mm	8:30
525mm	9:55
600mm	11:20

- .9 Repair and retest sewer line as required, until test results are within limits specified.
- .10 Repair visible leaks regardless of test results.

**3.9 CLEANING**

- .1 Refer to Section 01 00 00 – Project Specific General Requirements.

**END OF SECTION**

## **1 GENERAL**

### **1.1 DESCRIPTION**

- .1 This section specifies the requirements for supplying and installing various diameters of sanitary sewer force main. Work includes excavation, supply and installation of pipe, fittings, bedding materials, backfill, compaction and testing of pipe as shown on the associated drawings.

### **1.2 REFERENCE STANDARDS**

- .1 ANSII/AWWA C105/A21.5-18, Polyethylene Encasement for Ductile-Iron Pipe Systems.
- .2 ANSI/AWWA C110/A21.10-21, Ductile-Iron and Gray-Iron Fittings.
- .3 ANSI/AWWA C111/A21.11-17, Rubber-Gasket Joints for Ductile-Iron Pressure Pipe Fittings.
- .4 ANSI/AWWA C153/A21.53-19, Ductile-Iron Compact Fittings.
- .5 ANSI/AWWA C205-18, Cement-Mortar Protective Lining and Coating for Steel Water Pipe, 4 In. (100 mm) and Larger, Shop Applied.
- .6 ANSI/AWWA C208-17, Dimensions for Fabricated Steel Water Pipe Fittings.
- .7 ASTM A307-21, Standard Specification for Carbon Steel Bolts, Studs, and Threaded Rod 60 000 PSI Tensile Strength.
- .8 ASTM C94/C94M-22a, Standard Specification for Ready-Mixed Concrete.
- .9 ASTM D698-00, Standard Test Methods for Laboratory Compaction Characteristics of Soil Using Standard Effort (12,400 ft-lbf/ft<sup>3</sup> (600 kN-m/m<sup>3</sup>)).
- .10 ASTM F1674-18, Standard Test Method for Joint Restraint Products for Use with PVC Pipe.
- .11 CSA-A23.1:19/A23.2:19, Concrete Materials and Methods of Concrete Construction/Test Methods and Standard Practices for Concrete.

### **1.3 SCHEDULE OF THE WORK**

- .1 Scheduling: Refer to Section 01 00 00 – Project Specific General Requirements.
- .1 Schedule Work to minimize interruptions to existing services and maintain existing sewage flows during construction.
- .2 Submit schedule of expected interruptions for approval and adhere to approved schedule.
- .3 Notify Consultant 24 hours minimum in advance of any interruption in service.

## **1.4 DELIVERY, STORAGE AND HANDLING**

- .1 Deliver, store and handle materials in accordance with manufacturer's written instructions.
- .2 Delivery and Acceptance Requirements: deliver materials to Site in original factory packaging, labelled with manufacturer's name and address.
- .3 Storage and Handling Requirements:
  - .1 Store materials in accordance with manufacturer's recommendations.
  - .2 Store and protect pipes from damage.
  - .3 Replace defective or damaged materials with new.

## **1.5 MEASUREMENT FOR PAYMENT**

- .1 Payment for forcemain shall be per linear metre (m) of forcemain installed measured horizontally. The measurement of completed forcemain shall include the supply of all labour, materials and equipment for excavation, disposal of surplus or unsuitable excavated materials, shoring, dewatering, bedding, supply & installation of pipe, backfilling, compaction, flushing, testing of pipe and all incidental items.
- .2 Forcemain fittings such as bends, tees, etc. shall be paid based on each unit installed, including all labour, materials and equipment, thrust blocks, restrainers, excavation, bedding and backfilling plus all incidental items.
- .3 Measurement for payment for abandonment of sewer mains with grout to be based on theoretical pipe volume per cubic metre (m<sup>3</sup>) basis and shall include the supply and installation of grout and all incidentals. Any losses in volume pumped are to be considered incidental.
- .4 Payment for video inspection shall be measured on a per metre (m) basis from centre of manhole (or Sewage Lift Station) to centre of manhole and shall be paid on a unit price basis.

## **2 PRODUCTS**

### **2.1 PIPES, JOINTS AND FITTINGS**

- .1 Force mains shall be:
  - .1 Ductile iron pipe: to ANSI/AWWA C151/A21.51, pressure class depended upon design requirements and to be cement mortar lined to ANSI/AWWA C104/A21.4 in 100 mm sizes and larger.
  - .2 All ductile iron in buried installation shall be polyethylene encased (wrapped) meeting the requirements of latest AWWA C105.
  - .3 Ductile iron pipe for flanged ends: to ANSI/AWWA C151/A21.51, special class 54 for cement mortar lined to ANSI/AWWA C104/A21.4 in 100 mm sizes. Flanged pipe not to be used in buried applications.

- .4 Polyvinyl chloride pressure pipe: to ANSI/AWWA C900, pressure class depended upon design requirements, cast iron outside diameter in sizes 100 mm to 300 mm.
- .5 Joints and fittings for.
  - .1 Joints Ductile Iron:
    - .1 Push-on joints: to ANSI/AWWA C111/A21.11.
    - .2 Rubber gasket for mechanical pipe joints: to ANSI/AWWA C111/A21.11.
    - .3 Rubber gasket for flange pipe joints 1.6 mm thick: to ANSI/AWWA C111/A21.11.
    - .4 Bolts, nuts, hex head with washers: to ASTM A307, heavy series.
- .6 Joints PVC:
  - .1 Push-on joints: watertight.
  - .2 Rubber gaskets for pipe joints: to ANSI/AWWA C111/A21.11.
  - .3 Bell to be integral and homogeneous part of pipe.
- .7 Fittings:
  - .1 Mechanical joint cast iron and ductile iron fittings NPS 100 mm and larger: to ANSI/AWWA C110/A21.10.
  - .2 Flanged cast iron fittings NPS 100 mm and larger: to ANSI/AWWA C110/A21.10.
  - .3 Compact Fittings to ANSI/AWWA C153/A21.53.
  - .4 Pipe fittings: to ANSI/AWWA C208, cement mortar lined to ANSI/AWWA C205, and exterior protected with epoxy coated.
  - .5 Fittings to include bends and couplings.
  - .6 Rubber gasket for mechanical joints to be transition gaskets where pipe outside diameter is not DIPS.

## 2.2 CATHODIC PROTECTION

- .1 Provide means of protection for ductile iron pipe with 8-mil poly wrap in accordance with ANSI/AWWA C105/A21.5.
- .2 Criteria for corrosion protection shall meet or exceed National Association of Corrosion Engineers standard RP0169 latest addition.
- .3 Anode Corrosion Protection:
  - .1 All mechanical joint fittings including tees, crosses, bends, couplings, caps and valves 200 mm diameter or less to be protected with 5.4 kg zinc anode.
  - .2 All hydrants, corporation stop, curb stop, copper service longer than 20 meters and tees, crosses, bends, caps and valves greater than 200 mm but less than 350 mm to be

protected with 11 kg zinc anode.

.3 Acceptable products for Zinc Anode suppliers are:

- .1 Interprovincial Corrosion Control.
- .2 Corrosion Services.
- .3 Exothermal Industries.
- .4 Integrity Anode Corporation.
- .5 Bren Technologies Inc.

.4 Anodes shall be installed by wrapping around bolts and securing with a second nut.

.4 Anti-corrosion petrolatum paste, mastic and tape:

- .1 Shall be applied on all fittings greater than 300 mm.
- .2 Prior to applying the paste, surface of fittings to be free of loose coating, rust soil, and any other foreign matter.
- .3 Technique for applying paste, mastic and wrap is to be followed as per manufacture specifications.
- .4 Acceptable products for petrolatum paste, mastic and tape systems are as follows:
  - .1 Petro Coating Systems.
  - .2 PetroWrap.
  - .3 STAC.
  - .4 Trenton.
  - .5 Denso.
  - .6 PetroGuard.
  - .7 Approved equivalent.

## 2.3 VALVES AND VALVE BOXES

.1 Gate Valves:

- .1 Gate valves to open counterclockwise.
- .2 Gate valves to be complete with steel tee bolts and nuts and a 50 mm square operating nut.
- .3 Gate valves are to be used in all valves up to and including 300 mm diameter.
- .4 All gate valves to be FM approved and ULC listed.
- .5 Gate valves: to be resilient seated conforming to ANSI/AWWA C509 or C515, epoxy coated interior and exterior, standard cast iron body, brass mounted wedge valves encapsulated with rubber, non-rising stems, suitable for 1 Pa with mechanical joints.
- .6 Acceptable products for gate valves are as follows:
  - .1 Clow Model 2639/2640.
  - .2 Mueller Model 2361.
  - .3 Approved equivalent.

- .2 Cast iron valve boxes:
  - .1 Three piece sliding type adjustable over minimum of 450 mm.
  - .2 Base to be large round type with minimum diameter of 300 mm complete with centering disc.
  - .3 Size of box to be 130 mm.
  - .4 Acceptable products for valve boxes are as follows:
    - .1 Bibby Ste-Croix.
    - .2 Mueller Canada.
    - .3 Star Pipe Canada.
    - .4 Approved equivalent.

## 2.4 COUPLINGS

- .1 In all cases where full mechanical joint gray-iron or ductile iron couplings combined with mechanical joint restraints can be used, they are to be the preferred coupling system.
- .2 If sleeve style coupling is required, acceptable coupling will require Owner or Consultant approval before use.

## 2.5 PIPE RESTRAINTS FOR MECHANICAL JOINTS AND THRUST BLOCKS

- .1 Pipe restraints: Pipe restraints to be used on all mechanical joints:
  - .1 Pipe Restraints to be used in combination with thrust blocks on all bends, couplings, etc.:
    - .1 Pipe restraints to be cast iron supplied with fusion-bonded epoxy.
    - .2 Pipe restraints to have a minimum working pressure of 1034 kpa.
    - .3 Pipe restraints shall be in accordance with latest addition of ASTM F1674.
    - .4 Pipe restraints to have a minimum working pressure of 1034 kpa.
- .2 Pipe restraints acceptable products for PVC pipe:
  - .1 Clow 300 C restrainer.
  - .2 EBAA IRON Series 2000 PV.
  - .3 Uni-Flange Series 1300/1500.
  - .4 Sigma One-Lok SLC Series.
  - .5 Star Pipe Products PVC Stargrip Series 4000.
  - .6 Star Pipe Products PVC Ring Lock Series 3500.
  - .7 Clow TUFgrip Dual Wedge Restraint (Universal).
  - .8 Approved equivalent.
- .3 Pipe restraints acceptable products for ductile iron pipe:
  - .1 EBAA IRON Series 1100.
  - .2 Romac Industries RomaGrip.
  - .3 Sigma One-Lok SLD Series.

- .4 Star Pipe Products PVC Stargrip Series 3000.
- .5 Clow TUF Grip Dual Wedge Restraint (Universal).
- .6 Approved equivalent.

.4 Concrete thrust block:

- .1 Cast-in-place thrust blocks shall be installed on all bends, couplings, etc.
- .2 Thrust block design and dimensions shall be as shown on the Standard Detail Drawings.
- .3 All thrust blocks shall bear against undisturbed soil.
- .4 All concrete used for thrust blocks shall be ready-mix concrete from supplier certified under ASTM C94 and CSA-A23.1.
- .5 Concrete used for thrust blocks to be 32 Mpa at 28 days.
- .6 Prior to pouring concrete thrust block, place 8 mil poly barrier around fitting. Fitting bolts, nuts and washers to be accessible after the thrust block has been poured.

## 2.6 INSULATION

- .1 Extruded polystyrene foam insulation board for force mains is to be used when depth of cover of 1.8 m cannot be achieved and when crossing under or over storm sewers. Acceptable products for foam board insulation are as follows:
  - .1 Styrofoam HI 40.
  - .2 Foamular 400.
  - .3 Approved equivalent.
- .2 Curved insulation to be used on chambers and other specified locations as directed by Owner or Consultant.
  - .1 Expanded polystyrene insulation with woven white polypropylene radiant blocker facing, laminated both sides of core.
  - .2 White laminated facing to be treated for acid and UV resistance.
  - .3 Board to have a bursting strength of 172 lbs/sq. inch.
  - .4 The facing shall extend beyond the edge forming a self-adhesive overlap flap.
  - .5 Acceptable products for curved insulation board are as follows:
    - .1 Alleguard SilverBoard 25 (SB25HD)
    - .2 Approved equivalent.

## 2.7 TRACER WIRE

- .1 Tracer wire will be required on all PVC force main.
- .2 Tracer wire shall be RWU90, 10-gauge (AWG), single strand, insulated copper wire with cross-linked polyethylene (XLPE) insulation, specifically manufactured for direct bury applications.

- .3 All spliced or repaired wire connections in the tracer wire system shall be made using appropriate connectors. Acceptable products for connectors are as follows:
- .1 DryConn Direct Bury Lug-Aqua connectors.
  - .2 Approved equivalent.
- .4 All bare ends of tracer wire connections to be enclosed and waterproofed. Acceptable products for connector ends are as follows:
- .1 DryConn King 6 Blue connectors.
  - .2 Approved equivalent.
- .5 Tracer wire shall be attached to the top of the pipe at every fitting, valve and at intervals not exceeding 1.0 m using 50 mm wide tape. Tape shall also be used to attached tracer wire to valve boxes. Acceptable products for tape are as follows:
- .1 T-Tape Gray PE, by Tapecoat.
  - .2 Approved equivalent.

## **2.8 PIPE BEDDING**

- .1 Pipe bedding and surround material to Section 31 05 16 - Aggregate Materials and following requirements:
- .1 Crushed or screened stone.

## **2.9 BACKFILL MATERIAL**

- .1 Selected backfill in accordance with Section 32 11 23 - Aggregate Placement, and subbase and base in accordance with Section 31 23 33.01 - Excavating, Trenching and Backfilling.
- .2 Unshrinkable fill: to Section 31 23 33.01 - Excavating, Trenching and Backfilling.

## **3 EXECUTION**

### **3.1 EXAMINATION**

- .1 Verification of conditions: verify that conditions of substrate previously installed under other Sections or Contracts are acceptable for distribution piping installation in accordance with manufacturer's written instructions:
- .1 Visually inspect substrate in presence of Owner or Consultant.
  - .2 Inform Owner or Consultant of unacceptable conditions immediately upon discovery.
  - .3 Proceed with installation only after unacceptable conditions have been remedied.

### **3.2 PREPARATION**

- .1 Clean pipes, fittings, valves and appurtenances of accumulated debris and water before

installation:

- .1 Inspect materials for defects to approval of Owner or Consultant.
- .2 Remove defective materials from Site as directed by Owner or Consultant.

### **3.3 TRENCHING**

- .1 Do trenching work in accordance with Section 31 23 33.01 - Excavating, Trenching and Backfilling.
- .2 Ensure trench depth allows coverage over pipe of 1.8 m minimum from finished grade.
- .3 Trench alignment and depth require Owner or Consultant approval prior to placing bedding material and pipe.

### **3.4 GRANULAR BEDDING**

- .1 Place granular bedding material in uniform layers not exceeding 150 mm compacted thickness to depth of 150 mm below invert of pipe.
- .2 Do not place material in frozen condition.
- .3 Shape bed true to grade to provide continuous uniform bearing surface for pipe.
- .4 Shape transverse depressions in bedding as required to suit joints.
- .5 Grade each layer full width of bed to prior to placement of next layer.
- .6 Fill authorized or unauthorized excavation below design elevation of bottom of specified bedding in accordance with Section 31 23 33.01 - Excavating, Trenching and Backfilling with compacted pit run gravel or approved equivalent.

### **3.5 BACKFILL**

- .1 Place selected backfill, subbase and base materials, above pipe bedding, in uniform layers not exceeding 150 mm compacted thickness up to grades as indicated.
- .2 Do not place backfill materials in frozen condition.
- .3 Under paving and walks, compact backfill to at least 95% corrected maximum dry density 95% maximum density to ASTM D698.
- .4 In other areas, compact to at least 90% corrected maximum dry density 90% maximum density to ASTM D698.

### **3.6 PIPE INSTALLATION**

- .1 Lay ductile iron pipes to ANSI/AWWA C600 and PVC to manufacturer's standard instructions and specifications:
  - .1 Do not use blocks except as specified.
- .2 Join ductile iron pipes in accordance with ANSI/AWWA C600 and PVC to manufacturer's

- recommendations.
- .3 Bevel or taper ends of PVC pipe to match fittings.
  - .4 Handle pipe by methods approved by Owner or Consultant and recommended by pipe manufacturer. Do not use chains or cables passed through pipe bore so that weight of pipe bears on pipe ends.
  - .5 Lay pipes on prepared bed, true to line and grade:
    - .1 Ensure barrel of each pipe is in contact with shaped bed throughout its full length.
    - .2 Take up and replace defective pipe.
    - .3 Correct pipe which is not in true alignment or grade or pipe which shows differential settlement after installation greater than 10 mm in 3 m.
  - .6 Face bell ends of pipe in direction of laying and up-grade.
  - .7 Do not exceed permissible deflection at joints as recommended by pipe manufacturer.
  - .8 Keep jointing materials and installed pipe free of dirt and water and other foreign materials:
    - .1 Whenever work is stopped, install a removable watertight bulkhead/cap at open end of last pipe laid to prevent entry of foreign materials.
  - .9 Position and join pipes with equipment and methods approved by Owner or Consultant.
  - .10 Cut pipes in approved manner as recommended by pipe manufacturer, without damaging pipe or its coating and to leave smooth end at right angles to axis of pipe.
  - .11 Align pipes before jointing.
  - .12 Install gaskets to manufacturer's recommendations. Support pipes with hand slings or crane as required to minimize lateral pressure on gasket and maintain concentricity until gasket is properly positioned.
  - .13 Avoid displacing gasket or contaminating with dirt or other foreign material:
    - .1 Remove disturbed or contaminated gaskets.
    - .2 Clean, lubricate and replace before jointing is attempted again.
  - .14 Complete each joint before laying next length of pipe.
  - .15 Minimize deflection after joint has been made.
  - .16 Apply sufficient pressure in making joints to ensure that joint is completed to manufacturer's recommendations.
  - .17 Ensure completed joints are restrained by compacting bedding material alongside and over installed pipes or as otherwise approved by Owner or Consultant.
  - .18 When stoppage of work occurs, block pipes in an approved manner to prevent creep during down time.
  - .19 Recheck plastic pipe joints assembled above ground after placing in trench to ensure that no movement of joint has taken place.
  - .20 Do not lay pipe on frozen bedding.
  - .21 Do hydrostatic and leakage test and have results approved by Owner and Consultant

before surrounding and covering joints and fittings with granular material.

- .22 Backfill remainder of trench.

### **3.7 TRACER WIRE INSTALLATION**

- .1 Tracer wire shall be installed on all sewage force mains. The wire shall be installed in such a manner as to be able to properly trace all sewage force mains without loss or deterioration of signal or without the signal migrating off the tracer wire. Refer to the Standard Drawing 33.SD08.
- .2 Tracer wire shall be laid flat and securely affixed to each fitting, valve, and top of the pipe at 1.0 m intervals, and to valve boxes and chambers using 50 mm wide T-Tape. Each piece of T-Tape shall be a minimum of 50 mm x 150 mm. Pipe shall be dry and cleaned of all dirt or dust where tape is to be applied.
- .3 The wire shall be protected from damage during the excavation or backfilling of the Works. No breaks or cuts in the tracer wire or tracer wire insulation shall be permitted.
- .4 Except for approved spliced connections, tracer wire shall be continuous and without splices.
- .5 Prior to cutting the tracer wire for connections, the tracing wire shall be loose and not taut to avoid stretching. The tracing wire shall be stripped the length required for the electrical connector using an appropriate wire-stripping tool. The exposed copper wire shall be free of nicks or scores. Wire ends that will be used for connecting the tracing device shall be stripped of insulation and have waterproof caps installed.
- .6 An approved electrical connector shall be placed over the exposed area of the main tracer wire. The connecting tracer wire shall be carefully inserted into the connector up to the insulation. The connection shall be tightened and the waterproof covers sealed shut. Connections shall be snug and free from exposed copper.
- .7 Continuity tests shall be conducted by the Contractor. Testing shall be done in the presence of and to the satisfaction of the Owner and Consultant. Tracing wire installations that fail the continuity testing shall be corrected and retested to the satisfaction of the Owner and Consultant. The Contractor shall provide the Owner and Consultant with sufficient notification of any testing.

### **3.8 VALVE INSTALLATION**

- .1 Install valves to manufacturer's recommendations at locations as indicated.
- .2 Support valves located in valve boxes by means of concrete located between valve and solid ground. Bedding same as adjacent pipe. Maximum length of pipe on each end of valve shall be 1 m. Valves not to be supported by pipe.

### **3.9 CONCRETE THRUST BLOCKS AND RESTRAINED JOINTS**

- .1 Place concrete thrust blocks between valves, bends, changes in pipe diameter, reducers and fittings on undisturbed ground as indicated by the Owner or Consultant.

- .2 Keep joints and couplings free of concrete.
- .3 Do not backfill over concrete within 24 hours after placing.
- .4 For restrained joints: only use restrained joints approved under Section 2.5.

### 3.10 HYDROSTATIC AND LEAKAGE TESTING

- .1 Do tests in accordance with ANSI/AWWA C600.
- .2 Provide labour, equipment and materials required to perform hydrostatic and leakage tests hereinafter described.
- .3 Notify Owner and Consultant at least 24 hours in advance of proposed tests:
  - .1 Perform tests in presence and Owner or Consultant.
- .4 Where section of system is provided with concrete thrust blocks, conduct tests at least 5 days after placing concrete.
- .5 Test pipeline in sections not exceeding 400 m in length, unless otherwise authorized by Owner or Consultant.
- .6 Upon completion of pipe laying and after Owner or Consultant has inspected Work in place, surround and cover pipes between joints with approved granular material placed to dimensions indicated
- .7 Leave valves exposed for operation during testing.
- .8 Ensure all valves are in open position.
- .9 Expel air from main by slowly filling main with potable water.
  - .1 Install corporation stops at high points in main where no air-vacuum release valves are installed.
  - .2 Remove stops after satisfactory completion of test and seal holes with plugs.
- .10 Apply hydrostatic test pressure of 1034 kPa based on elevation of lowest point in main and corrected to elevation of test gauge, for period of 2 hours.
- .11 The allowable leakage shall be determined by the following formula:

$$Q = \frac{LD\sqrt{P}}{795,000}$$

Where Q = Allowable leakage, in liters/hour  
L = Length of pipe tested (m)  
D = Nominal Diameter (mm)  
P = Test Pressure (kpa)

- .12 When testing against a closed valve, an additional leakage of 0.0012 liters/hour/mm diameter/valve is allowed.
- .13 Measure leakage of water as measured by a water meter approved by the Owner or Consultant. Proof of recent calibration maybe required.
- .14 Locate and repair defects if leakage is greater than amount specified.

- .15 Repeat test until leakage is within specified allowance for full length of force main. Repeated tests carried out at Contractor's expense. Repeated tests are to continue until all remedial measures have been successful.

### **3.11 SURFACE RESTORATION**

- .1 After installing and backfilling over force mains, restore surface to original condition as directed by Owner or Consultant.

### **3.12 CLEANING**

- .1 Refer to Section 01 00 00 – Project Specific General Requirements.

**END OF SECTION**

## **1 GENERAL**

### **1.1 DESCRIPTION**

- .1 This Section specifies the requirements for supplying and installing various diameters of storm sewer and storm sewer laterals. Work includes excavation, supply and installation of pipe, fittings, bedding materials, backfill, compaction and testing of pipe as shown on the associated drawings.

### **1.2 REFERENCE STANDARDS**

- .1 ASTM C76M-22a, Standard Specification for Reinforced Concrete Culvert, Storm Drain, and Sewer Pipe (Metric).
- .2 ASTM C443M-21, Standard Specification for Joints for Concrete Pipe and Manholes, Using Rubber Gaskets (Metric).
- .3 ASTM D3034-21, Standard Specification for Type PSM Poly(Vinyl Chloride) (PVC) Sewer Pipe and Fittings.
- .4 ASTM D3212-21, Standard Specification for Joints for Drain and Sewer Plastic Pipes Using Flexible Elastomeric Seals.
- .5 ASTM F477-14(2021), Standard Specification for Elastomeric Seals (Gaskets) for Joining Plastic Pipe.
- .6 ASTM F794-21, Standard Specification for Poly(Vinyl Chloride) (PVC) Profile Gravity Sewer Pipe and Fittings Based on Controlled Inside Diameter.
- .7 CSA A257 Series:19, Standards for Concrete Pipe and Manhole Sections.
- .8 CSA B1800;21, Thermoplastic Nonpressure Piping Compendium (Standard CSA B182.2).
- .9 CSA B1800;21, Thermoplastic Nonpressure Piping Compendium (Standard CSA B182.4).
- .10 CSA B1800;21, Thermoplastic Nonpressure Piping Compendium (Standard B182.11).

### **1.3 SCHEDULE OF THE WORK**

- .1 Scheduling: Refer to Section 01 00 00 – Project Specific General Requirements.

### **1.4 DELIVERY, STORAGE AND HANDLING**

- .1 Deliver, store and handle materials in accordance with manufacturer's written instructions.
- .2 Delivery and Acceptance Requirements: deliver materials to Site in original factory packaging, labelled with manufacturer's name and address.
- .3 Storage and Handling Requirements:
- .1 Store materials in accordance with manufacturer's recommendations.

- .2 Store and protect pipes from damage.
- .3 Replace defective or damaged materials with new.

## 1.5 MEASUREMENT FOR PAYMENT

- .1 Payment for PVC storm pipe and storm laterals shall be per linear metre (m) of pipe completed. The measurement for payment of completed pipe shall include the supply of all labour, materials and equipment for excavation, disposal of surplus or unsuitable excavated materials, shoring, dewatering, by-pass pumping, bedding, supply & installation of pipe, backfilling to grade, compaction and all incidental items.
- .2 Payment for reinforced concrete storm pipe shall be per linear metre (m). The price includes the supply and installation of storm sewer including excavation, bedding, installation of rubber gasket at each joint, backfilling, compaction and all incidental items.
- .3 Storm mains shall be measured along the centreline of the pipe continuously through manholes. In the case of storm outfalls, measurement shall be from the centre of the manhole to the end of the pipe installed. The length of installed pipe shall be measured horizontally. Storm laterals shall be measured from the center of the storm main to the end cap or connection at the property line.
- .4 Storm sewer fittings to be measured for payment on a per unit basis. The unit price includes excavation, supply and installation of fittings, bedding materials, backfill, compaction and all incidental items.
- .5 Connecting storm sewer lateral connections will be paid on a per unit basis and shall include all necessary labour, material and equipment to connect the lateral to the storm main or manhole. This shall include, where necessary, the following
  - .1 The proper tee on the main, approved saddle or proper manhole connection,
  - .2 Any necessary long sweep bends, plus any other labour and materials necessary for making the connection, and;
  - .3 Pipe end cap for new service or approved coupling when connecting to existing service.
- .6 Payment for inlet control devices (ICDs) shall be based on a unit price basis.
- .7 Measurement for payment for each reinforced concrete headwall shall be on a unit price basis. The unit price includes the supply of all labour, materials and equipment for the installation of the headwall, excavation, bedding, backfilling, compaction and all incidental items.
- .8 The unit of measurement for reinforced concrete inlet headwall complete with cutoff wall will be the number each. The price includes the supply and installation of reinforced concrete inlet headwall, cutoff wall, excavation, bedding, backfilling, compaction and all incidental items.
- .9 The unit of measurement for reinforced concrete headwall complete with outlet grate will be the number each. The price includes the supply and installation of reinforced concrete headwall, outlet grate, excavation, bedding, backfilling, compaction and all incidental items.

## 2 PRODUCTS

### 2.1 CONCRETE PIPE

- .1 Reinforced concrete pipe: to CSA A257, ASTM C76M and minimum class 65D (Class III), designed for flexible rubber gasket joints to CSA A257 and ASTM C443M.
- .2 All reinforced concrete pipe to be pre-tested prior to shipment. Minimum 3 pipe per test section. All pipe passing pre-testing to be labelled as passed or tested and documentation of the testing to accompany the delivery of the pipe.
- .3 Minimum storm sewer main diameter: 300mm
- .4 Locked-in gasket and integral bell system with flexible rubber gasket joints
- .5 Lifting holes:
  - .1 Pipe 900 mm and less diameter - no lift holes.
  - .2 Pipe greater than [900] mm diameter - lift holes not to exceed [two] in a piece of pipe.
  - .3 Supply prefabricated plugs to seal lift holes tight after installation of pipe.

### 2.2 PLASTIC PIPE

- .1 Type PSM Polyvinyl Chloride (PVC) Ribbed Pipe: to ASTM F794 and CSA B182.4.
  - .1 Ribbed PVC sizes 200 mm to 600 mm.
  - .2 Locked-in gasket and integral bell system with hydrostatic pressure of at least 100 kPa.
  - .3 Minimum storm sewer main diameter: 300mm
  - .4 Colour coded Green

### 2.3 SERVICE CONNECTIONS

- .1 Type PSM Polyvinyl Chloride (PVC) lateral pipe: To ASTM D3034 and CSA B182.2.
  - .1 Standard Dimensional Ratio (SDR): 28.
  - .2 Locked-in gasket and integral bell system.
  - .3 Minimum storm sewer service pipe diameter: 100mm
  - .4 Colour coded White
- .2 Service connections tees and fittings to PVC main: To ASTM D3034 and CSA B182.2.
  - .1 Connection to new PVC main to be PVC, Standard Dimensional Ratio (SDR): 35 with a locked-in gasket and integral bell system.
  - .2 Connection to existing PVC main to be "Inserta-Tee" To ASTM F477 and ASTM D3212 or "Quick Seal" or "EZ-Tee" with stainless steel clamp to ASTM C 923 complete with locked-in gaskets.
  - .3 Bends shall be of the long radius type only.

- .3 Service connections tees to reinforced concrete main: To ASTM F477 and ASTM D3212.
  - .1 Connection to reinforced concrete main to be "Inserta-Tee" or "Quick Seal" or "EZ-Tee" with stainless steel clamp to ASTM C 923 complete with locked-in gaskets

## 2.4 COUPLINGS

- .1 Couplings connecting ribbed PVC to ribbed PVC:
  - .1 Fabricated fittings certified ASTM F794 and CSA B182.4.
  - .2 Removable gasket and integral to coupling.
- .2 Couplings connecting dissimilar pipe:
  - .1 Flexible rubber repair coupling.
  - .2 Stainless steel bands with stainless steel shear ring.
  - .3 Acceptable Products:
    - .1 Fernco.
    - .2 Mission.
    - .3 Indiana Steel.
    - .4 Approved Equal.

## 2.5 PIPE INSULATION

- .1 Insulation for storm sewer mains and laterals shall be a 50 mm thick Styrofoam insulation board:
  - .1 Acceptable Products:
    - .1 Dow HI40.
    - .2 Owens Corning Formular 400.
    - .3 Approved Equal.

## 2.6 BEDDING

- .1 Granular bedding material for ribbed PVC pipe to Section 31 05 16 - Aggregate Materials and following requirements:
  - .1 Crushed or screened stone.
- .2 Granular bedding material for reinforced concrete pipe to Section 31 05 16 - Aggregate Materials and following requirements:
  - .1 Pit run gravel, screened pit run or crushed rock.
  - .2 Compacted to 95 % standard proctor density for under pavement or sidewalks.
  - .3 Compacted to 90 % standard proctor density for grassed areas.

## 2.7 BACKFILL MATERIAL

- .1 Selected backfill in accordance with Section 32 11 23 - Aggregate Placement and subbase and base in accordance with Section 31 23 33.01 - Excavating, Trenching and Backfilling.
- .2 Unshrinkable fill: to Section 31 23 33.01 - Excavating, Trenching and Backfilling.

### **3 EXECUTION**

#### **3.1 EXAMINATION**

- .1 Verification of conditions: verify that conditions of substrate previously installed under other Contracts are acceptable for storm sewer pipe installation in accordance with manufacturer's written instructions.
- .2 Visually inspect substrate in presence of Owner or Consultant.
- .3 Inform Owner or Consultant of unacceptable conditions immediately upon discovery.
- .4 Proceed with installation only after unacceptable conditions have been remedied.

#### **3.2 PREPARATION**

- .1 Clean pipes, fittings and appurtenances of accumulated debris and water before installation:
  - .1 Inspect materials for defects to approval of Owner or Consultant.
  - .2 Remove defective materials from Site as directed by Owner or Consultant.

#### **3.3 TRENCHING**

- .1 Do trenching work in accordance with Section 31 23 33.01 - Excavating, Trenching and Backfilling.
- .2 Protect trench from contents of storm sewer or storm sewer connection.
- .3 Trench alignment and depth require approval of Owner or Consultant prior to placing bedding material and pipe.

#### **3.4 GRANULAR BEDDING**

- .1 Place granular bedding materials in uniform layers not exceeding 150 mm thickness to depth of 150 mm below invert of pipe.
- .2 Do not place material in frozen condition and do not place material in a frozen trench.
- .3 Shape bed true to grade to provide continuous, uniform bearing surface for pipe.
  - .1 Do not use blocks when bedding pipe.
- .4 Shape transverse depressions in bedding as required to suit joints.
- .5 Hand place bedding material in uniform layers not exceeding 150 mm thickness as

indicated.

- .1 Do not dump material directly onto pipe.
- .6 Place layers uniformly and simultaneously on each side of pipe.
- .7 Place each layer from bottom of trench to haunch line of pipe and chink to underside of pipe.
- .8 For pit run bedding on reinforced concrete pipe, compact each layer as required in section 2.06.
- .9 Place each layer from haunch line of pipe to underside of backfill.
- .10 Fill excavation below bottom of specified bedding adjacent to manholes or structures with bedding material.
- .11 Fill authorized or unauthorized excavation below design elevation of bottom of specified bedding in accordance with Section 31 23 33.01 – Excavation, Trenching and Backfilling with compacted pit run gravel or approved equal.
- .12 Prior to placing backfill, install filter fabric from top of screened stone bedding to full width of trench.

### **3.5 BACKFILL**

- .1 Place selected backfill, subbase and base materials, above pipe bedding in uniform layers not exceeding 150 mm compacted thickness up to grades as indicated.
- .2 Do not place backfill material in frozen condition.
- .3 Under asphalt and sidewalks, compact backfill to at least 95% standard proctor density.
  - .1 In other grassed areas, compact to at least 90% standard proctor density.

### **3.6 PIPE INSTALLATION**

- .1 Handle pipe using methods approved by Owner or Consultant.
  - .1 Do not use chains or cables passed through rigid pipe bore so that weight of pipe bears upon pipe ends.
- .2 Lay pipes on prepared bed, true to line and grade, with pipe invert smooth and free of sags or high points.
  - .1 Ensure barrel of each pipe is in contact with shaped bed throughout its full length.
- .3 Begin laying at outlet and proceed in upstream direction with bell ends of pipe facing upgrade.
- .4 Joint deflection permitted within limits recommended by pipe manufacturer.
- .5 Tension rod/bar assemblies shall be required on all reinforced concrete outlet ends that do not terminate at a structure and are greater than 3% grade.
- .6 Tension rod/bar assemblies shall be supplied as indicated in NBDTI Standard Drawing 140-1 for pipes specifically identified in the Contract Documents.

- .7 Tension rod/bar assemblies shall be installed as indicated in NBDTI Standard Drawing 140-1 and in the Contract Documents.
- .8 Water not to flow through pipe during construction, unless permitted Owner or Consultant.
- .9 Whenever Work is suspended, install removable watertight bulkhead at open end of last pipe laid to prevent entry of foreign materials.
- .10 Install plastic pipe and fittings in accordance with CSA B182.11.
- .11 Pipe jointing:
  - .1 Install gaskets in accordance with manufacturer's written recommendations.
  - .2 Support pipes with hand slings or crane as required to minimize lateral pressure on gasket and maintain concentricity until gasket is properly positioned.
  - .3 Align pipes before joining.
  - .4 Maintain pipe joints free from mud, silt, gravel and foreign material.
  - .5 Avoid displacing gasket or contaminating with dirt or foreign material. Gaskets so disturbed to be removed, cleaned and lubricated and replaced before joining is attempted.
  - .6 Complete each joint and place bedding before laying next length of pipe.
  - .7 Minimize joint deflection after joint has been made to avoid joint damage.
  - .8 At rigid structures, install pipe joints not more than 1.2 m from side of structure.
  - .9 Apply sufficient pressure in making joints to ensure that joint is complete as outlined in manufacturer's recommendations.
- .12 When stoppage of Work occurs, support pipes as directed by Owner or Consultant to prevent creep during down time.
- .13 Plug lifting holes with prefabricated plugs or grout approved by Owner or Consultant.
- .14 Cut pipes as required for special inserts, fittings or closure pieces as recommended by pipe manufacturer, without damaging pipe or its coating and to leave smooth end at right angles to axis of pipe.
- .15 Make watertight connections to manholes.
- .16 Use prefabricated couplings for field connections approved by Owner or Consultant for connecting pipes to existing storm sewer pipes of same material.
  - .1 Joints to be structurally sound and watertight.
- .17 When connecting dissimilar storm sewer pipe materials, use a flexible rubber repair coupling, with stainless steel bands and stainless-steel sheer ring.

### **3.7 SERVICE CONNECTIONS**

- .1 Install pipe to manufacturer's instructions and specifications.
- .2 Maintain grade for 100 mm diameter storm sewers at 1 % minimum unless directed by Owner or Consultant.
- .3 Service connections to main storm sewer: Fabricated PVC Tee fitting for ribbed pipe

connection and Inserta-Tee for Concrete pipe connection.

- .1 Do not use break-in and mortar patch-type joints.
- .4 Service connection pipe: not to extend into interior of main storm sewer.
- .5 Make up required horizontal and vertical bends from 45 degrees bends or less, separated by straight section of pipe with minimum length of 4 pipe diameters.
  - .1 Use long sweep bends where applicable.
- .6 Plug service laterals with watertight caps or plugs.
- .7 Place location marker at ends of plugged or capped unconnected storm sewer lines.
  - .1 Each marker: 38 x 89 mm stake extending from pipe end at pipe level to 600 mm above finished grade in grassed areas and 600 mm below finished grade in asphalt areas to locate pipe end.
  - .2 Paint exposed portion of stake pink with designation ST SWR LINE in black.

### **3.8 FIELD TESTING**

- .1 All storm sewers to be flushed and videoed.
- .2 Remove foreign material from storm sewers and related appurtenances by flushing with water.
  - .1 Flushing to be completed with high pressure flushing equipment capable of removal and collection of debris.
  - .2 All debris is to be collected and prevented from entering other sections of storm sewer mains outside the Work area.
- .3 All storm sewers to be video inspected:
  - .1 All CCTV work shall conform to National Association of Sewer Service Companies (NASSCO) – Pipeline Assessment Certification Program (PACP) standards.
  - .2 Camera Operator shall be a PACP certified operator and proof of certification shall be submitted to the Owner or Consultant prior to starting CCTV.
  - .3 Storm sewers to be videoed with coloured closed-circuit television inspection (CCTV) from manhole to manhole.
  - .4 Camera shall be capable of tilt and pan.
  - .5 Camera shall pause, tilt and pan at all end pipes, service lateral connections, pipe defects, sags, etc.
  - .6 All inspections shall accurately measure linear distance. Measurements shall be accurately displayed in the videos.
  - .7 All videos and pdf video inspection reports are to be submitted to the Owner or Consultant at the completion of the Work.
  - .8 No asphalt restoration is to be completed until videos and reports have been submitted and reviewed by the Owner or Consultant.
  - .9 All defects identified in the videos and reports are to be corrected prior to asphalt

restoration.

### **3.9 CLEANING**

- .1 Refer to Section 01 00 00 – Project Specific General Requirements.

**END OF SECTION**

## **1 GENERAL**

### **1.1 DESCRIPTION**

- .1 This Section specifies the requirements for supplying and installing various diameters of pipe culverts. Work includes excavation, supply and installation of pipe, fittings, bedding materials, backfill and compaction of pipe as shown on the associated drawings.

### **1.2 REFERENCE STANDARDS**

- .1 ASTM C76M-22a, Standard Specification for Reinforced Concrete Culvert, Storm Drain, and Sewer Pipe (Metric).
- .2 ASTM C443M-21, Standard Specification for Joints for Concrete Pipe and Manholes, Using Rubber Gaskets (Metric).
- .3 ASTM D3034-21, Standard Specification for Type PSM Poly(Vinyl Chloride) (PVC) Sewer Pipe and Fittings.
- .4 ASTM D3212-21, Standard Specification for Joints for Drain and Sewer Plastic Pipes Using Flexible Elastomeric Seals.
- .5 ASTM F477-14(2021), Standard Specification for Elastomeric Seals (Gaskets) for Joining Plastic Pipe.
- .6 ASTM F794-21, Standard Specification for Poly(Vinyl Chloride) (PVC) Profile Gravity Sewer Pipe and Fittings Based on Controlled Inside Diameter.
- .7 CSA A257 Series:19, Standards for Concrete Pipe and Manhole Sections.
- .8 CSA B1800;21, Thermoplastic Nonpressure Piping Compendium (Standard CSA B182.2).
- .9 CSA B1800;21, Thermoplastic Nonpressure Piping Compendium (Standard CSA B182.4).
- .10 CSA B1800;21, Thermoplastic Nonpressure Piping Compendium (Standard B182.11).

### **1.3 SCHEDULE OF THE WORK**

- .1 Scheduling: Refer to Section 01 00 00 – Project Specific General Requirements.

### **1.4 DELIVERY, STORAGE AND HANDLING**

- .1 Deliver, store and handle materials in accordance with manufacturer's written instructions.
- .2 Delivery and Acceptance Requirements: deliver materials to Site in original factory packaging, labelled with manufacturer's name and address.
- .3 Storage and Handling Requirements:
- .1 Store materials in accordance with manufacturer's recommendations.
  - .2 Store and protect pipes from damage.

- .3 Replace defective or damaged materials with new.

## 1.5 MEASUREMENT FOR PAYMENT

- .1 Payment for pipe culvert shall be per linear metre (m) of each size, type and class of pipe. The measurement for payment of pipe culvert shall include the supply of all labour, materials and equipment for excavation, disposal of surplus or unsuitable excavated materials, shoring, dewatering, by-pass pumping, bedding, supply & installation of pipe, backfilling to grade, compaction and all incidental items.
- .1 No separate measurement will be made for couplings and fittings for steel pipe and plastic pipe culverts.
- .2 Pipe culverts shall be measured horizontally along the centreline of the pipe.
- .3 Measurement for payment for each reinforced concrete headwall shall be on a unit price basis. The unit price includes the supply of all labour, materials and equipment for the installation of the headwall, excavation, bedding, backfilling, compaction and all incidental items.
- .4 The unit of measurement for reinforced concrete inlet headwall complete with cutoff wall will be the number each. The price includes the supply and installation of reinforced concrete inlet headwall, cutoff wall, excavation, bedding, backfilling, compaction and all incidental items.
- .5 The unit of measurement for reinforced concrete headwall complete with outlet grate will be the number each. The price includes the supply and installation of reinforced concrete headwall, outlet grate, excavation, bedding, backfilling, compaction and all incidental items.

## 2 PRODUCTS

### 2.1 CONCRETE PIPE

- .1 Reinforced concrete pipe: to CSA A257, ASTM C76M and minimum class 65D (Class III), designed for flexible rubber gasket joints to CSA A257 and ASTM C443M.
- .2 All reinforced concrete pipe to be pre-tested prior to shipment. Minimum 3 pipe per test section. All pipe passing pre-testing to be labelled as passed or tested and documentation of the testing to accompany the delivery of the pipe.
- .3 Locked-in gasket and integral bell system with flexible rubber gasket joints
- .4 Lifting holes:
- .1 Pipe 900 mm and less diameter - no lift holes.
- .2 Pipe greater than [900] mm diameter - lift holes not to exceed [two] in a piece of pipe.
- .3 Supply prefabricated plugs to seal lift holes tight after installation of pipe.

### 2.2 PLASTIC PIPE

- .1 Type PSM Polyvinyl Chloride (PVC) Ribbed Pipe: to ASTM F794 and CSA B182.4.
  - .1 Ribbed PVC sizes 200 mm to 600 mm.
  - .2 Locked-in gasket and integral bell system with hydrostatic pressure of at least 100 kPa.
  - .3 Colour coded Green

### 2.3 ACCEPTABLE PRODUCT WHEN APPROVED BY OWNER

- .1 Corrugated Polyethylene pipe and fittings
  - .1 Corrugated Polyethylene Pipe and fittings: to CSA B182.8
  - .2 Minimum pipe stiffness: 320 kPa
  - .3 Pipe to be double walled with a smooth interior surface and corrugated exterior surface
  - .4 Connections: split coupling which covers at least two corrugations of each pipe end
- .2 Corrugated Steel pipe
  - .1 Corrugated Steel Pipe: To CAN/CSA G401.
  - .2 Water-tight cut-off collars: as indicated.
  - .3 Prefabricated end sections or wing walls: as indicated.
  - .4 Corrugated fluming: to CAN/CSA-G401.

### 2.4 PIPE INSULATION

- .1 Insulation for storm sewer mains and laterals shall be a 50 mm thick Styrofoam insulation board:
  - .1 Acceptable Products:
    - .1 Dow HI40.
    - .2 Owens Corning Formular 400.
    - .3 Approved Equal.

### 2.5 GRANULAR BEDDING

- .1 Granular bedding material for ribbed PVC pipe to Section 31 05 16 - Aggregate Materials and following requirements:
  - .1 Crushed or screened stone.
- .2 Granular bedding material for reinforced concrete pipe to Section 31 05 16 - Aggregate Materials and following requirements:
  - .1 Pit run gravel, screened pit run or crushed rock.
  - .2 Compacted to 95 % standard proctor density for under pavement or sidewalks.
  - .3 Compacted to 90 % standard proctor density for grassed areas.

## **2.6 BACKFILL MATERIAL**

- .1 Selected backfill in accordance with Section 31 24 13 – Roadway Construction, Embankments and Compaction. Base and subbase materials in accordance with Section 32 11 23 - Aggregate Placement.

## **3 EXECUTION**

### **3.1 EXAMINATION**

- .1 Verification of conditions: verify that conditions of substrate previously installed under other Contracts are acceptable for storm sewer pipe installation in accordance with manufacturer's written instructions.
- .2 Visually inspect substrate in presence of Owner or Consultant.
- .3 Inform Owner or Consultant of unacceptable conditions immediately upon discovery.
- .4 Proceed with installation only after unacceptable conditions have been remedied.

### **3.2 PREPARATION**

- .1 Clean pipes, fittings and appurtenances of accumulated debris and water before installation:
  - .1 Inspect materials for defects to approval of Owner or Consultant.
  - .2 Remove defective materials from Site as directed by Owner or Consultant.

### **3.3 TRENCHING**

- .1 Do trenching work in accordance with Section 31 23 33.01 - Excavating, Trenching and Backfilling.
- .2 Protect trench from contents of pipe culvert.
- .3 Trench alignment and depth require approval of Owner or Consultant prior to placing bedding material and pipe.

### **3.4 GRANULAR BEDDING**

- .1 Place granular bedding materials in uniform layers not exceeding 150 mm thickness to depth of 150 mm below invert of pipe culvert.
- .2 Do not place material in frozen condition and do not place material in a frozen trench.
- .3 Shape bed true to grade to provide continuous, uniform bearing surface for pipe culvert.
  - .1 Do not use blocks when bedding pipe.
- .4 Shape transverse depressions in bedding as required to suit joints.

- .5 Hand place bedding material in uniform layers not exceeding 150 mm thickness as indicated.
  - .1 Do not dump material directly onto pipe.
- .6 Place layers uniformly and simultaneously on each side of pipe culvert.
- .7 Place each layer from bottom of trench to haunch line of pipe and chink to underside of pipe.
- .8 For pit run bedding on reinforced concrete pipe, compact each layer as required in section 2.06.
- .9 Place each layer from haunch line of pipe to underside of backfill.
- .10 Fill authorized or unauthorized excavation below design elevation of bottom of specified bedding in accordance with Section 31 23 33.01 – Excavation, Trenching and Backfilling with compacted pit run gravel or approved equal.
- .11 Prior to placing backfill, install filter fabric from top of screened stone bedding to full width of trench.

### **3.5 PIPE INSTALLATION**

- .1 Handle pipe using methods approved by Owner or Consultant.
  - .1 Do not use chains or cables passed through rigid pipe bore so that weight of pipe bears upon pipe ends.
- .2 Lay pipes on prepared bed, true to line and grade, with pipe invert smooth and free of sags or high points.
  - .1 Ensure barrel of each pipe is in contact with shaped bed throughout its full length.
- .3 Begin laying at outlet and proceed in upstream direction with bell ends of pipe facing upgrade.
- .4 Joint deflection permitted within limits recommended by pipe manufacturer.
- .5 Tension rod/bar assemblies shall be required on all reinforced concrete outlet ends that do not terminate at a structure and are greater than 3% grade.
- .6 Tension rod/bar assemblies shall be supplied as indicated in NBDTI Standard Drawing 140-1 for pipes specifically identified in the Contract Documents.
- .7 Tension rod/bar assemblies shall be installed as indicated in NBDTI Standard Drawing 140-1 and in the Contract Documents.
- .8 Water not to flow through pipe during construction, unless permitted Owner or Consultant.
- .9 Whenever Work is suspended, install removable watertight bulkhead at open end of last pipe laid to prevent entry of foreign materials.
- .10 Install plastic pipe and fittings in accordance with CSA B182.11.
- .11 Pipe jointing:
  - .1 Install gaskets in accordance with manufacturer's written recommendations.
  - .2 Support pipes with hand slings or crane as required to minimize lateral pressure on

- gasket and maintain concentricity until gasket is properly positioned.
- .3 Align pipes before joining.
  - .4 Maintain pipe joints free from mud, silt, gravel and foreign material.
  - .5 Avoid displacing gasket or contaminating with dirt or foreign material. Gaskets so disturbed to be removed, cleaned and lubricated and replaced before joining is attempted.
  - .6 Complete each joint and place bedding before laying next length of pipe.
  - .7 Minimize joint deflection after joint has been made to avoid joint damage.
  - .8 At rigid structures, install pipe joints not more than 1.2 m from side of structure.
  - .9 Apply sufficient pressure in making joints to ensure that joint is complete as outlined in manufacturer's recommendations.
- .12 When stoppage of Work occurs, support pipes as directed by Owner or Consultant to prevent creep during down time.
  - .13 Plug lifting holes with prefabricated plugs or grout approved by Owner or Consultant.
  - .14 Cut pipes as required for special inserts, fittings or closure pieces as recommended by pipe manufacturer, without damaging pipe or its coating and to leave smooth end at right angles to axis of pipe.
  - .15 Use prefabricated couplings for field connections approved by Owner or Consultant for connecting pipes to existing storm sewer pipes of same material.
    - .1 Joints to be structurally sound and watertight.
  - .16 When connecting dissimilar storm sewer pipe materials, use a flexible rubber repair coupling, with stainless steel bands and stainless-steel shear ring.

### **3.6 CORRUGATED STEEL CULVERTS JOINTS**

- .1 Match corrugations or indentations of coupler with pipe sections before tightening.
- .2 Tap couplers firmly as they are being tightened, to take up slack and ensure snug fit.
- .3 Insert and tighten bolts.
- .4 Repair spots where damage has occurred to spelter coating by using method approved by Owner or Consultant.
- .5 Structural plate: erect in final position by connecting plates with bolts at longitudinal and circumferential seams.

### **3.7 BACKFILL MATERIAL**

- .1 Place selected backfill, subbase and base materials, above pipe bedding in uniform layers not exceeding 150 mm compacted thickness up to grades as indicated.
- .2 Do not place backfill material in frozen condition.
- .3 Under asphalt and sidewalks, compact backfill to at least 95% standard proctor density.

- .1 In other grassed areas, compact to at least 90% standard proctor density.

### **3.8 CLEANING**

- .1 Refer to Section 01 00 00 – Project Specific General Requirements.

**END OF SECTION**

## **1 GENERAL**

### **1.1 DESCRIPTION**

- .1 This Section specifies the requirements for supplying and installing steel W-beam guide rail. Work includes excavation, supply and installation of wooden posts, wooden offset posts, hardware, steel w-beam sections and terminal sections of w-beam as shown on the associated drawings.

### **1.2 REFERENCE STANDARDS**

- .1 AASHTO M180-18 (2021), Standard Specification for Corrugated Sheet Steel Beams for Highway Guardrail.
- .2 ASTM A123/A123M-17, Standard Specification for Zinc (Hot-Dip Galvanized) Coatings on Iron and Steel Products.
- .3 ASTM A307-21, Standard Specification for Carbon Steel Bolts, Studs, and Threaded Rod 60 000 PSI Tensile Strength.
- .4 CAN/CSA O80 Series:21, Wood Preservation.

### **1.3 ADMINISTRATIVE REQUIREMENTS**

- .1 Scheduling: Refer to Section 01 00 00 – Project Specific General Requirements.
- .1 Schedule Work to minimize interruptions to existing services and maintain existing traffic during construction.
- .2 Submit schedule of expected interruptions for approval and adhere to approved schedule.
- .3 Notify Owner or Consultant 24 hours minimum in advance of any interruption in service.

### **1.4 DELIVERY, STORAGE AND HANDLING**

- .1 Deliver, store and handle materials in accordance with manufacturer's written instructions.
- .2 Delivery and acceptance requirements: deliver materials to Site in original factory packaging, labelled with manufacturer's name and address.
- .3 Storage and handling requirements:
- .1 Store materials in accordance with manufacturer's recommendations.
- .2 Store and protect pipes from damage.
- .3 Replace defective or damaged materials with new.

## **1.5 MEASUREMENT FOR PAYMENT**

- .1 Payment for guide rail shall be made per lineal metre (m) of guide rail supplied and installed in accordance with this Item. All hardware to be included in the guide rail unit price.
- .2 Payment for guide rail posts shall be made under a unit price basis for the number of guide rail posts supplied and installed in accordance with this Item. Price shall include the removal and reinstallation of existing guide rail.

## **2 PRODUCTS**

### **2.1 MATERIALS**

- .1 Steel W-beam guide rail as indicated and as follows:
  - .1 Steel rail and terminal sections: to AASHTO M180, class A, Type 2 zinc coated.
  - .2 Bolts, nuts and washers: to ASTM A307, hot dip galvanized to ASTM A123/A123M.
- .2 Sawn timber posts and offset blocks:
  - .1 Species: Maple, birch or beech hardwood.
  - .2 Type: pressure treated in accordance with CAN/CSA-O80 Series.
  - .3 Grade: No. 1.
  - .4 Dimensions: as indicated.

## **3 EXECUTION**

### **3.1 EXAMINATION**

- .1 Verification of conditions: verify that conditions of substrate previously installed under other Sections or Contracts are acceptable for guide rail installation in accordance with manufacturer's written instructions.
  - .1 Visually inspect substrate in presence of Owner or Consultant.
  - .2 Inform Owner or Consultant of unacceptable conditions immediately upon discovery.
  - .3 Proceed with installation only after unacceptable conditions have been remedied.

### **3.2 PREPARATION**

- .1 Temporary erosion and sedimentation control:
  - .1 Supply and install temporary erosion and sedimentation control measures to prevent soil erosion and discharge of soil-bearing water runoff or airborne dust to adjacent properties and walkways, as per requirements of authorities having jurisdiction.

- .2 Inspect, repair, and maintain erosion and sedimentation control measures during construction until permanent vegetation has been established.
- .3 Remove erosion and sedimentation controls and restore and stabilize areas disturbed during removal.

### **3.3 ERECTION**

- .1 Set posts by instrument for alignment, and locations as indicated.
- .2 Excavate post holes to depths as indicated and to diameter of 360 mm plus or minus 20 mm.
  - .1 Compact bottom to provide firm foundation.
  - .2 Set post plumb and square in hole.
  - .3 Backfill around posts using excavated material and compact in uniform layers not exceeding 150 mm compacted thickness.
  - .4 Cut off tops of posts as indicated, with tops parallel to grade of pavement edge.
  - .5 Worker protection: ensure workers wear gloves, respirators, dust masks, long sleeved clothing, eye protection and protective clothing when handling, drilling, sawing, cutting or sanding preservative treated wood and applying preservative materials.
  - .6 Treat cut tops with 2 coats of preservative.
  - .7 Construct anchorages to details as indicated.
    - .1 Place and compact backfill for anchors as indicated on the Drawings.
  - .8 Erect steel W-beam components to details as indicated. Lap joints in direction of traffic.
    - .1 Tighten nuts to 100 N.m torque.
      - .1 Maximum protrusion of bolt 12 mm beyond nut.

### **3.4 CLEANING**

- .1 Progress Cleaning: Leave Work area clean at end of each day.
- .2 Final Cleaning: upon completion remove surplus materials, rubbish, tools and equipment.

### **3.5 PROTECTION**

- .1 Protect installed products and components from damage during construction.
- .2 Repair damage to adjacent materials caused by guide rail installation.

**END OF SECTION**

# APPENDIX A ADDITIONAL TECHNICAL SPECIFICATIONS



	<b>No. of Pages</b>
<b>APPENDIX A – ADDITIONAL TECHNICAL SPECIFICATIONS .....</b>	<b>6</b>
A.1 Asphalt Pulverization	
A.2 Ditching	
A.3 High shoulder Removal	
A.4 Repairs to Existing Sewer Service Pipes and Appurtenances	

**END OF SECTION**

## **A.1 ASPHALT PULVERIZATION**

### **1 GENERAL**

#### **1.1 DESCRIPTION**

- .1 This section specifies the requirements for pulverizing, reshaping and compacting of a Roadbed surface as shown on the associated drawings.

#### **1.2 MEASUREMENT FOR PAYMENT**

- .1 Pulverizing and reshaping existing asphalt pavement will be measured in square metres.  
.2 New granular base material used while reshaping existing asphalt will be measured in tonnes of material incorporated into Work.

### **2 PRODUCTS**

#### **2.1 MATERIALS**

- .1 Granular base: material in accordance with Section 31 05 16 - Aggregate Materials.

#### **2.2 EQUIPMENT**

- .1 Compaction equipment must be capable of obtaining required densities in materials on project.

### **3 EXECUTION**

#### **3.1 EXAMINATION**

- .1 Verification of conditions: verify that conditions of substrate previously installed under other Sections or Contracts are acceptable for guide rail installation in accordance with manufacturer's written instructions.
- .1 Visually inspect substrate in presence of Owner or Consultant.
  - .2 Inform Owner or Consultant of unacceptable conditions immediately upon discovery.
  - .3 Proceed with installation only after unacceptable conditions have been remedied.

#### **3.2 PULVERIZING AND RESHAPING**

- .1 Pulverization shall be carried out to the existing asphalt roadway width. The depth of pulverization shall be 150mm± /or as specifically directed by the Engineer.
- .2 Blade and trim pulverized pavement material to elevation and cross section dimensions directed by Owner or Consultant.
- .3 Where deficiency of pulverized material exists, add and blend in new granular base material as directed by Owner or Consultant. Do not use frozen material.
- .4 Asphalt pulverizing shall be removed in accordance with the NBDTI Standard Specification Item No. 267 Pulverizing.
- .5 The Contractor shall ensure that this pulverized region is in a completely mixed and loosened condition, with all material sized such that 100% of the material passes the 75 mm sieve, when measured in accordance with ASTM C136.
- .6 The Contractor shall carry out the Work as indicated in the Contract Documents and/or as specifically directed by the Engineer.
- .7 Every street shall be proof rolled after pulverizing. Load testing shall be done by having a fully loaded tandem truck travel the length of roadway. If deflection is greater than 5mm, sub-base or base shall be removed, or extra gravel shall be imported as directed by the Engineer.
- .8 Oversize pieces (chunks) remaining after pulverizing shall be disposed of outside the Work Site.
- .9 The re-graded surface material shall be compacted in accordance with NBDTI Item 936 to a minimum of 95% of the maximum dry density.
- .10 Final shaping of the pulverized surface shall be in accordance with NBDTI Item 941 and shall not vary by more than 30 mm from the grades provided by the Engineer.

### **3.3 COMPACTING**

- .1 Compact reshaped material in accordance with written approval of Owner or Consultant.
- .2 Shape and roll alternately to obtain smooth, even and uniformly compacted base.
- .3 Apply water as necessary during compacting.

### **3.4 FINISH TOLERANCES**

- .1 Reshape surface to within plus or minus [10] mm of elevation as indicated, but not uniformly high or low.
- .2 Correct surface irregularities by loosening and adding or removing material until surface is within specified tolerance.

### **3.5 CLEANING**

- .1 Progress Cleaning: in accordance with Section 01 00 00 – Project Specific General Requirements.

- .2 Final Cleaning: in accordance with Section 01 00 00 – Project Specific General Requirements.

### **3.6 PROTECTION**

- .1 Protect and maintain reshaped asphalt pavement surface in condition conforming to this section until succeeding material is applied or until after receipt of written acceptance from Owner or Consultant.

### **A.2 DITCHING**

## **1 GENERAL**

### **1.1 DESCRIPTION**

- .1 This section specifies requirements for ditch excavation and ditch cleaning at various locations in Quispamsis as shown on the accompanying drawings and/or as ordered, all in accordance with this specification. This section shall also include brush removal and the grubbing of existing shoulders and foreslopes of existing roadways to permit roadway widening as well as the excavation of existing driveway culverts on various roads not located within the excavation boundaries of the trench.

### **1.2 DEFINITIONS**

- .1 Ditch Excavation
- .1 Ditch excavation shall consist of excavating all material encountered including organics, sandstone, bituminous pavement and existing pipe within the ditch limits. Dimensions shall be approximately 0.75m deep by 3m wide.
- .2 Ditch Cleaning
- .2 Ditch cleaning shall consist of shaping and/or minor excavating all material encountered including organics, sandstone, bituminous pavement and debris within the ditch limits. Dimension varies on existing ditches.

### **1.3 MEASUREMENT FOR PAYMENT**

- .1 Ditch Excavation will be paid by the number of lineal meters of successfully excavated ditch as approved by the Engineer on site.
- .2 Ditch Cleaning will be paid by the number of lineal meters of successfully shaped and

cleaned ditch as approved by the Engineer on site.

.3 Work which will not be measured for payment, but shall be considered as incidental to the work shall include but not be limited to:

.1 a) disposal of surplus waste material;

.2 b) disposal of brush;

.3 c) salvage and transport to Town yard of pipe deemed suitable for reuse.

## **2 EXECUTION**

.1 The Contractor shall cut, excavate and/or clean ditches as shown on the drawings or as directed by the Engineer.

.2 Ditch excavation shall consist of excavating all material within the ditch limits.

.3 Unclassified Excavation, glacial till, boulder clay, broken stone, bituminous pavement and existing pipe and structures where required will be classified as ditch Excavation.

.4 Where ditches exist but require remediation, clean-up will be required to remove debris, silt build up, flat areas and other locations where feasible.

### **A.3 HIGH SHOULDER REMOVAL**

## **1 GENERAL**

### **1.1 DESCRIPTION**

.1 This section specifies the requirements for the removal of material built up on the shoulders.

### **1.2 MEASUREMENT FOR PAYMENT**

.1 The number of lineal meters of shoulders excavated and build up removed in the completed and accepted work as measured on the site by the Engineer.

## **2 EXECUTION**

.1 Excavate all material within the limits of the road shoulder which constricts the movement of surface water off the roadway. The excess material shall be removed

by excavator or grader to allow the newly placed asphalt cap or asphalt structure to drain properly. This excess material shall be removed after the street is paved. This material shall be removed, hauled and disposed of at the approved disposal site.

#### **A.4 REPAIRS TO EXISTING SEWER SERVICE PIPES AND APPURTENANCES**

### **1 GENERAL**

#### **1.1 DESCRIPTION**

- .1 This Section includes the requirements for supplying and installing various types and sizes of service pipe and fittings for sanitary or storm sewers not shown on the drawings and/or as ordered all in accordance with this specification.

#### **1.2 MEASUREMENT FOR PAYMENT**

- .1 Connections to existing service pipes to include water tight connections between the new service pipe and the existing service pipe where required and will not be measured for payment.
- .2 Measurement for payment for repair of unmarked existing service pipes will be paid on a per unit basis. The price shall include all labour, materials and equipment required to facilitate the repair.
- .3 No payment will be made for the repair of existing service pipes which are located within two (2) metres either side of marked location.
- .4 Measurement for payment for connecting existing drain tile to new storm sewer or extending drain tile piping to new ditch will be paid on a per unit basis. The price shall include all labour, materials and equipment required to connect existing drain tile to new storm sewer or extend drain tile to new ditch.

### **2 MATERIALS**

- .1 Sewer piping material to be in accordance with Division 33 Utilities.

### **3 EXECUTION**

### 3.1 BEDDING AND BACKFILLING

- .1 Bedding and backfilling of the sewer service pipes shall be in accordance with Section 31 23 33 – Excavating, Trenching and Backfilling.

### 3.2 REPAIR OF EXISTING SERVICE PIPE

- .1 It shall be the Contractor's responsibility to have the Owner locate existing sanitary and storm sewer service pipes in areas affected by the work prior to commencing construction.
  - .1 Should the Contractor damage any pipe which is located within two (2) metres either side of the marked location indicated by the Owner, the Contractor shall repair the service pipe at his expense including the supply of all necessary pipe and fittings required to facilitate the repair.
  - .2 Should the Contractor encounter and damage an existing service pipe which is **unmarked** or located more than two (2) metres either side of the indicated service location, the Contractor shall repair the service as directed including the supply of all necessary pipe and fittings required to facilitate the repair.
- .2 Should the Contractor neglect to have the Owner locate existing services, the Contractor shall repair damages to unmarked services at his expense including the supply of all necessary pipe and fittings required to facilitate the repair.

### 3.3 CONNECTING EXISTING DRAIN TILE TO NEW STORM SEWER OR EXTENDING DRAIN TILE TO NEW DITCH

- .1 When the elevation of existing drain tiles are finish, grade, and/or when directed by the Engineer, the Contractor shall connect the existing drain tile pipe into the new storm sewer system.
- .2 The Contractor shall connect the drain tile pipe to the storm sewer pipe, or adjacent precast structure using approved service connection fittings, designed for the size and type of pipe at hand.
- .3 The Contractor shall supply all labor, tools, service connection fittings, flexible transition coupling bends and up to 4.0 lineal metres of new PVC DR35 service pipe.
- .4 If a drain tile connection is greater than 4.0 lineal metres in length, excess pipe will be measured and paid for under Section 33 41 00 – Storm Sewer Piping at the contract unit price.

**END OF SECTION**

# PART III

## STANDARD DETAILS

**PART III – STANDARD DETAILS**

<b>Detail No.</b>	<b>Title</b>	
31.SD01	Sediment Control Fence.....	1
31.SD02	Sediment Control Berm .....	1
31.SD03	Sediment Settling Pond .....	1
32.SD01	Utility Restoration Asphalt Concrete T Patch .....	1
32.SD02	Concrete Curb and Gutter .....	1
32.SD03	Concrete Curb and Gutter and Sidewalk .....	1
32.SD03A	Driveway Entrance with Concrete Curb and Gutter and Sidewalk.....	1
32.SD04	Sidewalk Access Ramps.....	1
32.SD05	Chain Link Fence .....	1
32.SD06	Chain Link Security Gate with Vehicle Gate .....	1
32.SD07	Typical Urban Road Cross Section .....	1
32.SD08	Typical Rural Road Cross Section.....	1
32.SD09	Cul-De-Sac.....	1
32.SD10	Angle Intersection .....	1
33.SD01	Single Pipe Trench .....	1
33.SD02	Two Pipe Trench .....	1
33.SD03	Three Pipe Trench .....	1
33.SD03A	Rock Trench Payment Limits .....	1
33.SD04	Fire Hydrant .....	1
33.SD05	MVB Composite Adjustable Valve Box (105mm & 130mm) .....	1
33.SD06	Gate Valve and Chamber .....	1
33.SD07	Tracer Wire Detail .....	1
33.SD08	Chlorination and Flushing.....	1
33.SD09	Concrete Thrust Blocks.....	1
33.SD10	Air Release Valve Chamber .....	1
33.SD11	Water Service Connection .....	1
33.SD12	Valve Chamber Standard Frame and Cover.....	1
33.SD13	Valve Chamber Adjustable Frame and Cover .....	1
33.SD14	Sanitary Manhole.....	1
33.SD15	Interior Drop Manhole .....	1
33.SD16	Sanitary Service Connection .....	1
33.SD17	Standard Sanitary Manhole Frame and Cover .....	1

33.SD18	Sanitary Manhole Adjustable Frame and Cover .....	1
33.SD19	Storm Manhole .....	1
33.SD20	Catch Basin .....	1
33.SD21	Catch Basin at Curb-Curb Gutter.....	1
33.SD22	Storm Service Connection .....	1
33.SD23	Storm Manhole Standard Frame and Cover .....	1
33.SD24	Storm Manhole Adjustable Frame and Cover .....	1
33.SD25	Catch Basin Standard Frame and Flat Grate .....	1
33.SD26	Catch Basin Pyramid Frame and Cover .....	1
33.SD27	Culvert Inlet Grate .....	1
33.SD28	Culvert Outlet Grate.....	1
33.SD29	Pipe Insulation Cover Less Than 1.8m .....	1
34.SD01	Collector 1 – Urban (2 Lane) .....	1
34.SD02	Collector 1 – Urban (3 Lane) with AT Trail.....	1
34.SD03	Collector 1 – Urban (4 Lane) .....	1
34.SD04	Collector 2 – Rural (AADT < 5000).....	1
34.SD05	Collector 2 – Rural (AT Route ≥ 5000 AADT).....	1
34.SD06	Minor Collector (Curbed) .....	1
34.SD07	Minor Collector (Curbed) with Bike Lanes .....	1
34.SD08	Minor Collector (Non-Curbed).....	1
34.SD09	Minor Collector (Non-Curbed AT).....	1
34.SD10	Local.....	1
34.SD11	Local (AT) .....	1
34.SD12	Guide Rail.....	1
34.SD13	Guide Rail termination .....	1

**END OF SECTION**

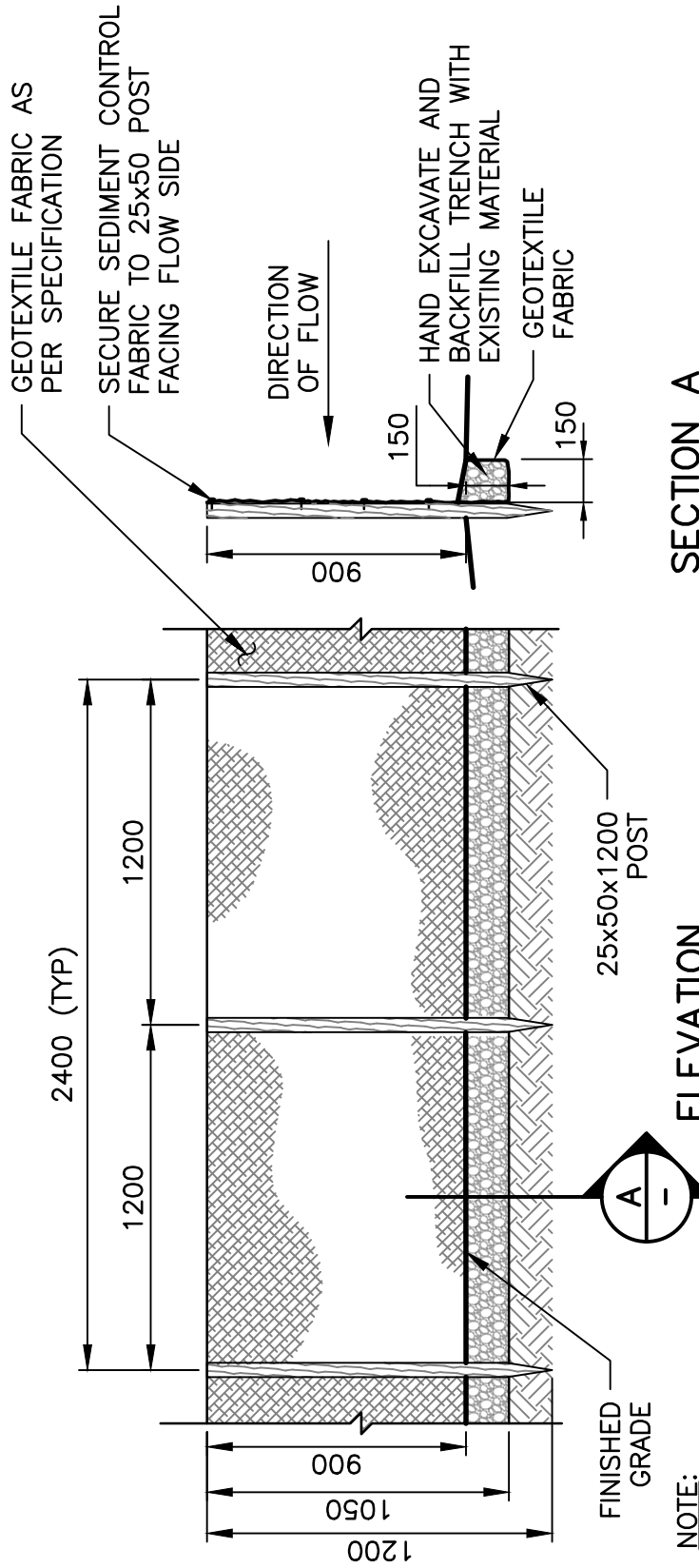

**SECTION A**

**ELEVATION**

**NOTE:**

- EROSION CONTROL MEASURES AROUND PERIMETER OF EACH SITE TO INCLUDE SILT FENCE

No.	Description	No.	Description	No.	Description
Date	2021-01-21	Scale	1:25	Drawn	THM
			TOWN OF QUISPAMISIS SEDIMENT CONTROL FENCE		Drawing <b>31.SD01</b>

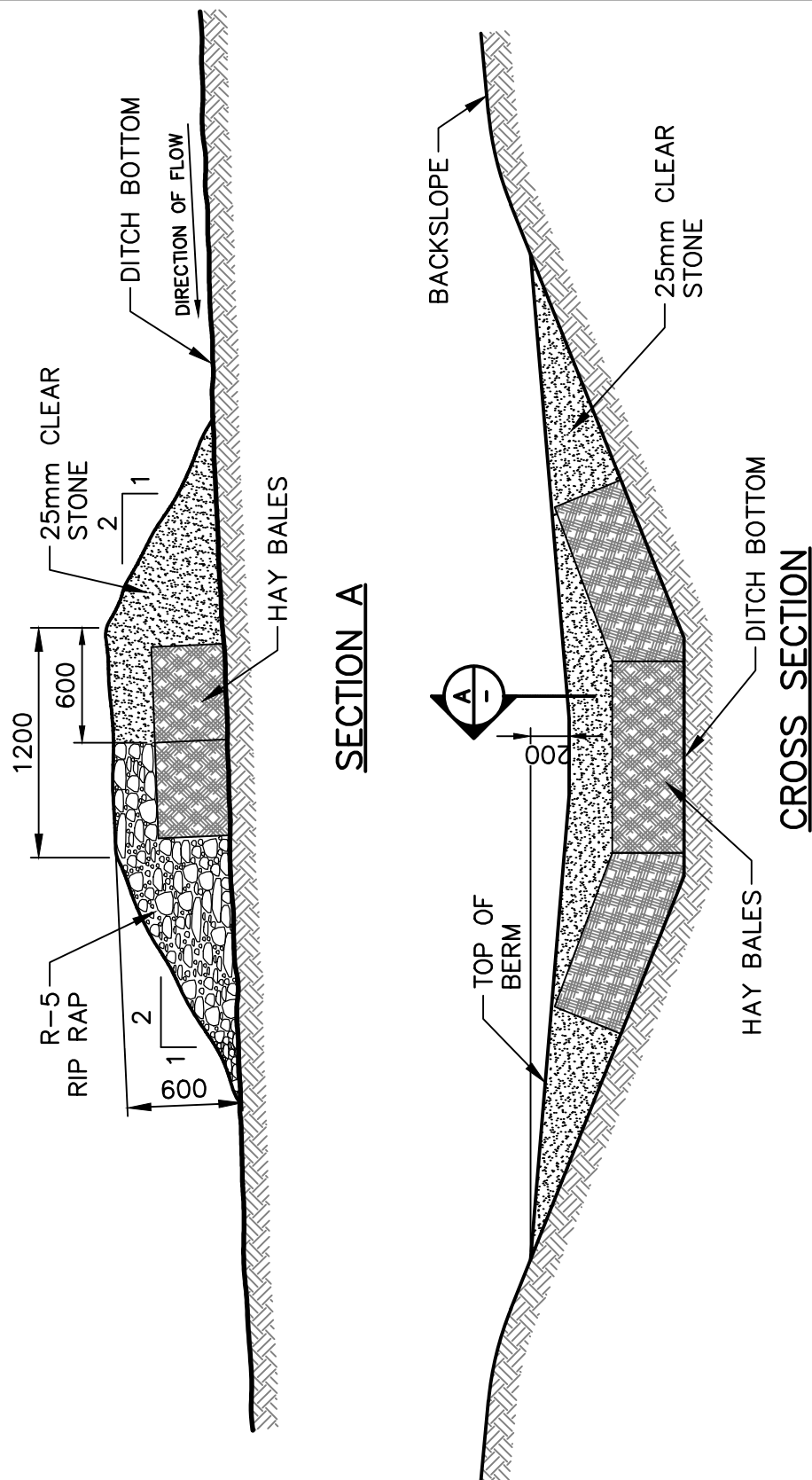

No.	Description	No.	Description	No.	Description
Date	2021-01-21	Scale	1:35	Drawn	THM



TOWN OF QUISPAMISIS

SEDIMENT CONTROL BERM

Drawing

**31.SD02**

DRAWING NAME: Y:\SAINT JOHN\DATA\PROJECTS\2020\2028\19.00 QUISPAMISIS MUNICIPAL SPECIFICATIONS\08 SPEC\CIVIL CAD DETAILS\31.SD03 SEDIMENT SETTLING POND.DWG LAYOUT NAME: SK-6 SEDIMENT SETTLING POND PLOT DATE: December 13, 2022 11:50:07 AM CAD OPERATOR: TRAVISM

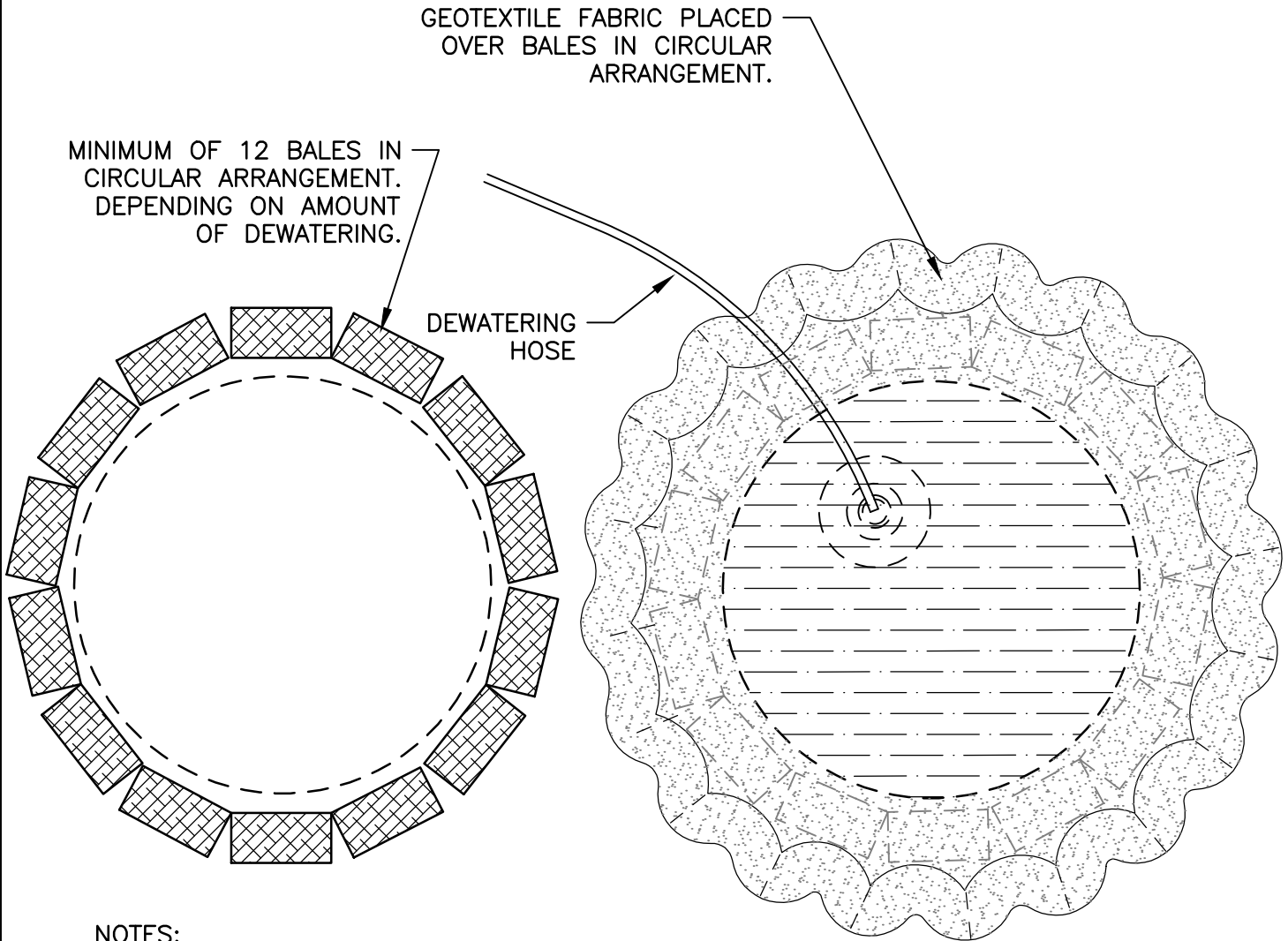

**NOTES:**

1. REPLACE GEOTEXTILE WHEN SEDIMENTS RESTRICT FILTERING ACTION.
2. SEDIMENTS COLLECTED TO BE DISPOSED OF OFF SITE.
3. IF SETTLING POND OVERFLOWS EXCESSIVELY, SIZE OF POND MUST BE INCREASED.

STRAW BALES MAY ALSO BE PLACED ON TOP TO SECURE GEOTEXTILE.

No.	Description	No.	Description
Date	2021-01-21	Scale	N.T.S.
		Drawn	THM
		TOWN OF QUISPAMISIS	
SEDIMENT SETTLING POND		Drawing	
		31.SD03	

DRAWING NAME: Y:\SAINT JOHN\DATA\PROJECTS\2020\202819.00 QUISPAMIS MUNICIPAL SPECIFICATIONS\08 SPEC\CIVIL CAD DETAILS\32.SD01 UTILITY RESTORATION ASPHALT CONCRETE T PATCH.DWG LAYOUT NAME: SK-36 UTILITY RESTORATION ASPHALT CONCRETE T PATCH.PLOT DATE: December 13, 2022 11:51:29 AM CAD OPERATOR:

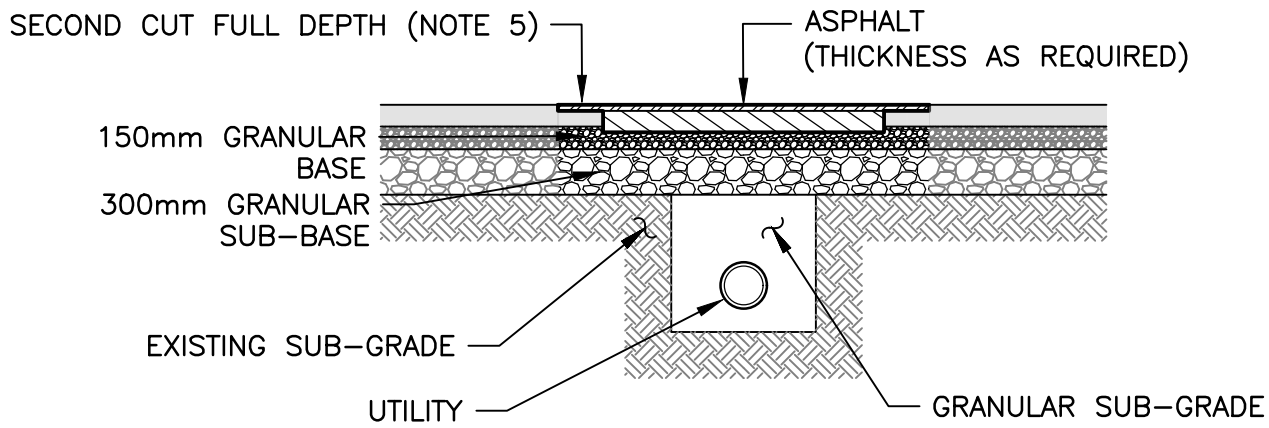
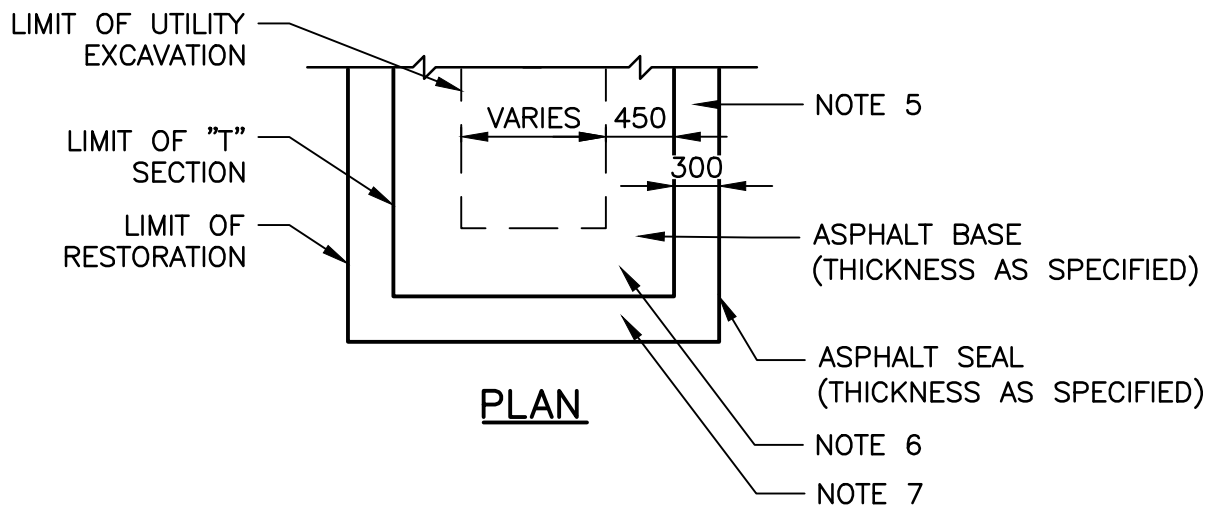

### SECTION

**NOTES:**

1. PIPE BEDDING AND GRANULAR SUB-BASE AS PER TOWN SPECIFICATIONS.
2. EXCAVATE AND REMOVE ANY UNDERMINED ASPHALT.
3. REMOVE ADDITIONAL PAVEMENT TO A PAINTED LANE STRIPE, CURB OR AN EDGE OF PAVEMENT IF SUCH STREET FEATURE IS WITHIN 600mm OF THE SECOND CUT IN THE ASPHALT.
4. THE LIMITS OF RESTORATION SHALL BE RECTANGLE AREA 300mm BEYOND THE OUTER EDGE OF THE WIDEST PORTION OF THE "T" SECTION. THE EXISTING CONCRETE SHALL BE REMOVED TO THE DEPTH EQUAL TO THE THICKNESS OF THE SURFACE COURSE BY COLD MILLING.
5. NEATLY CUT THE PERIMETER OF ALL EXCAVATIONS TO PROVIDE CLEAN STRAIGHT VERTICAL SIDES.
6. CONSTRUCT NEW ASPHALT BASE AS SPECIFIED.
7. CONSTRUCT NEW ASPHALT SEAL AS SPECIFIED.
8. PROVIDE FULL TACK COAT COVERAGE ON ALL VERTICAL AND MILLED SURFACES.
9. ALL WORK SHALL BE DONE IN ACCORDANCE WITH THE TOWN'S SPECIFICATIONS.

No.	Description	No.	Description
Date	2021-01-21	Scale	1:50
		Drawn	THM
		<p>TOWN OF QUISPAMIS</p> <p>UTILITY RESTORATION ASPHALT CONCRETE "T" PATCH</p>	
		Drawing	32.SD01

DRAWING NAME: I:\8 ENG PUBLIC WORKS 2200-2399\ENGINEERING AND PUBLIC WORKS GENERAL 2200\TOO SPECIFICATIONS AND GUIDELINES\DRAWINGS\32.SD02 CONCRETE CURB AND SIDEWALK REV1.DWG LAYOUT NAME: SK-37 CONCRETE CURB AND SIDEWALK PLOT DATE: April 4, 2024 5:05:53 PM CAD OPERATOR: JLEBLANC

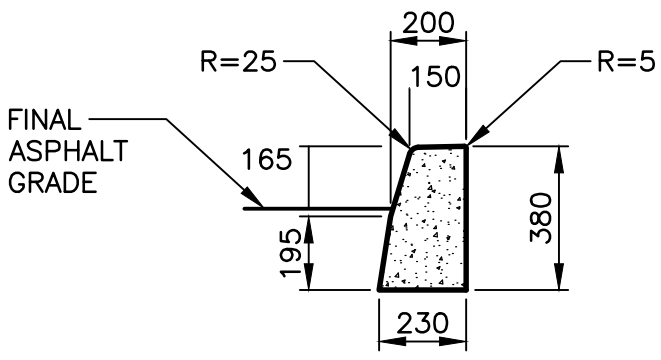

**CONCRETE CURB**

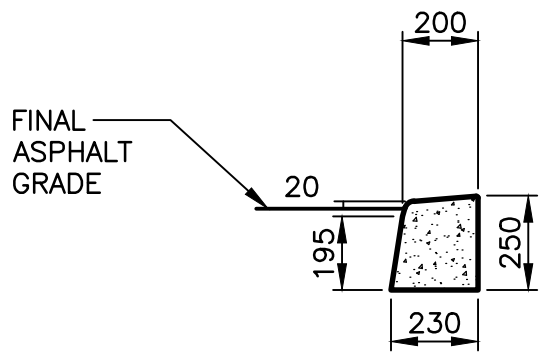

**DEPRESSED CONCRETE CURB**

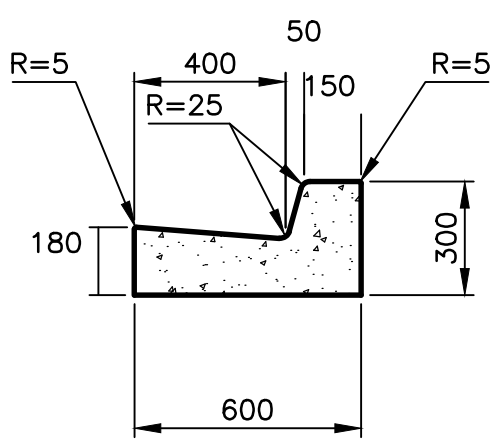

**CONCRETE CURB & GUTTER**

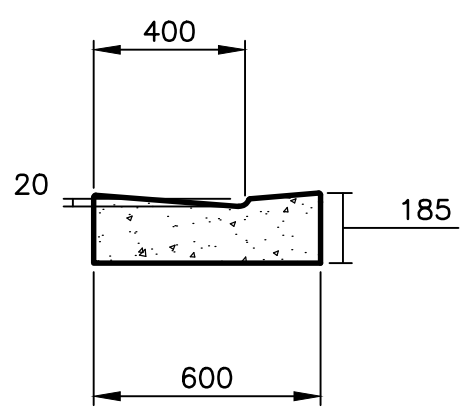

**DEPRESSED CONCRETE CURB & GUTTER**

**NOTES:**

1. ALL DIMENSIONS ARE IN MILLIMETRES UNLESS OTHERWISE NOTED.
2. CONCRETE STRENGTH TO BE 32MPa AT 28 DAYS.
3. DEPRESSED CURB AT DRIVEWAY ENTRANCES TO BE 20mm MAXIMUM ABOVE FINISHED ASPHALT.
4. DEPRESSED CURB AT ACCESS RAMPS TO BE FLUSH WITH FINISHED ASPHALT.
5. CONTROL SAW CUTS AT 3m INTERVALS, BOTTOM OF TRANSITIONS AND AT THE CENTRE OF DRIVEWAY ENTRANCES.

1	Updated April 2024				
No.	Description	No.	Description	No.	Description
Date	2024-02-16	Scale	1:20	Drawn	JFL
		TOWN OF QUISPAMISIS			Drawing
		CONCRETE CURB AND GUTTER			<b>32.SD02</b>

DRAWING NAME: I:\8 ENG PUBLIC WORKS 2200-2399\ENGINEERING AND PUBLIC WORKS GENERAL 2200\TOO SPECIFICATIONS AND GUIDELINES\DRAWINGS\32.SD03 CONCRETE CURB AND GUTTER AND SIDEWALK WITH GRASS BLVD LAYOUT NAME: 3K-38 CONCRETE CURB AND GUTTER AND SIDEWALK PLOT DATE: April 2, 2024 7:15:17 PM CAD OPER

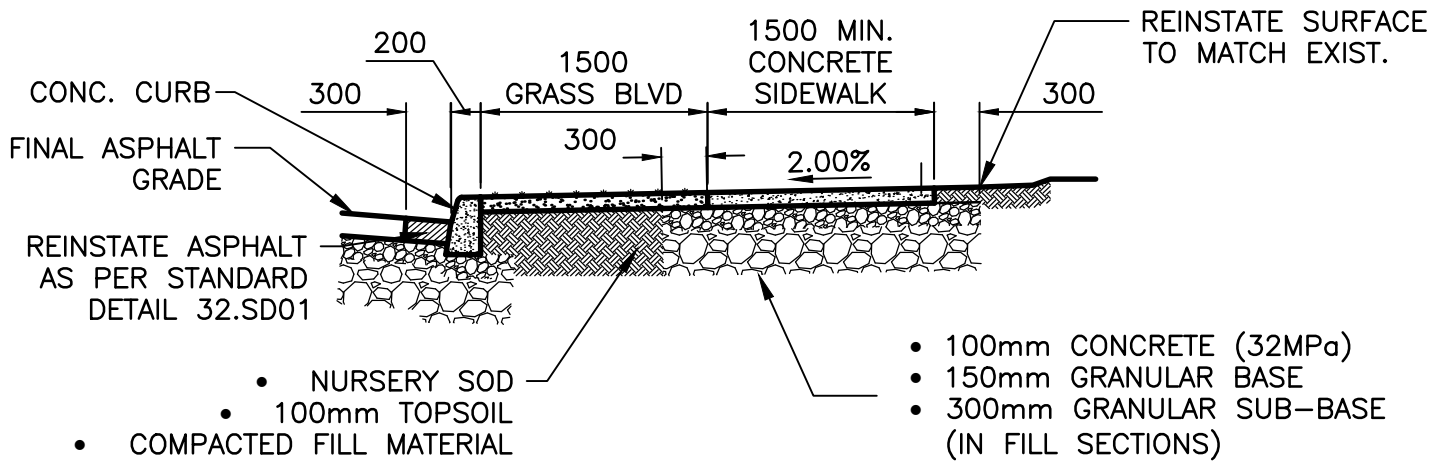

### CONCRETE CURB AND SIDEWALK WITH GRASS BLVD

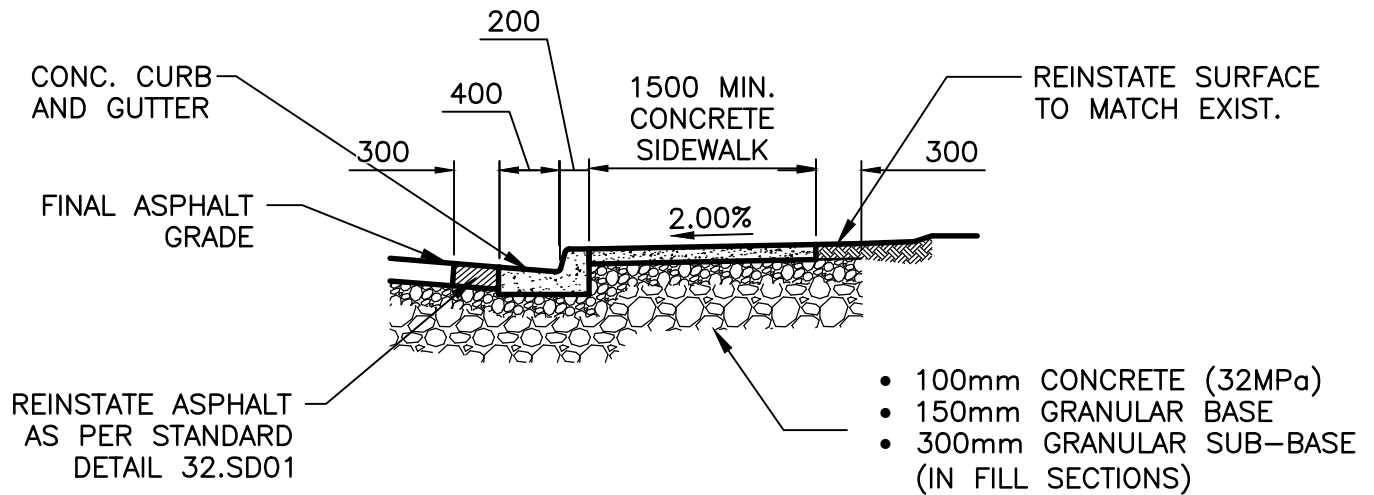

### CONCRETE CURB & GUTTER AND SIDEWALK

#### NOTES:

1. ALL DIMENSIONS ARE IN MILLIMETERS.
2. SIDEWALK TO BE 150mm THICK AT ALL RESIDENTIAL DRIVEWAYS AND 200mm THICK AT ALL COMMERCIAL DRIVEWAYS.
3. INSTALL FIBERBOARD EXPANSION JOINTS AT 6m INTERVALS AND CONTROL SAW CUT JOINTS AT 1.5m INTERVALS.
4. INSTALL ISOLATION JOINT FILLER AROUND MANHOLES, AT BUILDINGS, FIRE HYDRANTS, ETC.
5. INSTALL WELDED WIRE MESH AT COMMERCIAL DRIVEWAYS OR AS DIRECTED BY ENGINEER.

01	Updated April 2024				
No.	Description	No.	Description	No.	Description
Date	2024-02-16	Scale	1:50	Drawn	JFL
			TOWN OF QUISPAMISIS		Drawing
			CONCRETE CURB AND GUTTER AND SIDEWALK		<b>32.SD03</b>

DRAWING NAME: I:\8 ENG PUBLIC WORKS 2200-2399\ENGINEERING AND PUBLIC WORKS GENERAL 2200\TOO SPECIFICATIONS AND GUIDELINES\DRAWINGS\32.SD03A DRIVEWAY ENTRANCE CONCRETE CURB AND GUTTER AND SIDEWALK REV1.DWG LAYOUT NAME: 3K-38 CONCRETE CURB AND GUTTER AND SIDEWALK PLOT DATE: March 4, 2024

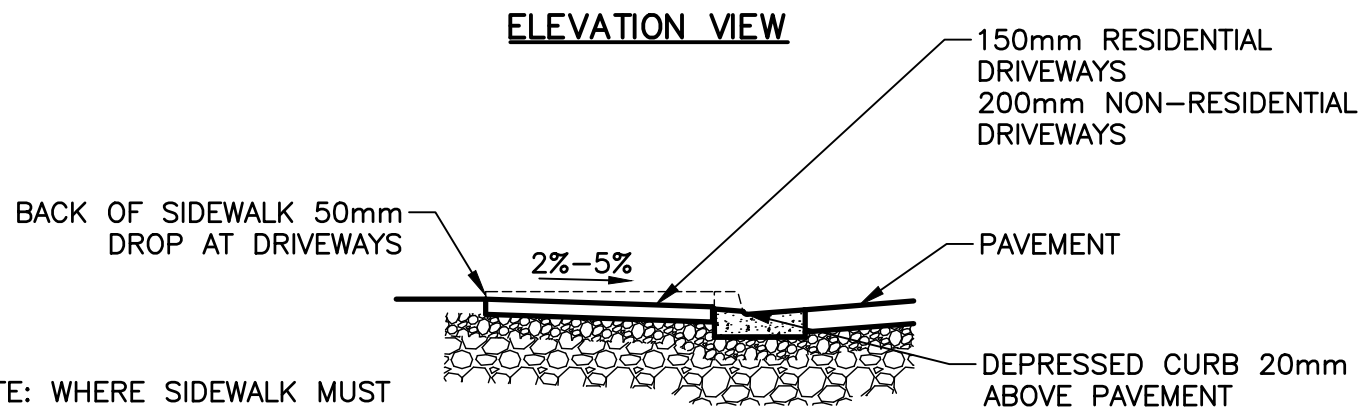
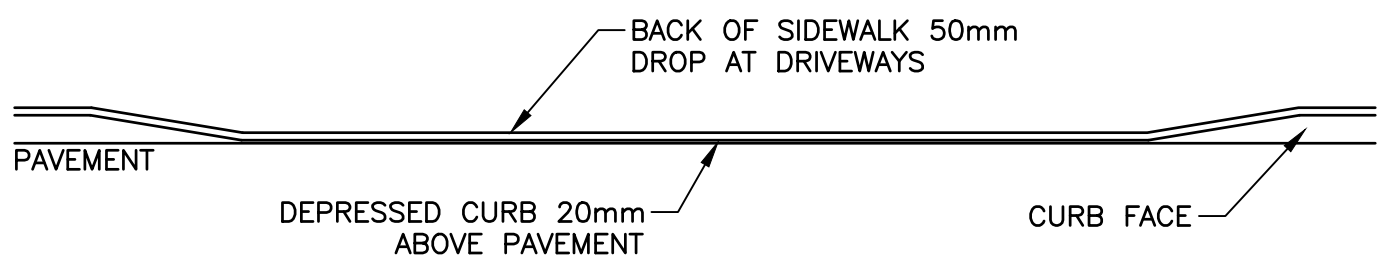
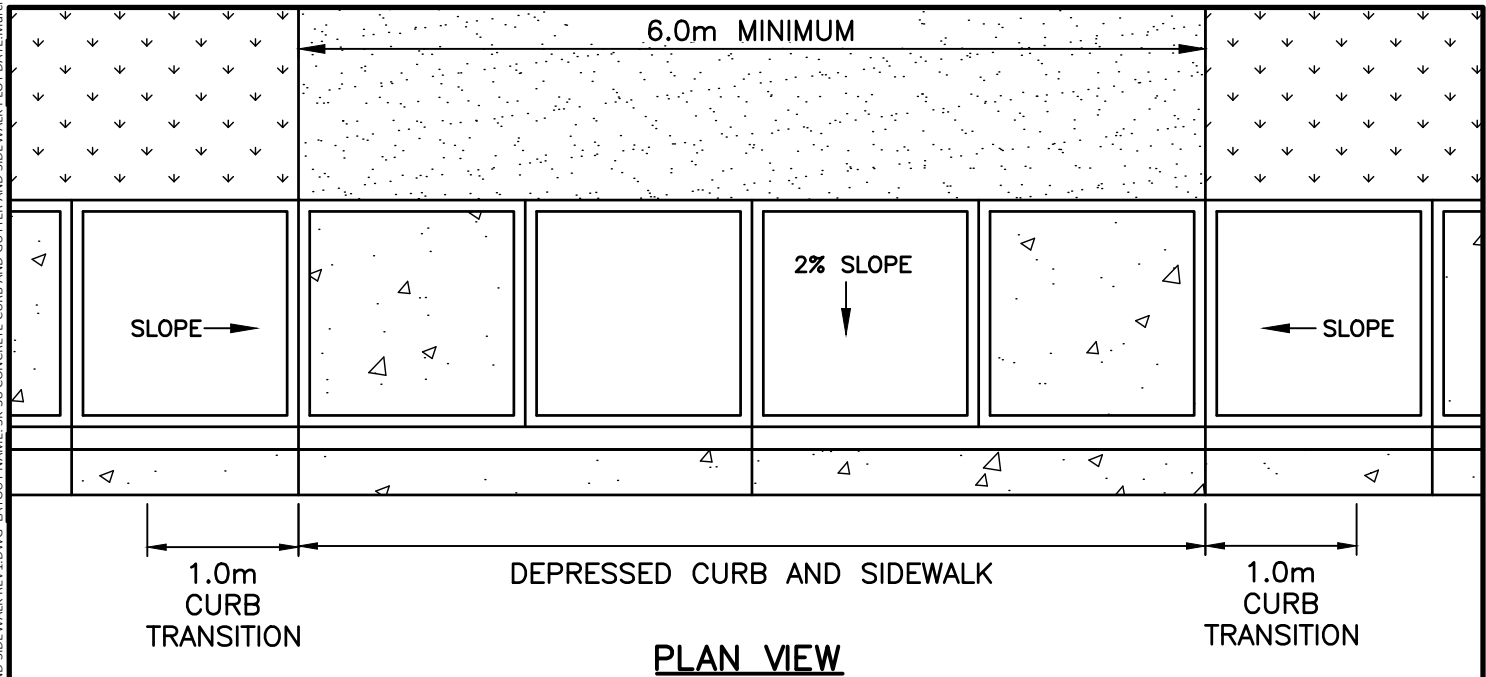

**NOTE: WHERE SIDEWALK MUST MATCH EXISTING DRIVEWAY GRADE, A FULL (FRONT TO BACK) DEPRESSED SECTION MAY BE REQUIRED.**

01	Added April 2024		
No.	Description	No.	Description
Date	2024-04-01	Scale	1:50
		Drawn	JFL



**TOWN OF QUISPAMISIS**

**DRIVEWAY ENTRANCE WITH CONCRETE CURB AND GUTTER AND SIDEWALK**

Drawing

**32.SD03A**

DRAWING NAME: 1:18 ENG PUBLIC WORKS 2:200-2:399 ENGINEERING AND PUBLIC WORKS GENERAL 2:200 TOG SPECIFICATIONS AND GUIDELINES DRAWINGS 3:2:SD04 SIDEWALK AND TYPICAL WHEELCHAIR RAMPS REV1.DWG LAYOUT NAME: SK-38 CONCRETE CURB AND GUTTER AND SIDEWALK PLOT DATE: March 4, 2024 9:36:46 AM CAD OPER

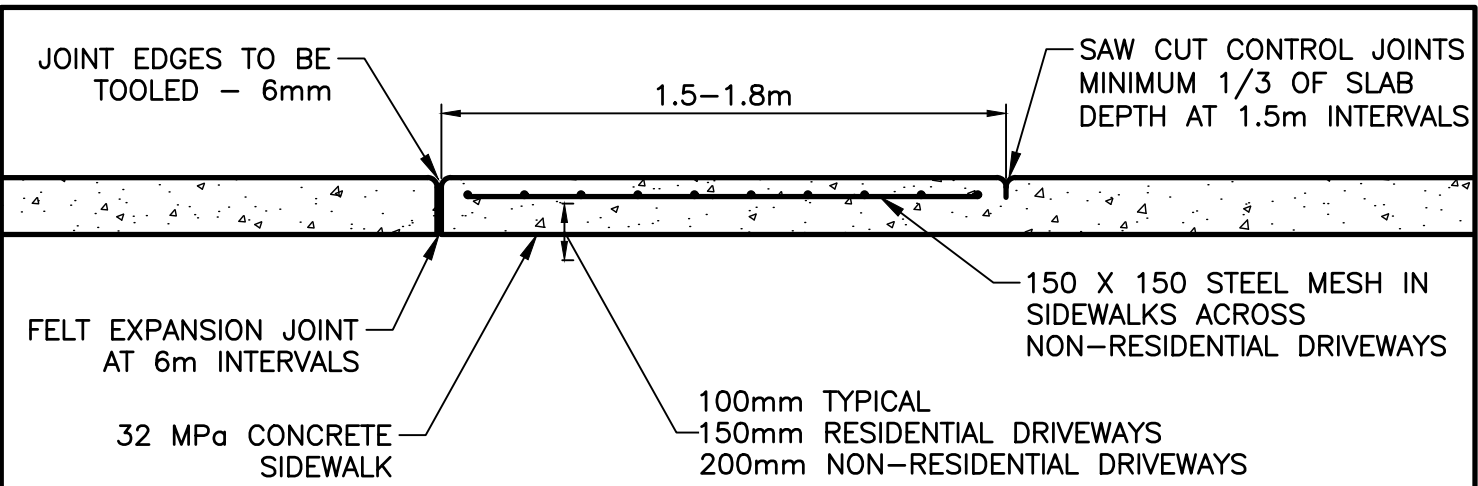

**ELEVATION VIEW**

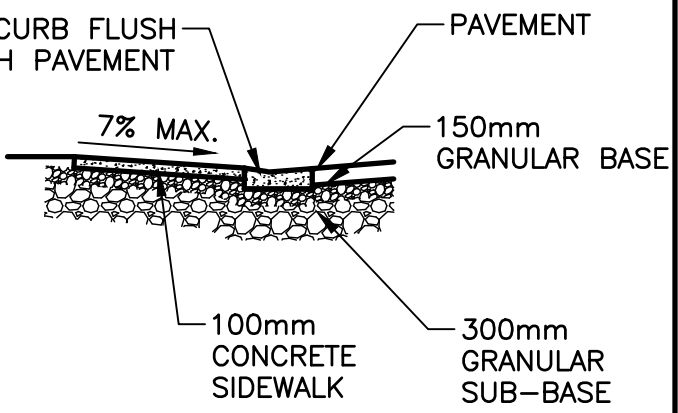

**CROSS-SECTION VIEW**

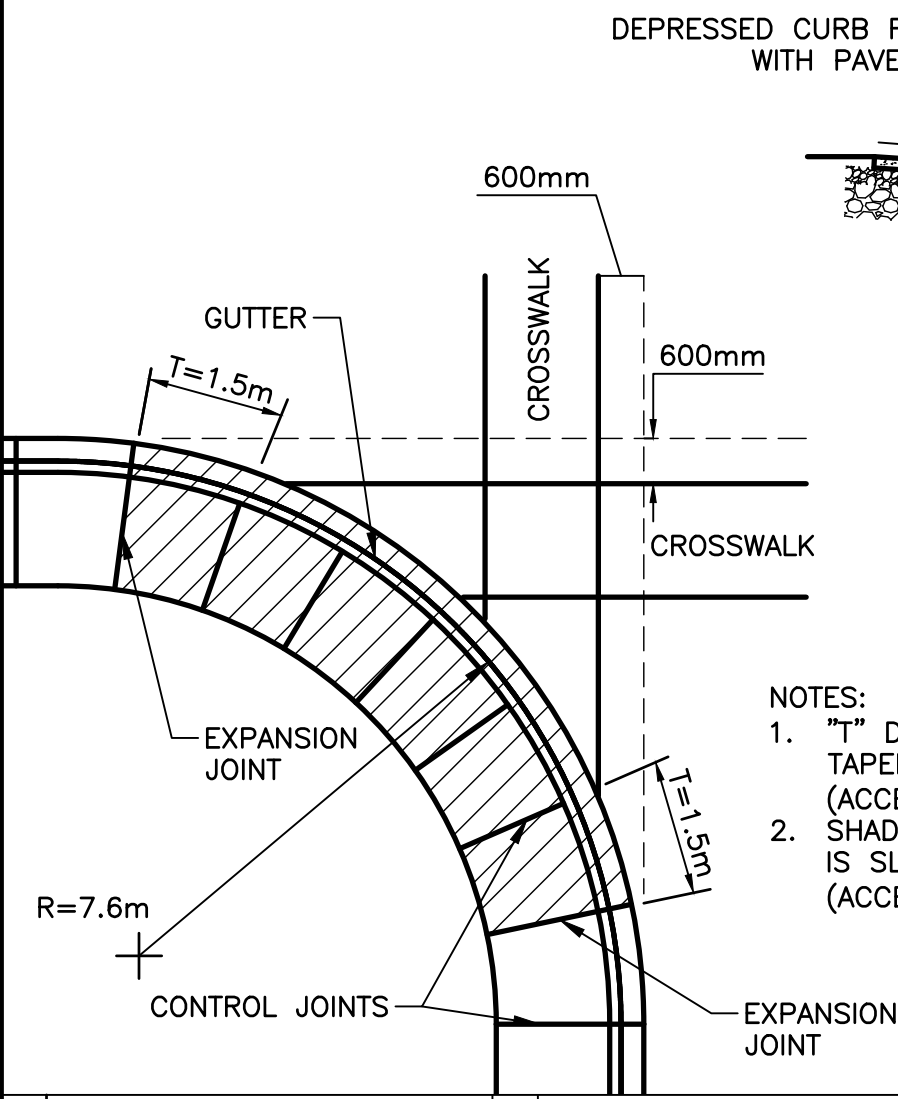

**PLAN VIEW**

- NOTES:
1. "T" DENOTES AREA WHERE CURB IS TAPERED DOWN TO DEPRESSED CURB (ACCESS RAMP) SECTION.
  2. SHADING DENOTES AREA WHERE SIDEWALK IS SLOPED DOWN TO DEPRESSED CURB (ACCESS RAMP) SECTION.

01	Updated April 2024				
No.	Description	No.	Description	No.	Description
Date	2024-04-01	Scale	N.T.S.	Drawn	JFL

	TOWN OF QUISPAMISIS	Drawing
	SIDEWALK ACCESS RAMPS	

DRAWING NAME: Y:\SAINT JOHN\DATA\PROJECTS\2020\202819.00 QUISPAMIS MUNICIPAL SPECIFICATIONS\08 SPEC\CVIL CAD DETAILS\32.SD05 CHAIN LINK FENCE.DWG LAYOUT NAME: SK-42 CHAIN LINK FENCE PLOT DATE: December 13, 2022 11:54:49 AM CAD OPERATOR: TRAVIS M

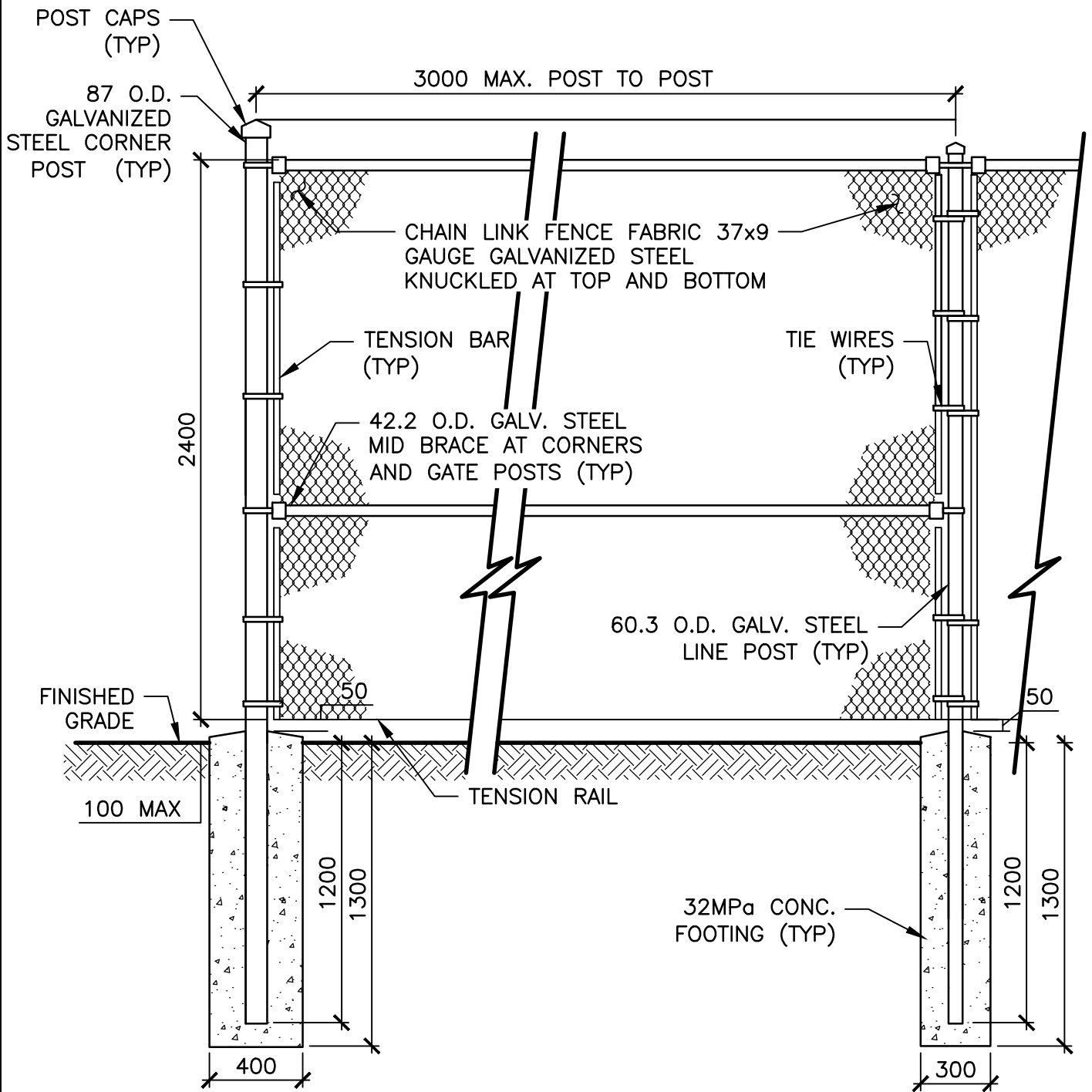

No.	Description	No.	Description	No.	Description
Date	2021-01-21	Scale	1:25	Drawn	THM
			TOWN OF QUISPAMIS		Drawing
			CHAIN LINK FENCE		<b>32.SD05</b>

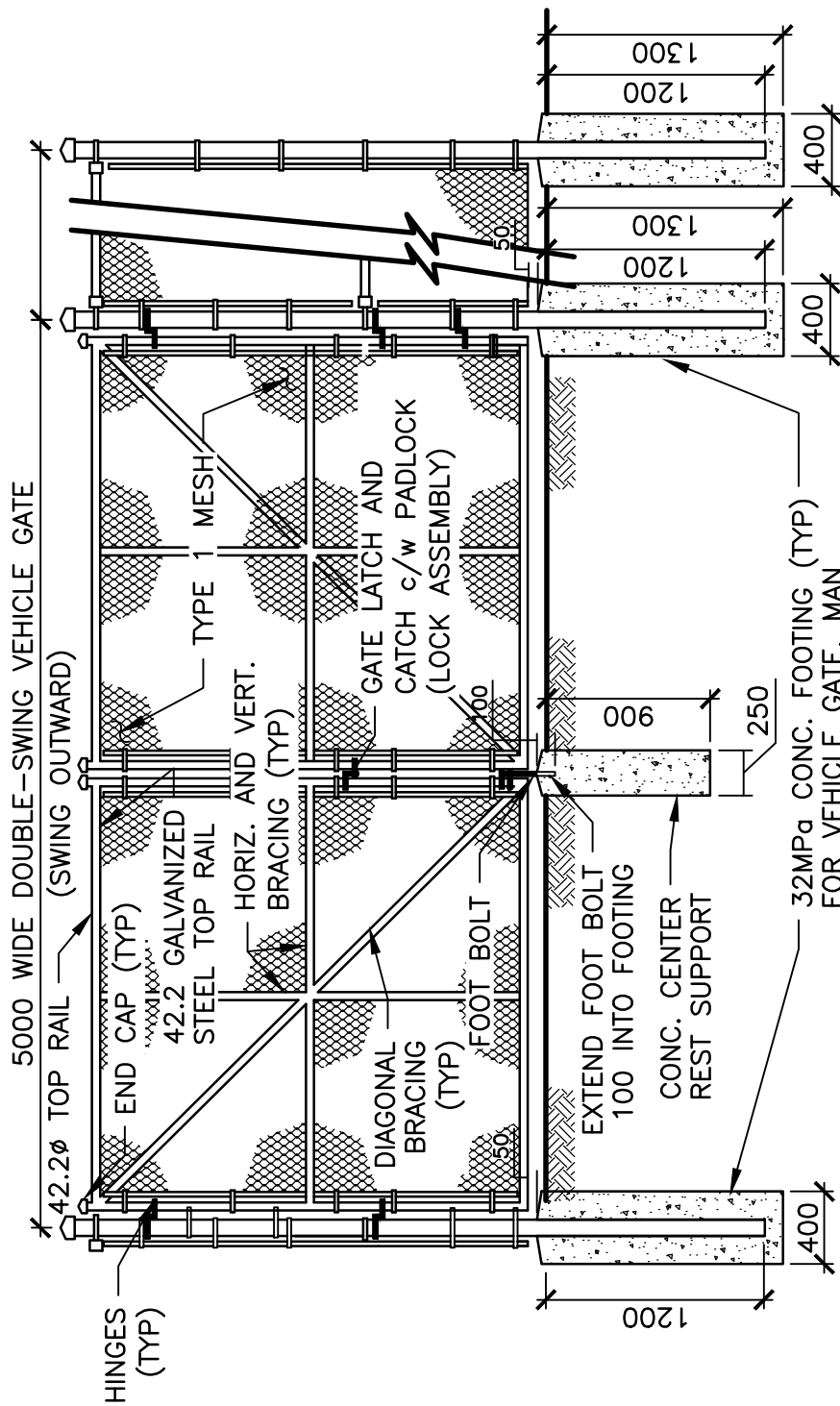

- NOTES:**
1. INSTALL CORNER POSTS WHERE CHANGES IN ALIGNMENT EXCEED 10".
  2. INSTALL BRACE BETWEEN END AND GATE POSTS AND NEAREST LINE POST. INSTALL BRACES ON BOTH SIDES OF CORNER AND STRAINING POSTS.
  3. INSTALL OVERHANG TOPS AND CAPS.
  4. PLACE TENSION BAR BANDS @ 3000 INTERVALS.
  5. SECURE FABRIC TO TOP RAILS, LINE POSTS AND BOTTOM TENSION RAIL WITH TIE WIRES AT 450mm INTERVALS.
  6. ALL FENCE FABRIC, STEEL FRAMEWORK, GATES AND INSTALLATION TO CONFORM WITH CAN/CSB-138.1 THROUGH 138.4.
  7. POSTS TO BE SCHEDULE 40, HOT DIPPED GALVANIZED STEEL COATED WITH A 3mil
  8. GATES TO BE DOUBLE SWING, FRAMED WITH 42 O.D. FRAMING, 2.0mm WALL THICKNESS.
  9. PROVIDE CLEARANCES BETWEEN BOTTOM OF FENCE AND GROUND SURFACE OF 150mm.

No.	Description	No.	Description	No.	Description
Date	2021-01-21	Scale	1:40	Drawn	THM
			TOWN OF QUISPAMIS  CHAIN LINK SECURITY GATE WITH VEHICLE GATE		Drawing  <b>32.SD06</b>

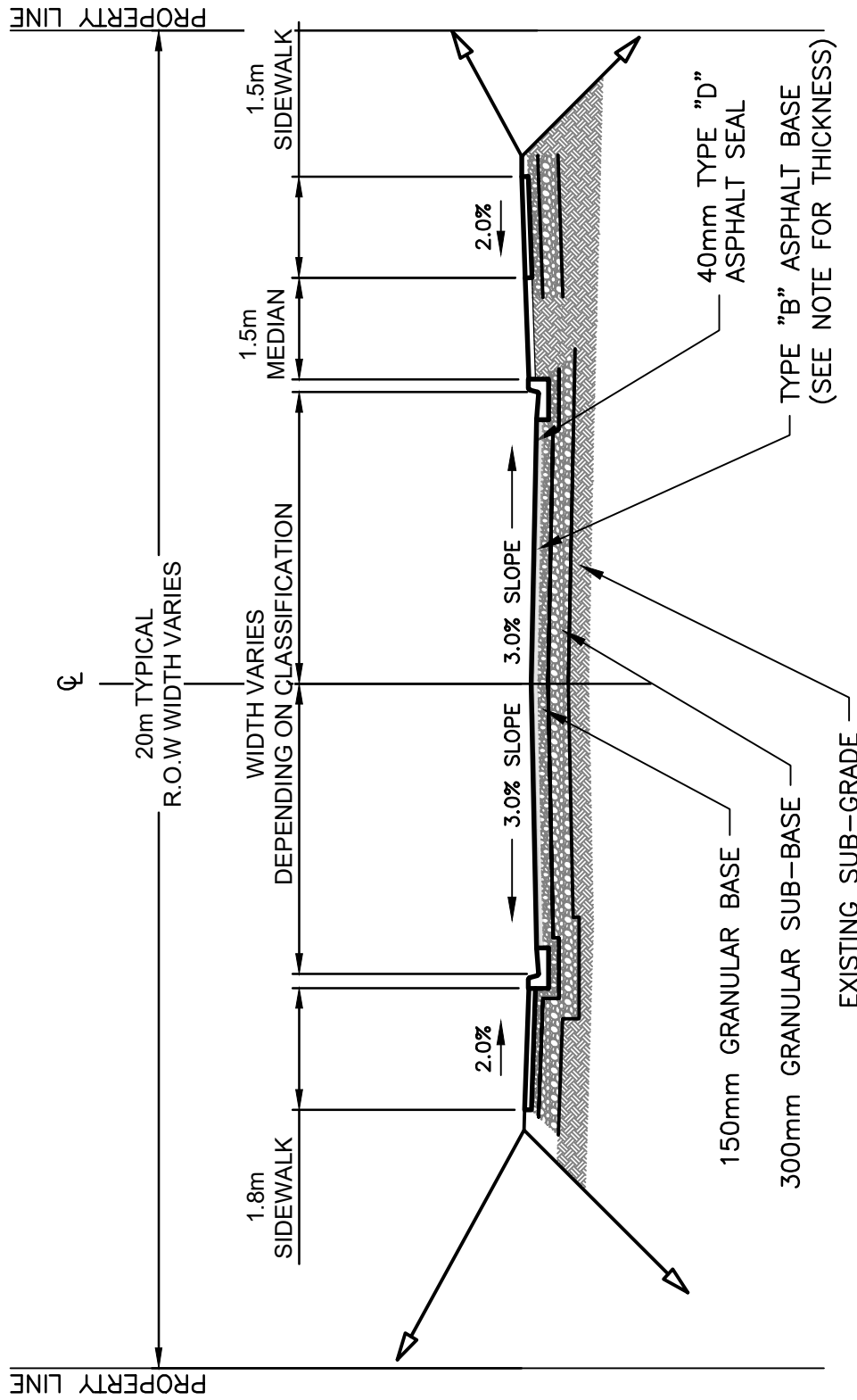

**NOTES:**

- ASPHALT BASE THICKNESS:  
LOCAL = 50mm  
MINOR COLLECTOR = 75mm  
COLLECTOR = 100mm
- GRANULAR BASE THICKNESS:  
LOCAL = 300mm  
MINOR COLLECTOR = 300mm  
COLLECTOR = 450mm

01	Added April 2024				
No.	Description	No.	Description	No.	Description
Date	2024-04-01	Scale	1:100	Drawn	JFL



TOWN OF QUISPAMISIS  
TYPICAL URBAN ROAD  
CROSS SECTION

Drawing  
**32.SD07**

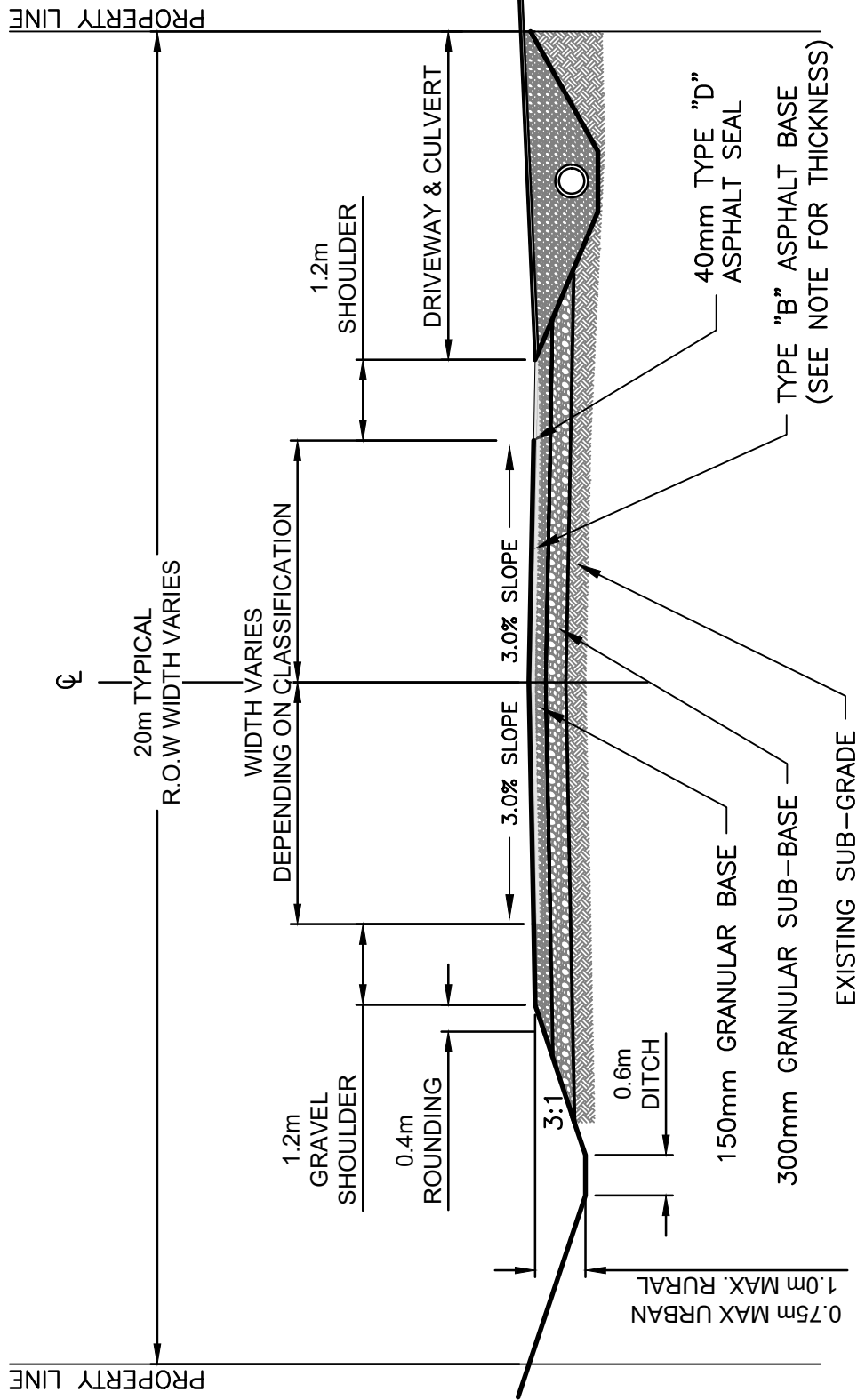

**NOTES:**

- ASPHALT BASE THICKNESS:  
LOCAL = 50mm  
MINOR COLLECTOR = 75mm  
COLLECTOR = 100mm
- GRANULAR BASE THICKNESS:  
LOCAL = 300mm  
MINOR COLLECTOR = 300mm  
COLLECTOR = 450mm

01	Added April 2024				
No.	Description	No.	Description	No.	Description
Date	2024-04-01	Scale	1:100	Drawn	JFL



TOWN OF QUISPAMISIS

TYPICAL RURAL ROAD  
CROSS SECTION

Drawing

**32.SD08**

DRAWING NAME: I:\8 ENG PUBLIC WORKS GENERAL 2200\TOO SPECIFICATIONS AND GUIDELINES\DRAWINGS\32.SD09 CUL DE SAC.DWG LAYOUT NAME: SK-37 CONCRETE CURB AND SIDEWALK PLOT DATE: April 14, 2024 5:04:22 PM CAD OPERATOR: JLEBLANC

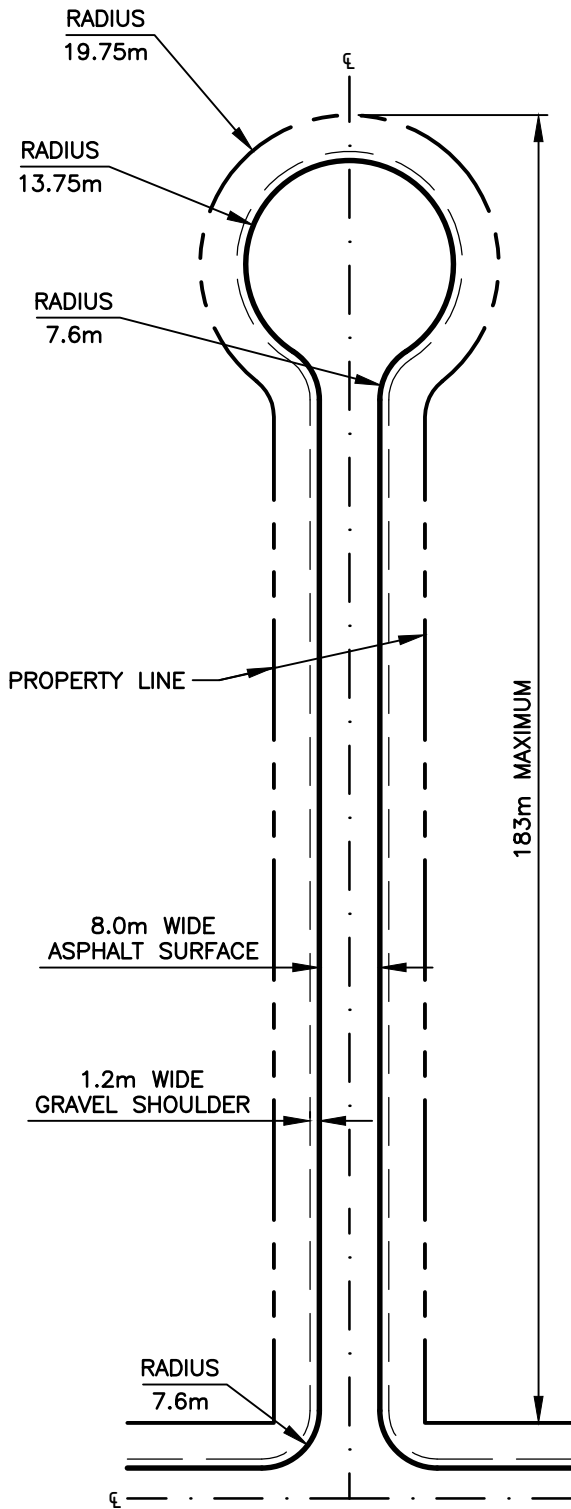

**TYPICAL LAYOUT**

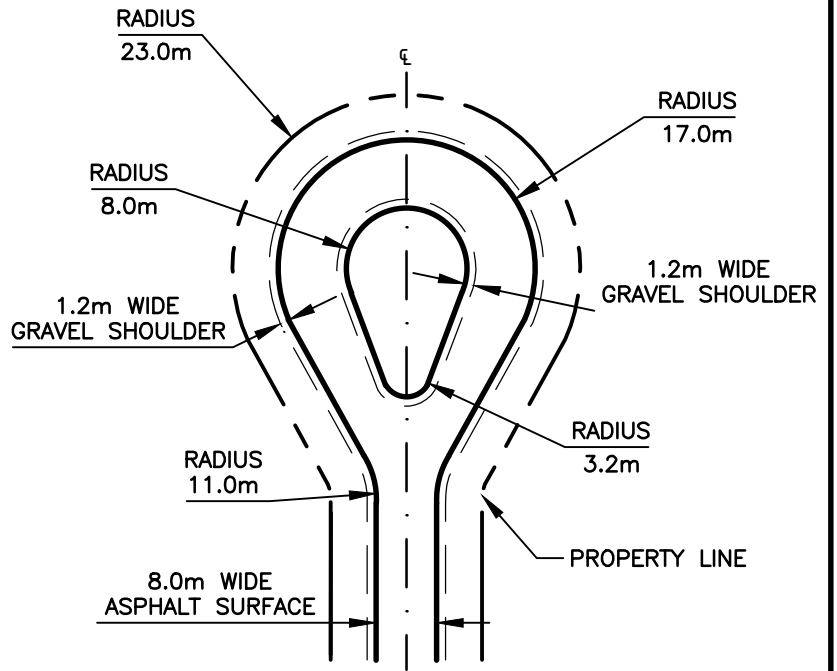

**CUL-DE-SAC WITH ISLAND**

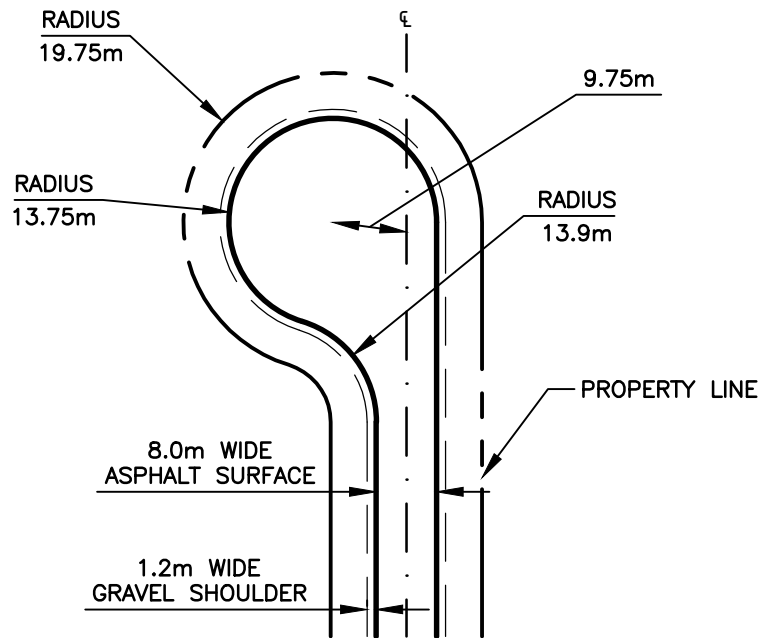

**OPTIONAL LAYOUT**

01	Added April 2024				
No.	Description	No.	Description	No.	Description
Date	2024-04-01	Scale	1:1000	Drawn	JFL



TOWN OF QUISPAMISIS

CUL-DE-SAC

Drawing

**32.SD09**

DRAWING NAME: I:\8 ENG PUBLIC WORKS 2200-2399\ENGINEERING AND PUBLIC WORKS GENERAL 2200\TOO SPECIFICATIONS AND GUIDELINES\DRAWINGS\32.SD10 ANGLE INTERSECTION.DWG LAYOUT NAME: SK-40 GUIDE RAIL PLOT DATE: April 4, 2024 4:27:38 PM CAD OPERATOR: JLEBLANC

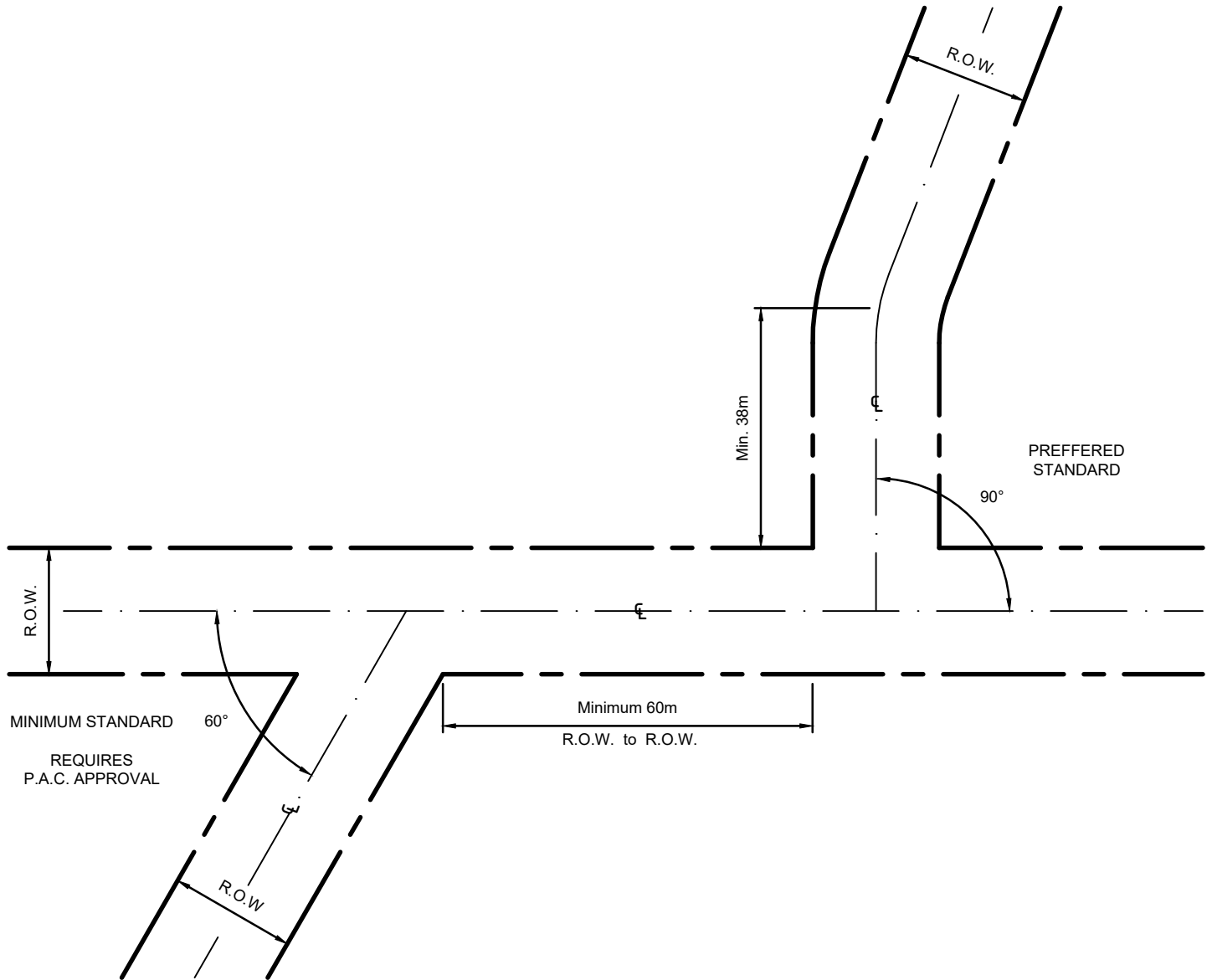

**NOTES :**

- 1) INTERSECTIONS OF MORE THAN 2 STREETS ARE PROHIBITED.
- 2) STREET INTERSECTIONS ON THE SAME OR OPPOSITE SIDE OF A STREET ARE TO BE NO CLOSER THAN 60m. UNLESS WARRANTED BY EXCEPTIONAL SITE CONDITIONS.

No.	Description	No.	Description	No.	Description
Date	2024-04-01	Scale	1:1000	Drawn	JFL
			TOWN OF QUISPAMISIS		Drawing
			ANGLE INTERSECTION		<b>32.SD10</b>

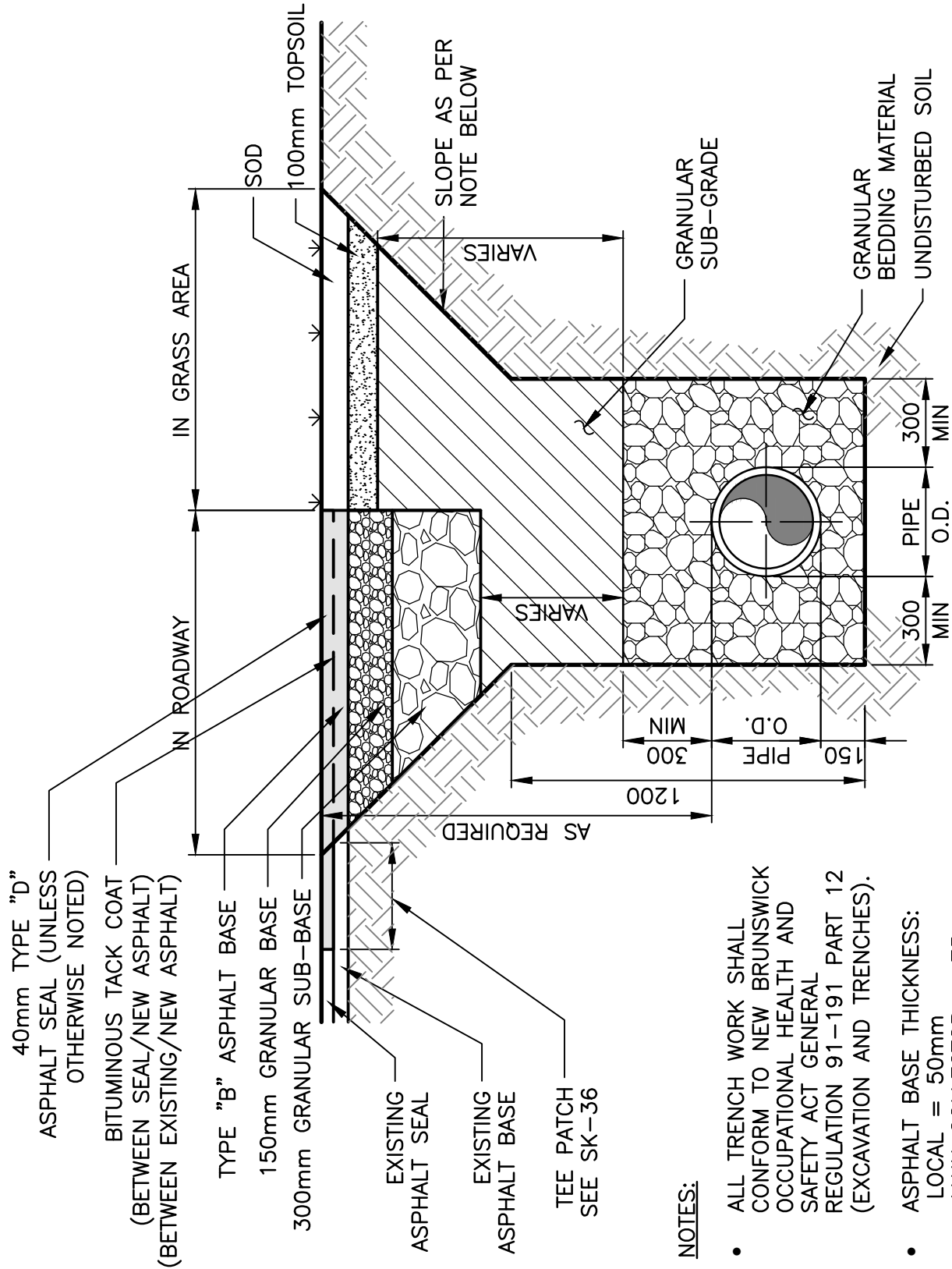

**NOTES:**

- ALL TRENCH WORK SHALL CONFORM TO NEW BRUNSWICK OCCUPATIONAL HEALTH AND SAFETY ACT GENERAL REGULATION 91-191 PART 12 (EXCAVATION AND TRENCHES).
- ASPHALT BASE THICKNESS:  
LOCAL = 50mm  
MAIN COLLECTOR = 75mm  
COLLECTOR = 100mm

No.	Description	No.	Description	No.	Description
Date	2021-01-21	Scale	1:20	Drawn	THM
			TOWN OF QUISPAMIS SINGLE PIPE TRENCH		Drawing <b>33.SD01</b>

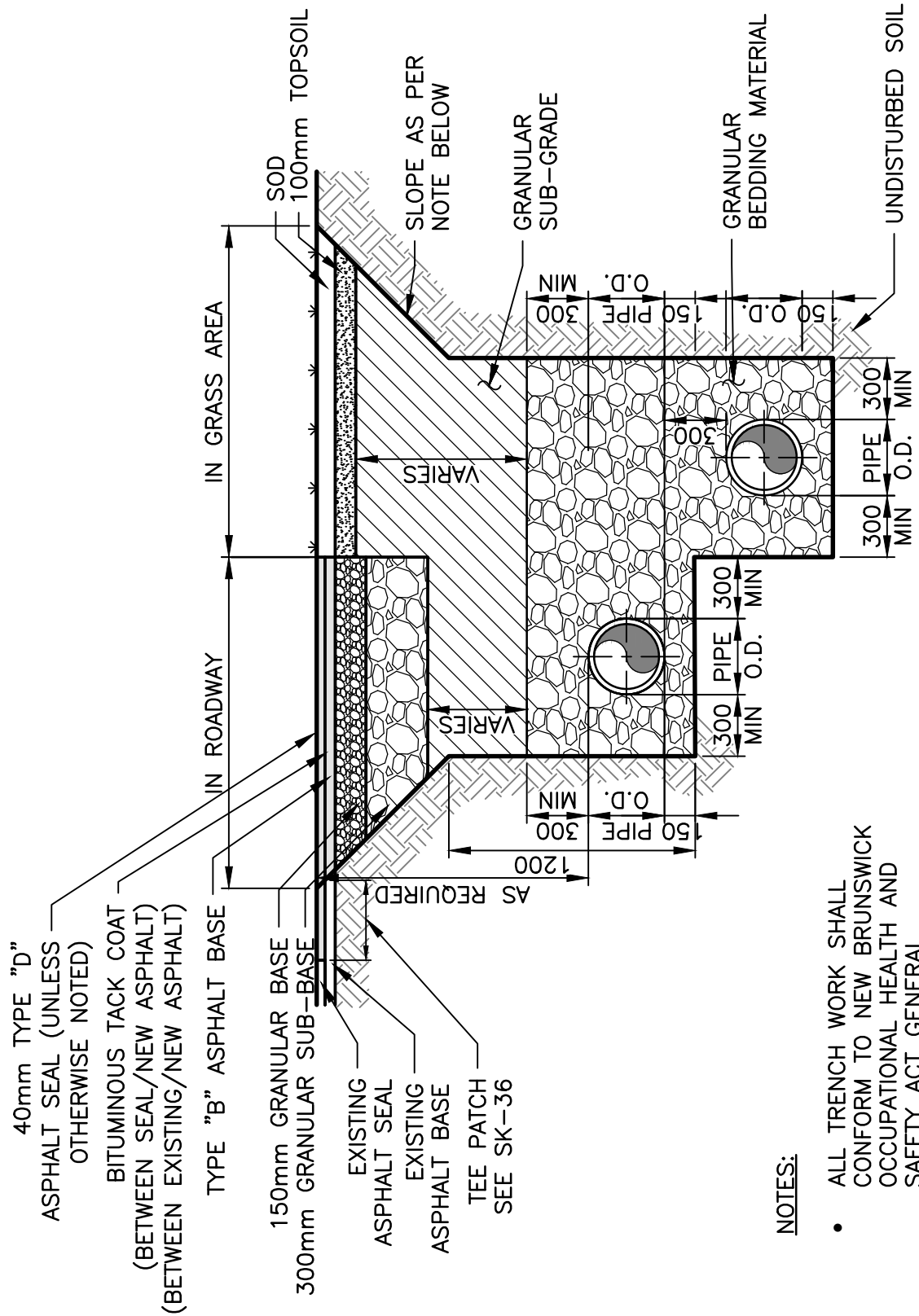

**NOTES:**

- ALL TRENCH WORK SHALL CONFORM TO NEW BRUNSWICK OCCUPATIONAL HEALTH AND SAFETY ACT GENERAL REGULATION 91-191 PART 12 (EXCAVATION AND TRENCHES).
- ASPHALT BASE THICKNESS:  
 LOCAL = 50mm  
 MAIN COLLECTOR = 75mm  
 COLLECTOR = 100mm

No.	Description	No.	Description	No.	Description
Date	2021-01-21	Scale	1:30	Drawn	THM
			TOWN OF QUISPAMIS TWO PIPE TRENCH		Drawing <b>33.SD02</b>

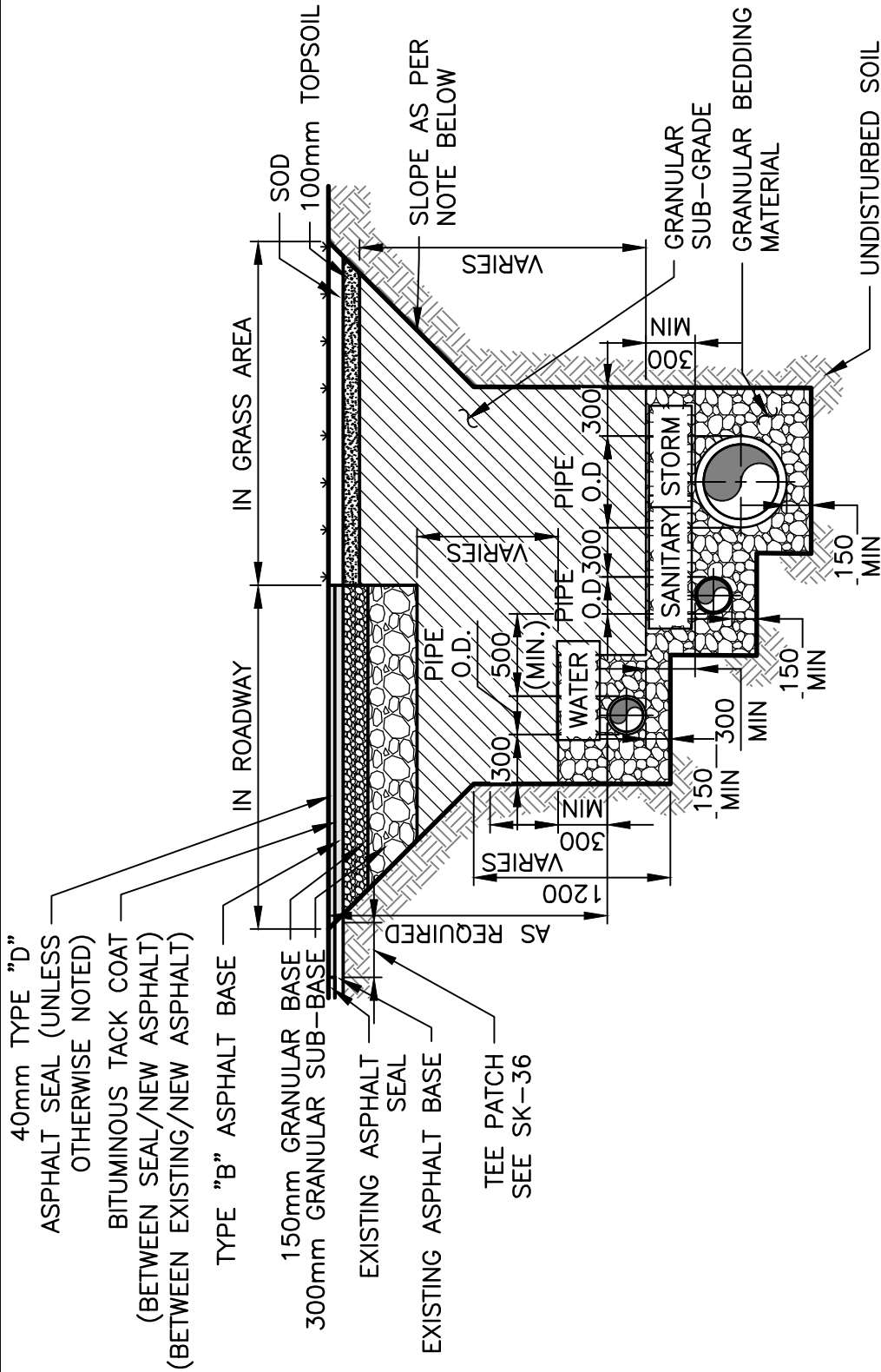

**NOTES:**

1. ALL TRENCH WORK SHALL CONFORM TO NEW BRUNSWICK OCCUPATIONAL HEALTH AND SAFETY ACT GENERAL REGULATION 91-191 PART 12 (EXCAVATION AND TRENCHES).
2. ASPHALT BASE THICKNESS:  
 LOCAL = 50mm  
 MAIN COLLECTOR = 75mm  
 COLLECTOR = 100mm
3. IF CROWNS OF STORMWATER AND WASTEWATER SEWERS ARE NOT MATCHED.

No.	Description	No.	Description	No.	Description
Date	2021-01-21	Scale	1:40	Drawn	THM
			TOWN OF QUISPAMIS  THREE PIPE TRENCH		Drawing  <b>33.SD03</b>

DRAWING NAME: \1\8 ENG PUBLIC WORKS 2240-2399\ENGINEERING AND PUBLIC WORKS GENERAL \200\CAD PROJECTS\2025\2-025-013-STANDARD DRAWINGS (IB)\DESIGN\33.SD03-ROCK TRENCH PAYMENT LIMITS.DWG LAYOUT NAME: TRENCH LAYOUT PAYMENT LIMITS (ROCK EXCAVATION) | PLOT DATE: March 11, 2025 1:35:57 PM - CAD OPEN

FINAL GRADE

FINAL GRADE

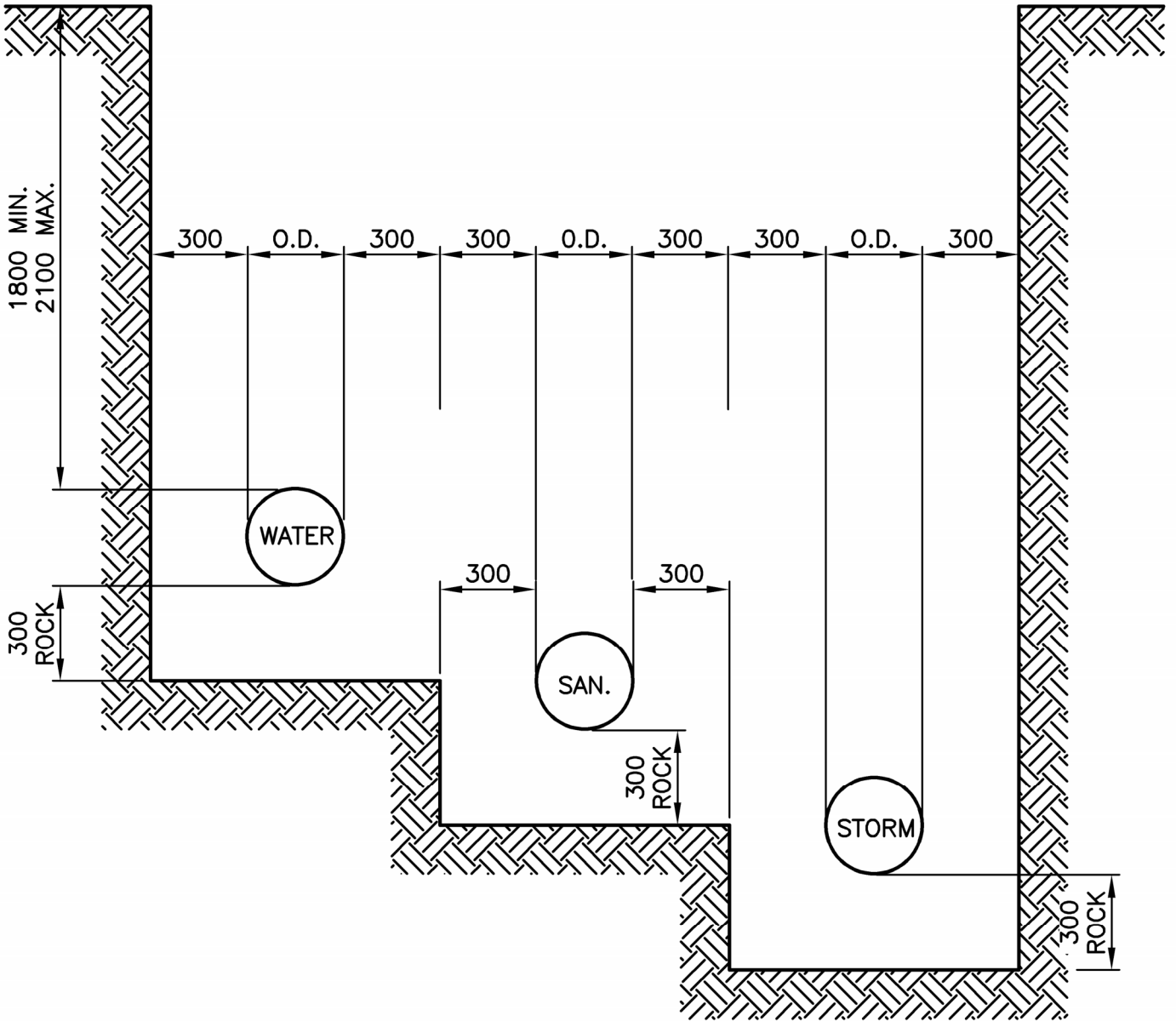

**NOTES:**

1. ALL DIMENSIONS ARE IN MILLIMETERS.
2. VERTICAL AND HORIZONTAL CLEARANCES TO CONFORM WITH ATLANTIC CANADA GUIDELINES MANUAL FOR WASTEWATER AND WATER.
3. TRENCH SIDES TO BE SHORED OR SLOPED IN ACCORDANCE WITH NB OCCUPATIONAL HEALTH AND SAFETY ACT.

No.	Description	No.	Description	No.	Description
Date	2025-01-21	Scale	N.T.S.	Drawn	IB
			TOWN OF QUISPAMISIS		Drawing
			ROCK TRENCH PAYMENT LIMITS		<b>33.SD03A</b>

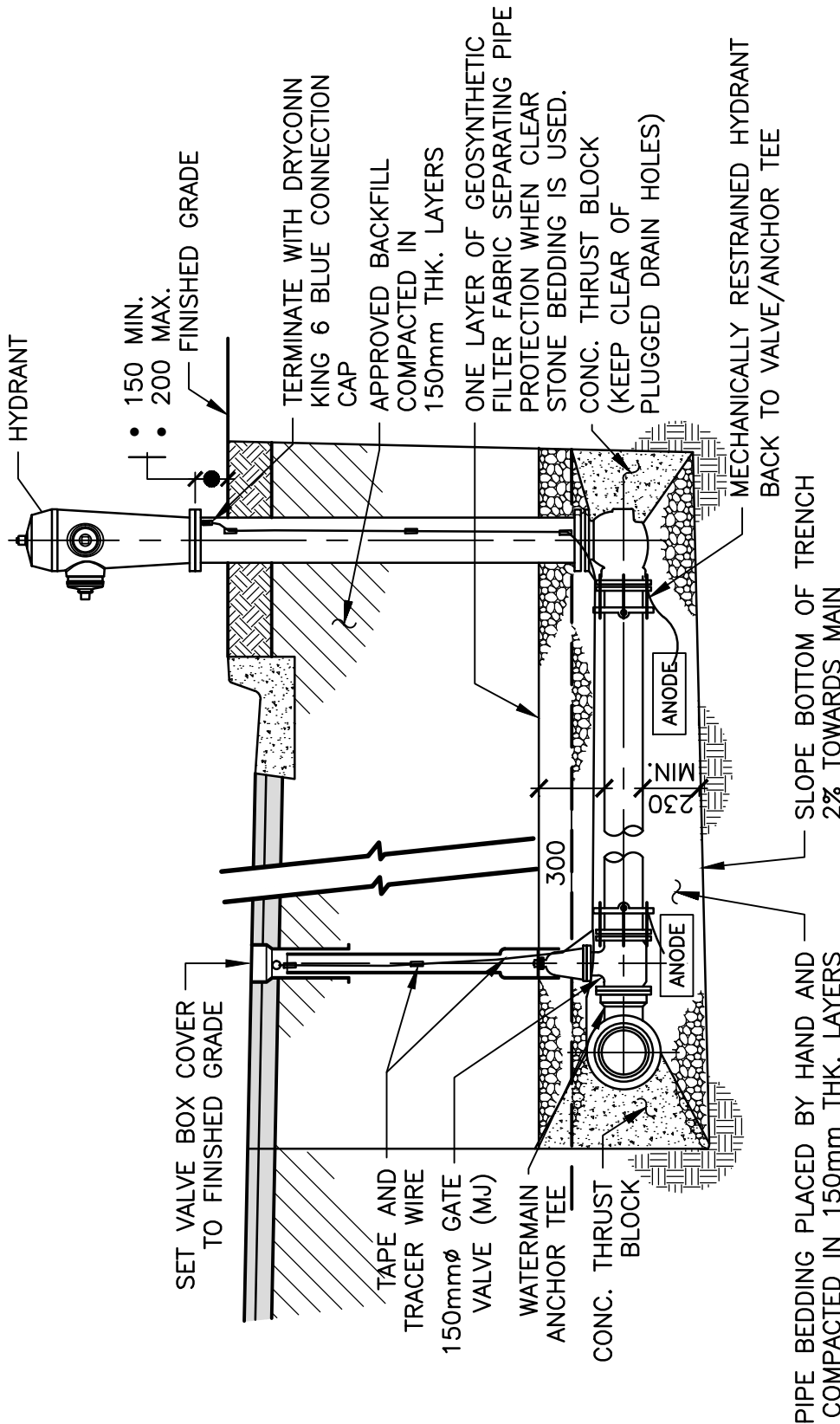

**NOTES:**

1. ANODES TO BE ZINC 24-48 TYPE INSTALLED BY USE OF DOUBLE NUT.
2. USE ONLY APPROVED PRODUCTS FOR MECHANICAL RESTRAINT.

No.	Description	No.	Description	No.	Description
Date	2021-01-21	Scale	1:30	Drawn	THM
			TOWN OF QUISPAMIS		Drawing
			FIRE HYDRANT		
					<b>33.SD04</b>

DRAWING NAME: 1:18 ENG PUBLIC WORKS 2:200-2:999 ENGINEERING AND PUBLIC WORKS GENERAL 2:200 CAD PROJECTS DETAIL DRAWINGS AUTO CAD DETAIL DRAWINGS 3:33 SD05 ADJUSTABLE VALVE BOX (2026).DWG LAYOUT NAME: SK-8 SLIDE VALVE BOX PLOT DATE: February 12, 2026 9:20:13 AM CAD OPERATOR: JLEBLANC

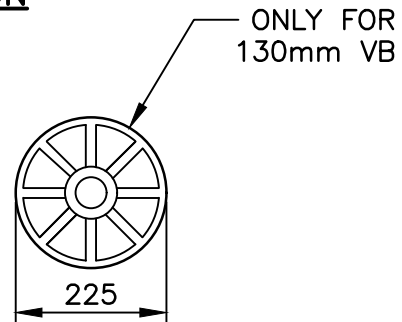
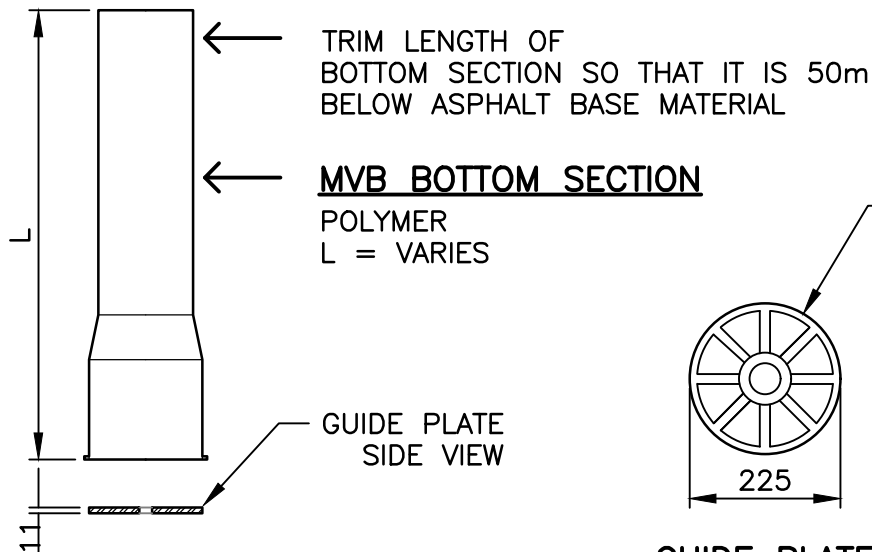
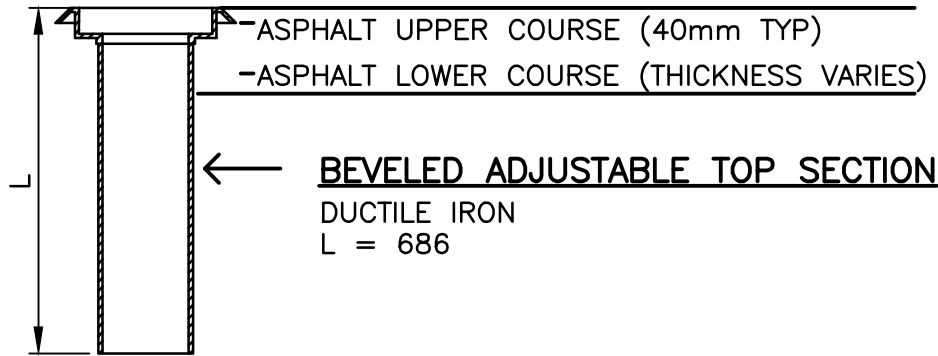
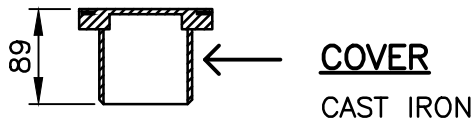

**GUIDE PLATE**  
DUCTILE IRON

**NOTES:**

1. ALL DIMENSIONS ARE IN MILLIMETERS.
2. MATERIAL IS GREY CAST IRON TO ASTM 126, CLASS 30, UNLESS NOTED.
3. 130mm $\phi$  VB SHALL BE USED ON VALVES 100mm $\phi$  TO 300mm $\phi$ .
4. GATE VALVES LARGER THAN 300mm $\phi$  SHALL USE A VALVE CHAMBER.

01	Revised April 2026				
No.	Description	No.	Description	No.	Description
Date	2026-01-21	Scale	N.T.S.	Drawn	IB



TOWN OF QUISPAMISIS

MVB COMPOSITE ADJUSTABLE VALVE BOX  
(105mm & 130mm)

Drawing

**33.SD05**

DRAWING NAME: Y:\SAINT JOHN\DATA\PROJECTS\2020\202819.00 QUISPAMIS MUNICIPAL SPECIFICATIONS\08 SPEC\CIVIL CAD DETAILS\33.SD06 GATE VALVE AND CHAMBER.DWG LAYOUT NAME: SK-9 GATE VALVE AND CHAMBER PLOT DATE: December 13, 2022 12:07:24 PM CAD OPERATOR: TRAVISM

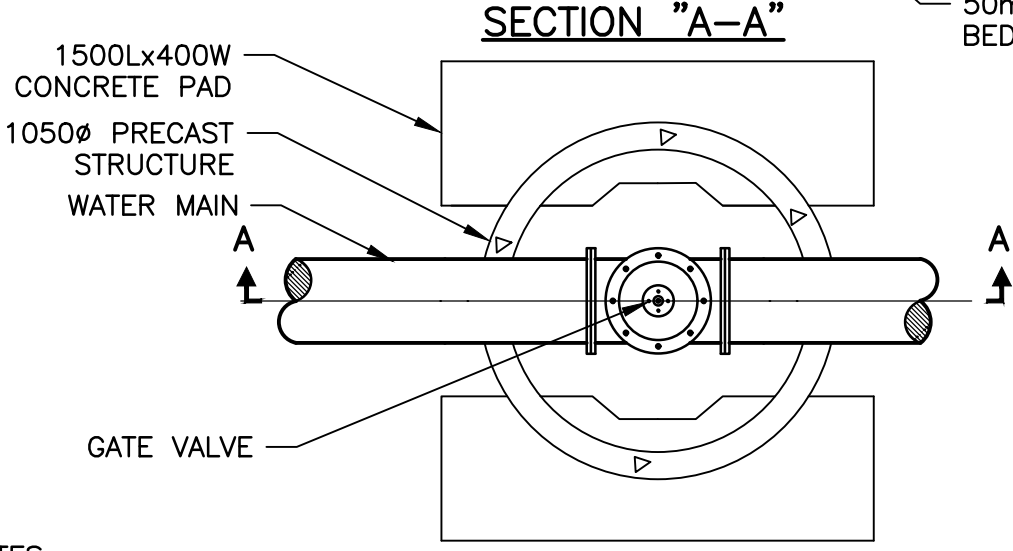
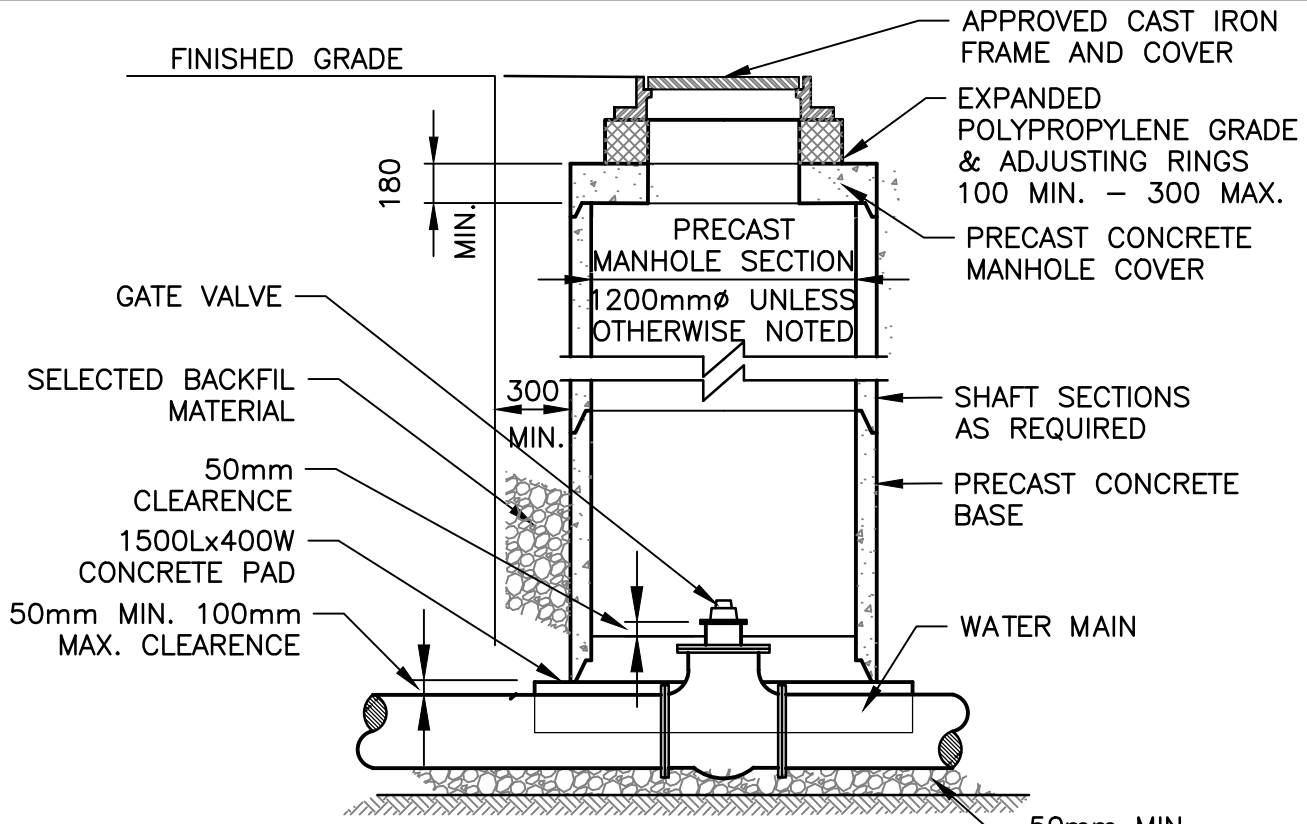

**NOTES:**

- STRUCTURE TO CONFORM TO ASTM C478.
- CONCRETE TO BE AIR ENTRAINED IN ACCORDANCE WITH CAN/CSA A23.1-M.
- ALL TRENCH WORK SHALL CONFORM TO NEW BRUNSWICK OCCUPATIONAL HEALTH AND SAFETY ACT GENERAL REGULATION 91-191 PART 12 (EXCAVATION AND TRENCHES).

**PLAN**

No.	Description	No.	Description	No.	Description
Date	2021-01-21	Scale	1:30	Drawn	THM



TOWN OF QUISPAMIS

GATE VALVE AND CHAMBER

Drawing  
**33.SD06**

DRAWING NAME: Y:\SAINT JOHN\DATA\PROJECTS\2020\2028\19.00 QUISPAMIS MUNICIPAL SPECIFICATIONS\08 SPECIFICATIONS\33.SD07 TRACER WIRE DETAIL.DWG LAYOUT NAME: SK-10 TRACER WIRE DETAIL PLOT DATE: December 13, 2022 12:13:30 PM CAD OPERATOR: TRAVISM

**NOTE:**

IN ALL GATE VALVE CHAMBERS, THE WIRE SHALL BE BROUGHT TO THE UNDERSIDE OF THE FRAME AND COVER BY ATTACHING IT TO THE SIDE OF THE CHAMBER. THIS SHALL BE DONE BY USING 13mm RIGID PVC CONDUIT AND CLAMPS FROM TOP OF THE WATER MAIN TO THE UNDERSIDE OF THE FRAME & COVER. LEAVE A MINIMUM OF 0.6m OF WIRE EXPOSED AT TOP.

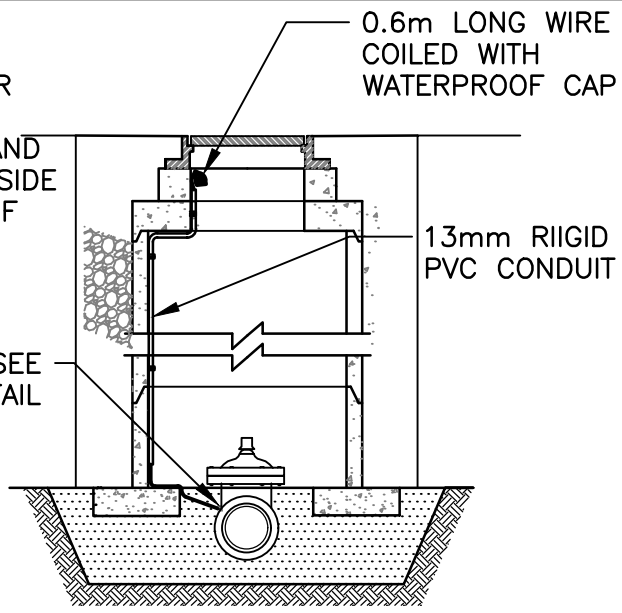
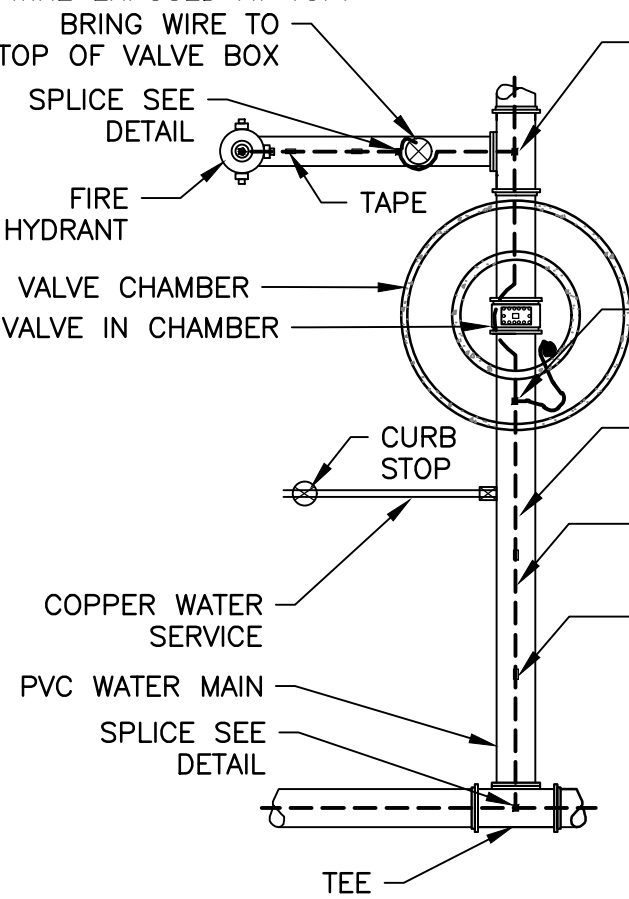

**VALVE CHAMBER**

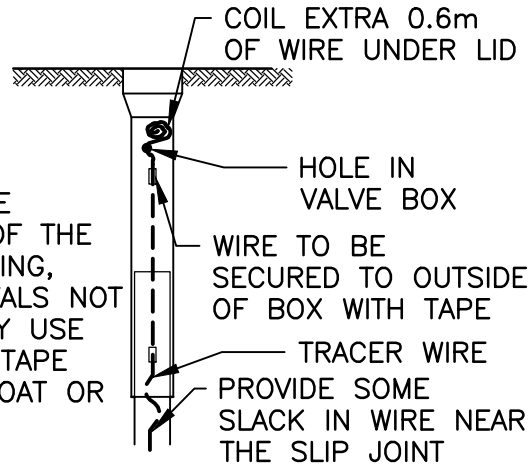

**VALVE BOXES FOR CURB STOPS & GATE VALVES**

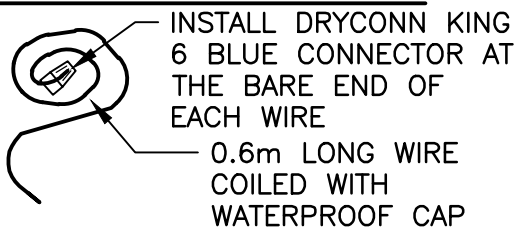
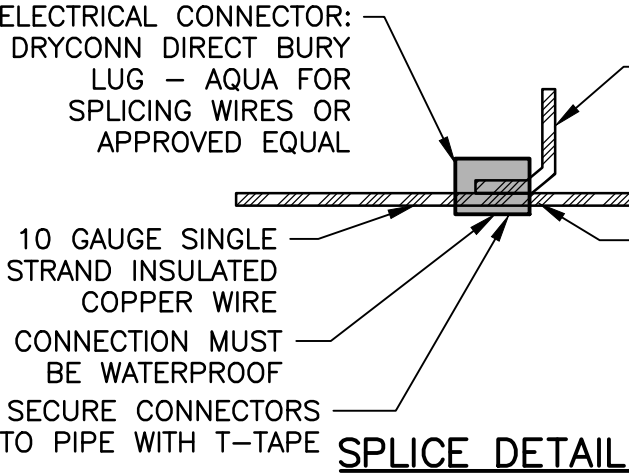

**COILED WIRE ENDS**

**NOTES:**

1. ALL CONNECTIONS MUST BE WATERPROOFED.
2. SPLICING OF TRACER WIRE IS NOT ALLOWED UNLESS SPECIFIED OR APPROVED.
3. TRACER WIRE CONTINUITY OF CURRENT MUST BE TESTED OR APPROVED.

No.	Description	No.	Description	No.	Description
Date	2021-01-21	Scale	1:40	Drawn	THM



TOWN OF QUISPAMIS

---

TRACER WIRE DETAIL

Drawing

# 33.SD07

DRAWING NAME: Y:\SAINT JOHN\DATA\PROJECTS\2020\2028\19.00 QUISPAMIS MUNICIPAL SPECIFICATIONS\08 SPEC\CIVIL CAD DETAILS\33.SD08 CHLORINATION AND FLUSHING.DWG LAYOUT NAME: SK-11 CHLORINATION AND FLUSHING PLOT DATE: December 13, 2022 12:14:44 PM CAD OPERATOR: TRAVIS M

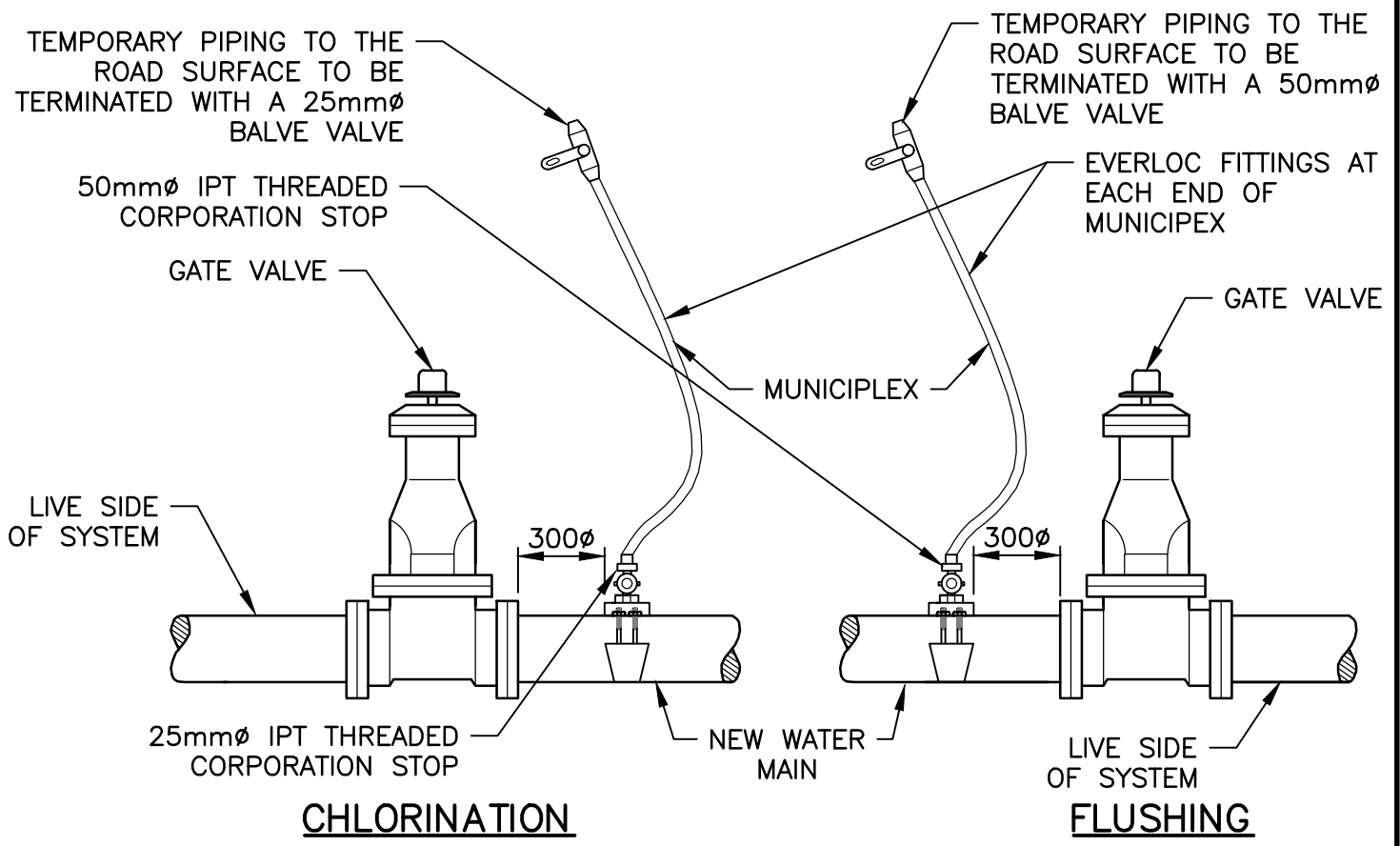

**NOTES:**

- CONTACT TOWN WATER DEPARTMENT TO PRESSURIZE LINE.
- SUCCESSFUL PRESSURE TEST IS REQUIRED BEFORE CHLORINATION CAN COMMENCE.
- TOWN WATER DEPARTMENT WILL FLUSH NEW LINES.
- TWO SUCCESSFUL BACTERIOLOGICAL TESTS ARE REQUIRED BEFORE LINE CAN BE PUT INTO SERVICE.
- TOWN WILL PUT LINES IN SERVICE.
- WHEN USING A CHAMBER, IT SHALL BE A 1200mmø MINIMUM WHEN CHLORINATION OR FLUSHING CONNECTIONS ARE REQUIRED.

No.	Description	No.	Description
Date	2021-01-21	Scale	1:25
		Drawn	THM
		TOWN OF QUISPAMIS	
CHLORINATION & FLUSHING		Drawing	
		33.SD08	

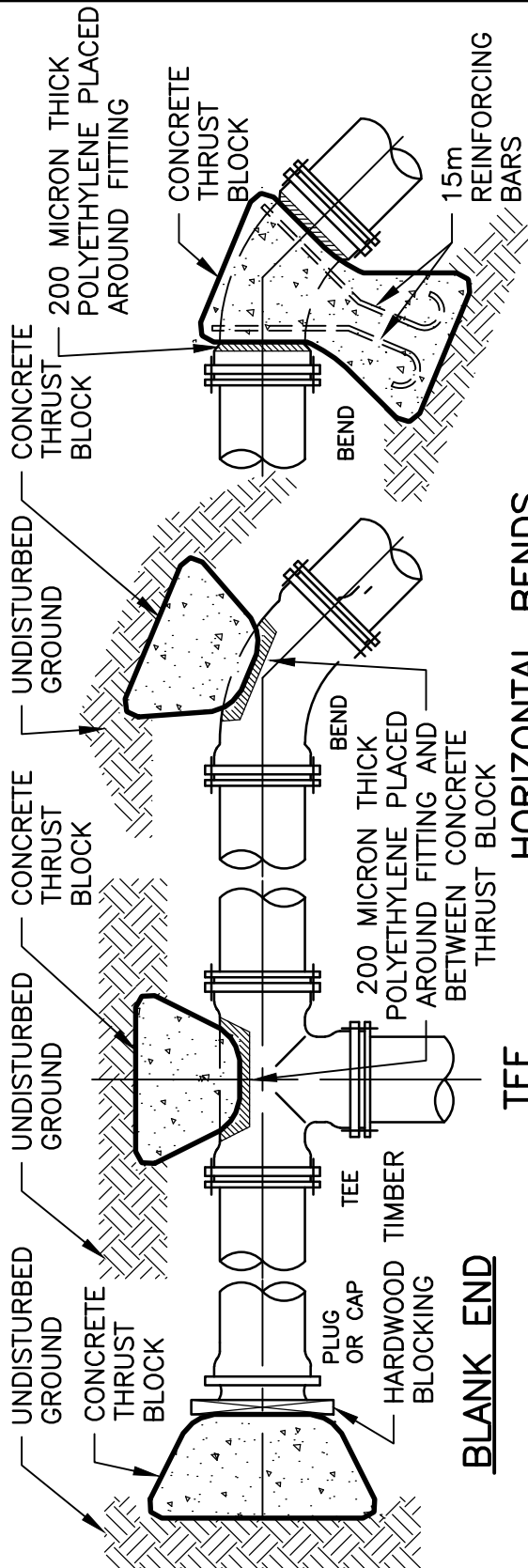

**VERTICAL BENDS**

**HORIZONTAL BENDS**

**TEE**  
MINIMUM CONTACT AREAS FOR CONC. THRUST BLOCKS

PIPE $\phi$	AREA m <sup>2</sup> FOR SOIL SUPPORTING CAPACITY OF 100 kPa
mm	CAP/PLUG TEE 90° BEND 45° BEND 22.5° BEND 1.25° BEND
100	0.25 0.32 0.20 0.16 0.16
150	0.48 0.64 0.40 0.24 0.16
200	0.80 1.12 0.64 0.32 0.16
250	1.28 1.76 0.96 0.48 0.24
300	1.76 2.56 1.44 0.72 0.40

**VERTICAL THRUST BLOCKS**  
THRUST COMPENSATED FOR  
BY MASS OF CONCRETE (m<sup>3</sup>) FITTING TO UNDISTURBED GROUND

PIPE $\phi$ mm	45° BEND	22.5° BEND	1.25° BEND
100	0.40	0.20	0.20
150	0.80	0.40	0.40
200	1.40	0.70	0.70
250	2.10	1.10	1.10
300	3.00	1.50	1.50

PIPE $\phi$ mm	mm
100	450
150	450
200	450
250	600
300	750

**NOTE:**  
CONC. COVER TO BE MIN. 75 OVER BARS AND FITTINGS

**NOTES:**

1. ALL CONCRETE 25MPa
2. REINFORCING BARS ARE TO BE PRESHAPED PRIOR TO INSTALLATION

No.	Description	No.	Description	No.	Description
Date	2021-01-21	Scale	N.T.S.	Drawn	THM



TOWN OF QUISPAMIS

CONCRETE THRUST BLOCKS

Drawing

**33.SD09**

DRAWING NAME: 1:8 ENG PUBLIC WORKS 2200-2399 ENGINEERING AND PUBLIC WORKS GENERAL 2200 CAD PROJECTS/DETAIL DRAWINGS/STANDARD DRAWINGS - CAD33.SD10 AIR RELEASE VALVE CHAMBER.DWG LAYOUT NAME: SK-13 AIR RELEASE VALVE CHAMBER PLOT DATE: March 24, 2026 4:06:24 PM CAD OPERATOR: JLEBLANC

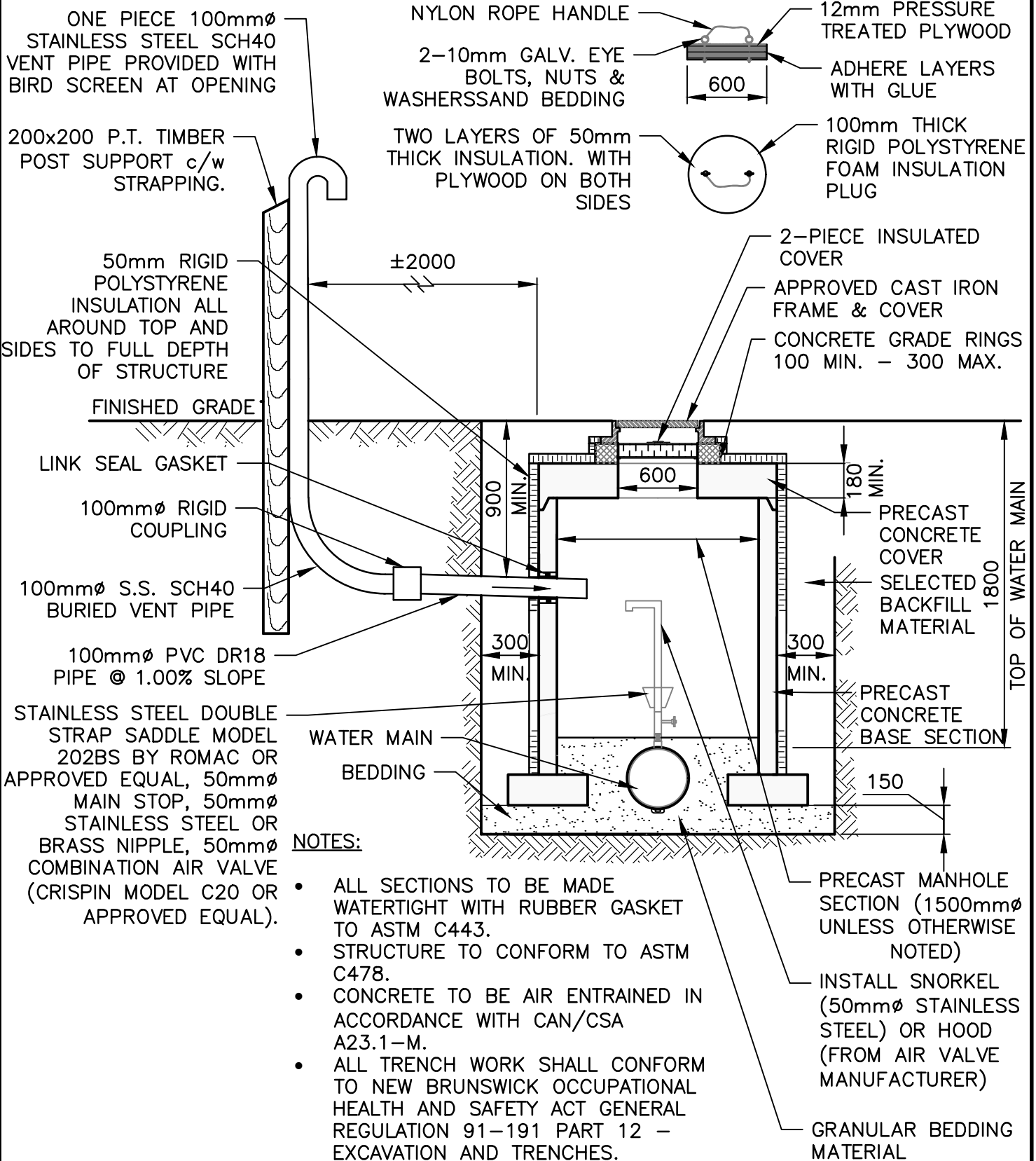

01	Revised April 2026				
No.	Description	No.	Description	No.	Description
Date	2026-02-11	Scale	N.T.S.	Drawn	JFL

<p><b>QUISPAMSIS</b> There Is No Other</p>	TOWN OF QUISPAMSIS	Drawing
	AIR RELEASE VALVE CHAMBER	

DRAWING NAME: Y:\SAINT JOHN\DATA\PROJECTS\2020\202819.00 QUISPAMIS MUNICIPAL SPECIFICATIONS\08 SPECS\CIVIL CAD DETAILS\33.SD11 WATER SERVICE CONNECTION.DWG LAYOUT NAME: SK-14 WATER SERVICE CONNECTION PLOT DATE: December 13, 2022 12:17:33 PM CAD OPERATOR: TRAVISM

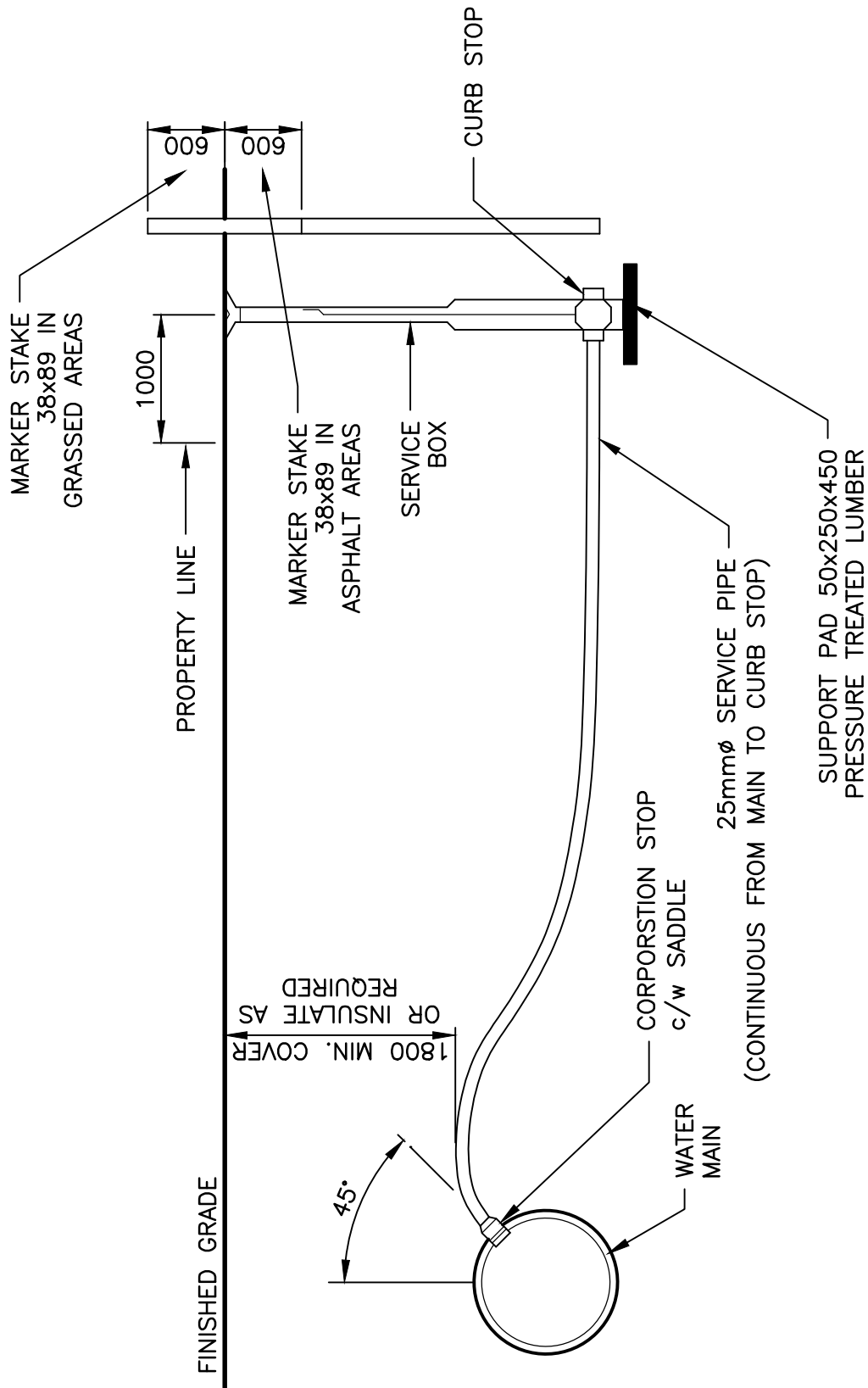

No.	Description	No.	Description	No.	Description
Date	2021-01-21	Scale	1:50	Drawn	THM



TOWN OF QUISPAMIS

WATER SERVICE CONNECTION

Drawing

**33.SD11**

DRAWING NAME: Y:\SAINT JOHN\DATA\PROJECTS\2020\202819.00 QUISPAMIS MUNICIPAL SPECIFICATIONS\08 SPECS\CIVIL CAD DETAILS\33.SD12 VALVE CHAMBER STANDARD FRAME AND COVER.DWG LAYOUT NAME: SK-15 STANDARD VC FRAME AND COVER PLOT DATE: December 13, 2022 12:29:39 PM CAD OPERATOR: TRAVISM

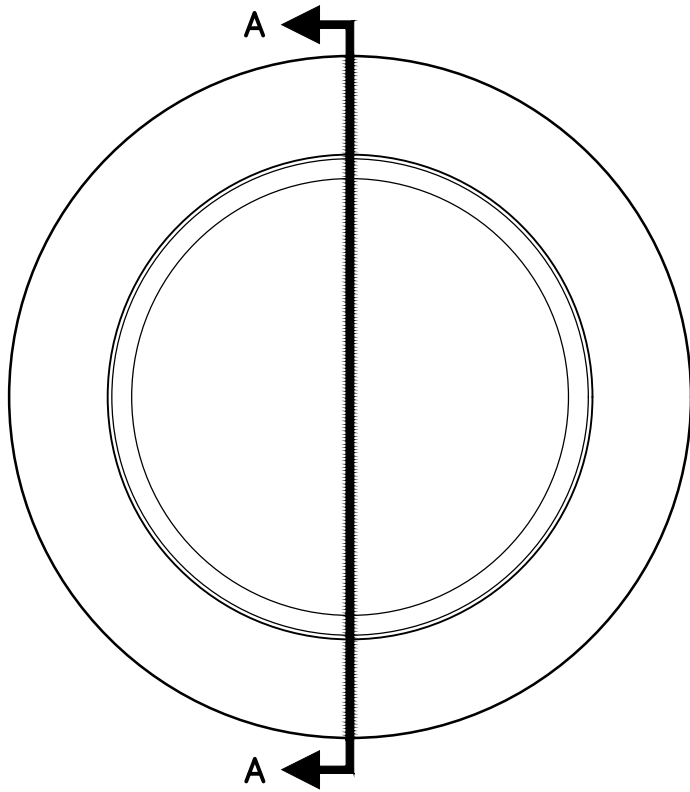

**FRAME  
TOP VIEW**

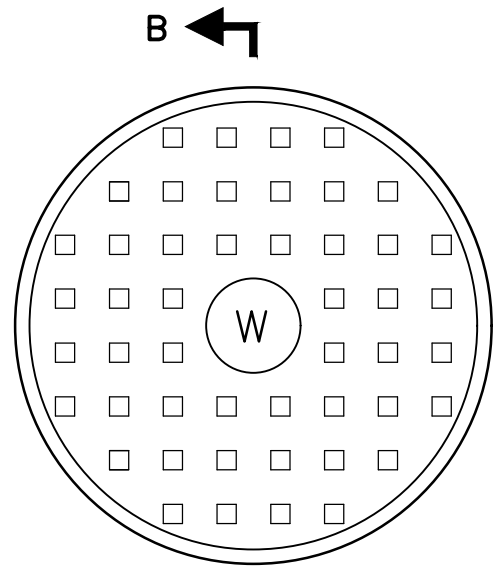

**COVER  
TOP VIEW**

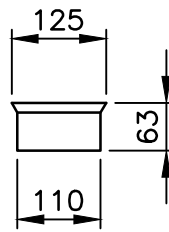

**PLUG**

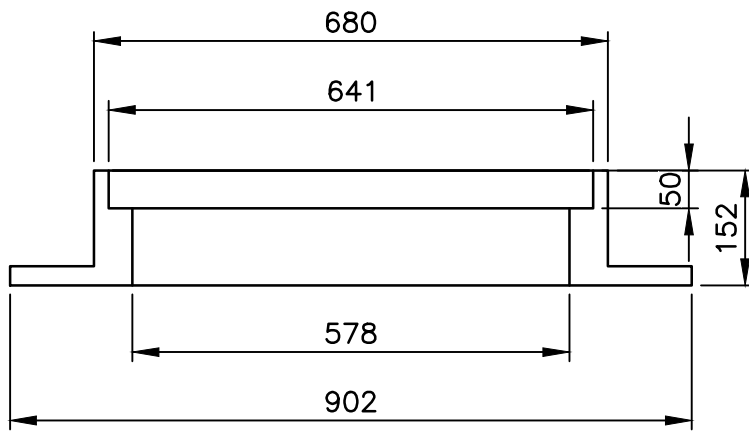

**FRAME  
SECTION "A-A"**

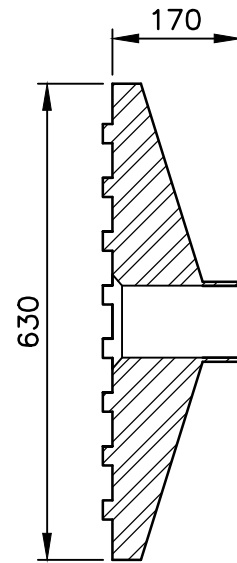

**COVER  
SECTION "B-B"**

No.	Description	No.	Description	No.	Description
Date	2021-01-21	Scale	1:10	Drawn	THM



TOWN OF QUISPAMIS

VALVE CHAMBER  
STANDARD FRAME & COVER  
(GATE VALVE)

Drawing

**33.SD12**

DRAWING NAME: Y:\SAINT JOHN\DATA\PROJECTS\2020\2028\19.00 QUISPAMIS MUNICIPAL SPECIFICATIONS\08 SPEC\CIVIL CAD DETAILS\33.SD13 VALVE CHAMBER ADJUSTABLE FRAME AND COVER.DWG LAYOUT NAME: SK-16 ADJUST VALVE CHAMBER FRAME AND COVER.PLOT DATE: December 13, 2022 12:31:01 PM CAD OPERATOR: TRAVIS

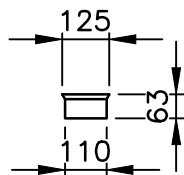

**PLUG**

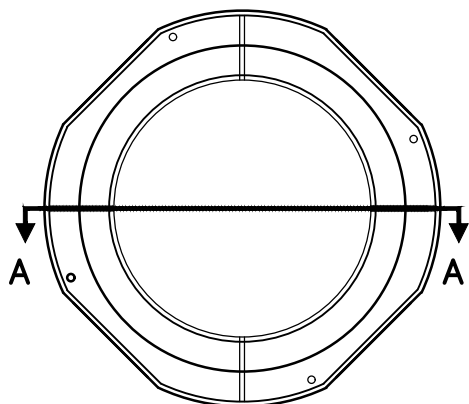
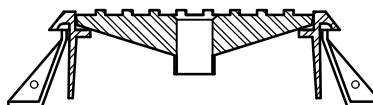

**CONICAL GUIDE**

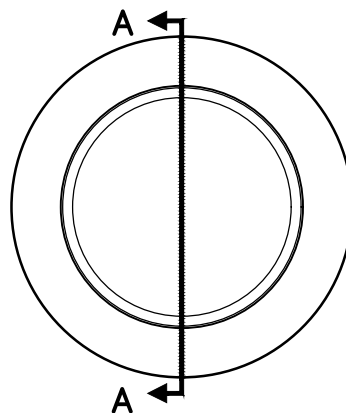

**FRAME  
TOP VIEW**

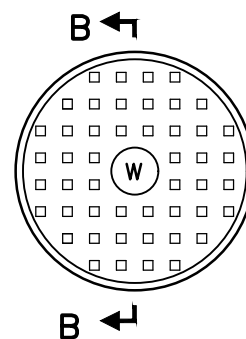

**COVER  
TOP VIEW**

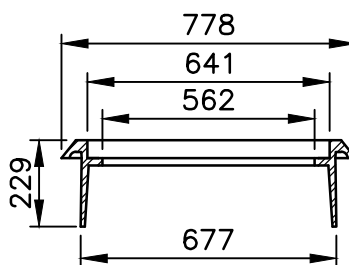
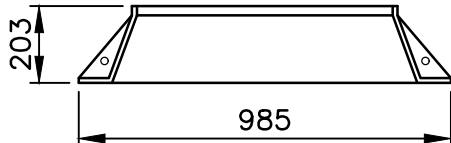

**FRAME  
SECTION "A-A"**

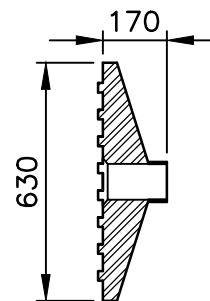

**COVER  
SECTION "B-B"**

No.	Description	No.	Description	No.	Description
Date	2021-01-21	Scale	1:20	Drawn	THM



TOWN OF QUISPAMIS

VALVE CHAMBER  
ADJUSTABLE FRAME & COVER  
(GATE VALVE)

Drawing

**33.SD13**

DRAWING NAME: Y:\SAINT JOHN\DATA\PROJECTS\2020\202819.00 QUISPAMIS MUNICIPAL SPECIFICATIONS\08 SPEC\CIVIL CAD DETAILS\33.SD14 SANITARY MANHOLE.DWG LAYOUT NAME: SK-17 SANITARY MANHOLE PLOT DATE: December 13, 2022 12:32:15 PM CAD OPERATOR: TRAVIS

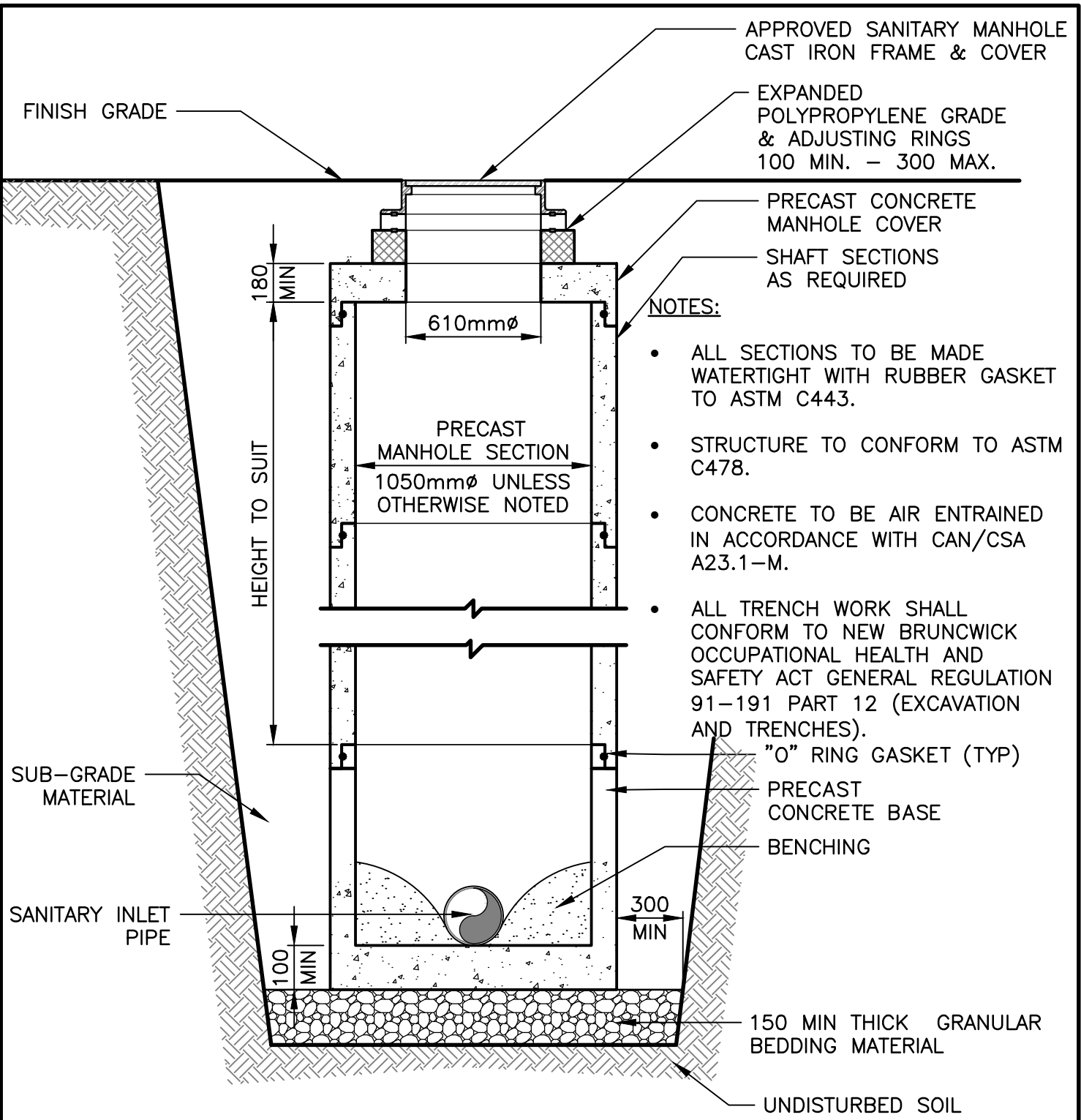

- NOTES:**
- ALL SECTIONS TO BE MADE WATERTIGHT WITH RUBBER GASKET TO ASTM C443.
  - STRUCTURE TO CONFORM TO ASTM C478.
  - CONCRETE TO BE AIR ENTRAINED IN ACCORDANCE WITH CAN/CSA A23.1-M.
  - ALL TRENCH WORK SHALL CONFORM TO NEW BRUNSWICK OCCUPATIONAL HEALTH AND SAFETY ACT GENERAL REGULATION 91-191 PART 12 (EXCAVATION AND TRENCHES).

No.	Description	No.	Description	No.	Description
Date	2021-01-21	Scale	1:25	Drawn	THM
			TOWN OF QUISPAMIS		Drawing
			SANITARY MANHOLE		<b>33.SD14</b>

DRAWING NAME: Y:\SAINT JOHN\DATA\PROJECTS\2020\2028\19.00 QUISPAMIS MUNICIPAL SPECIFICATIONS\08 SPEC\CVIL CAD DETAILS\33.SD15 INTERIOR DROP MANHOLE.DWG LAYOUT NAME: SK-18 INTERIOR DROP MANHOLE PLOT DATE: December 13, 2022 12:33:25 PM CAD OPERATOR: TRAVISM

ATTACH BRACKET TO MANHOLE WITH HILTI 6mmØ. 18-8 STAINLESS STEEL DROP-IN ANCHORS AND BOLTS. 2 ANCHORS EACH BRACKET.

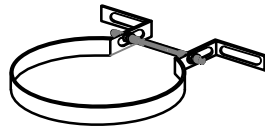

3mm THK x 25mm WIDE 11 GAUGE STAINLESS STEEL BRACKETS.

11 GAUGE 304 STAINLESS STEEL

**BRACKET DETAIL**

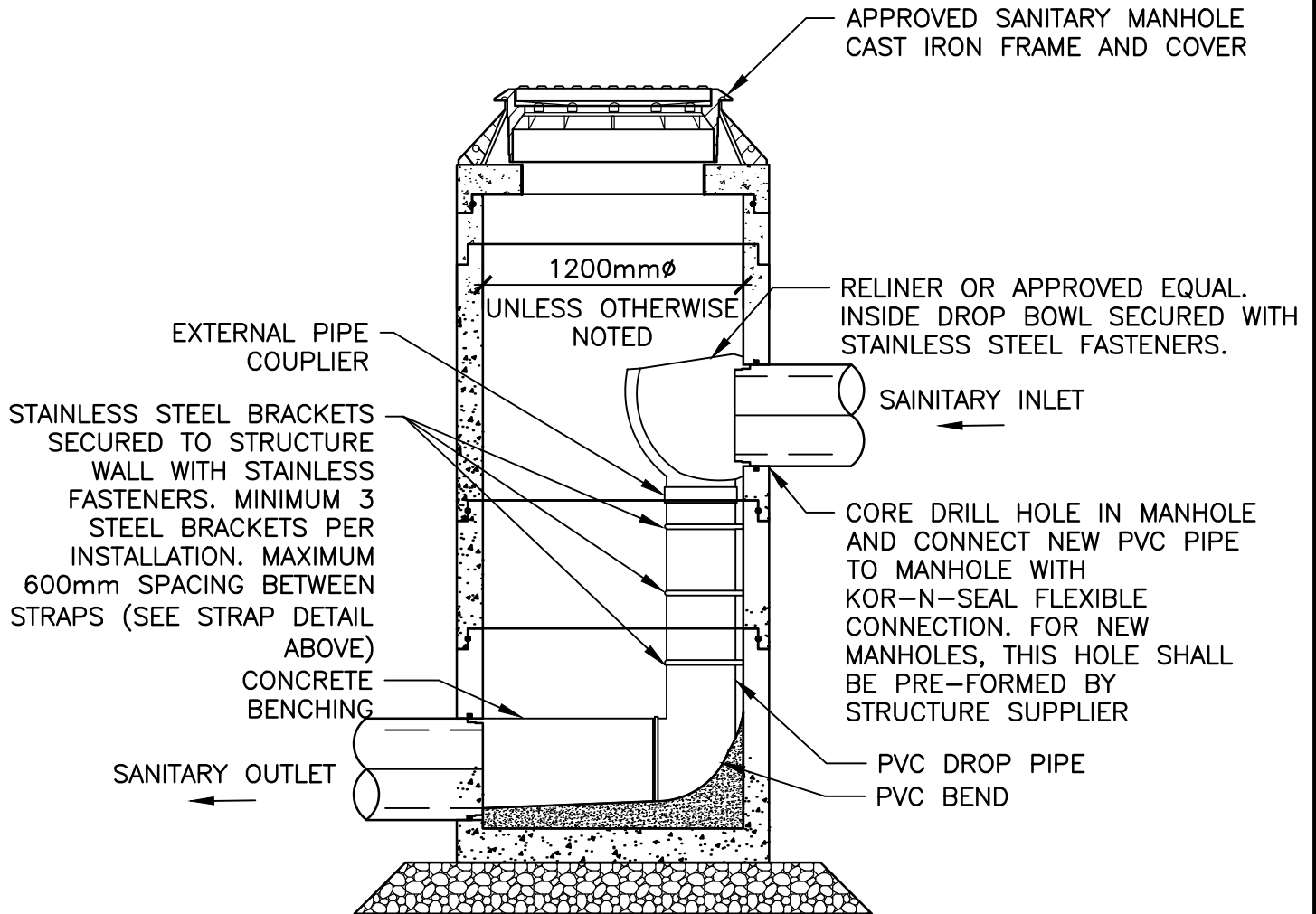

**NOTES:**

1. ALL DIMENSIONS ARE IN MILLIMETERS.
2. STRUCTURE TO CONFORM TO CSA A257.4.
3. CONCRETE TO BE AIR ENTRAINED IN ACCORDANCE WITH CSA A23.1
4. INTERIOR DROP DIMENSIONS FOR EACH APPLICATION TO BE SPECIFIED BY THE ENGINEER.

No.	Description	No.	Description
Date	2021-01-21	Scale	1:40
		Drawn	THM
		TOWN OF QUISPAMIS	
INTERIOR DROP MANHOLE		Drawing	
		33.SD15	

DRAWING NAME: Y:\SAINT JOHN\DATA\PROJECTS\2020\202819.00 QUISPAMIS MUNICIPAL SPECIFICATIONS\08 SPEC\CIVIL CAD DETAILS\33.SD16 SANITARY SERVICE CONNECTION.DWG LAYOUT NAME: SK-19 SANITARY SERVICE CONNECTION PLOT DATE: December 13, 2022 12:34:33 PM CAD OPERATOR: TRAVIS M

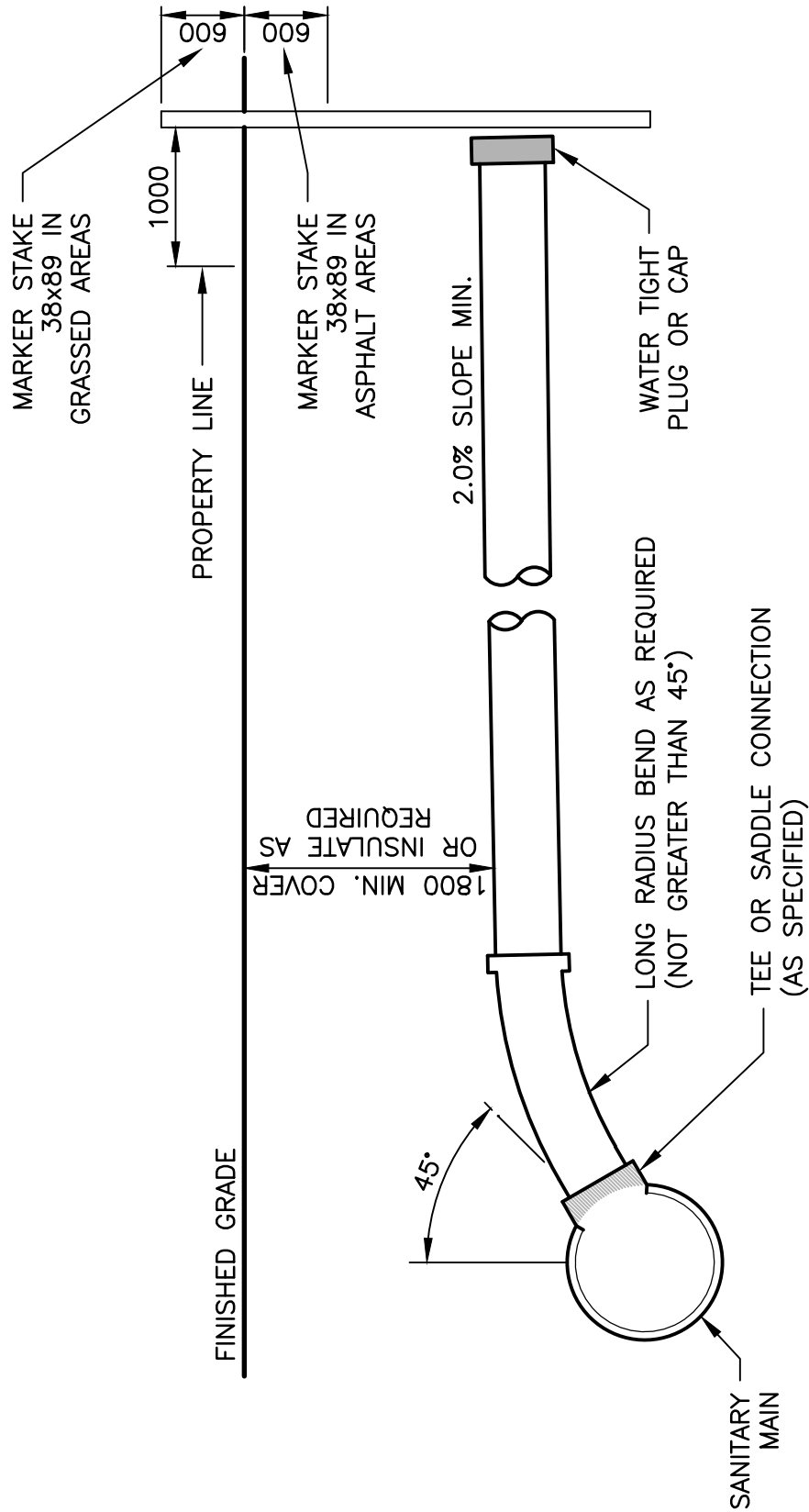

No.	Description	No.	Description	No.	Description
Date	2021-01-21	Scale	1:50	Drawn	THM



TOWN OF QUISPAMIS

SANITARY SERVICE CONNECTION

Drawing

**33.SD16**

DRAWING NAME: Y:\SAINT JOHN\DATA\PROJECTS\2020\202819.00 QUIPAMSIS MUNICIPAL SPECIFICATIONS\08 SPEC\CIVIL CAD DETAILS\33.SD17 STANDARD SANITARY MANHOLE FRAME AND COVER.DWG LAYOUT NAME: SK-20 SANITARY STANDARD MANHOLE FRAME AND COVER PLOT DATE: December 13, 2022 12:35:33 PM CAD OPERATOR

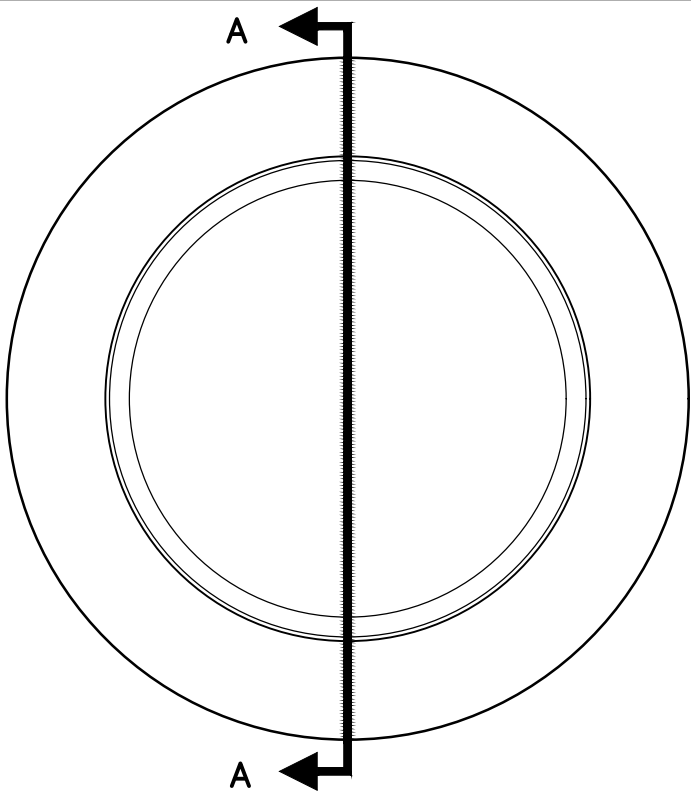

FRAME  
TOP VIEW

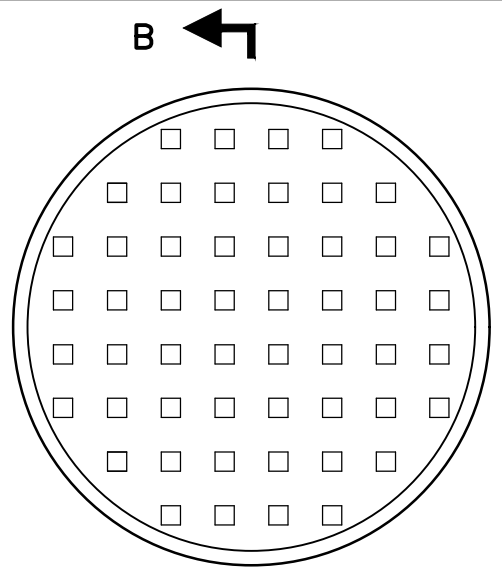

COVER  
TOP VIEW

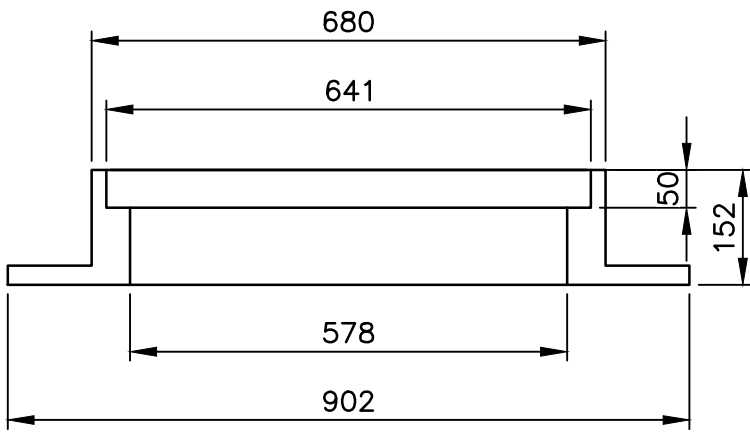

FRAME  
SECTION "A-A"

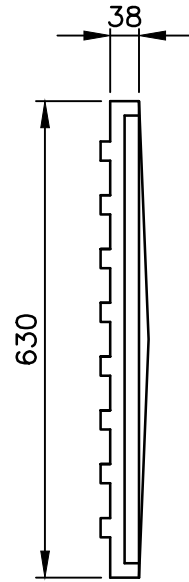

COVER  
SECTION "B-B"

No.	Description	No.	Description	No.	Description
Date	2021-01-21	Scale	1:10	Drawn	THM



TOWN OF QUIPAMSIS

SANITARY  
STANDARD MANHOLE  
FRAME & COVER

Drawing

**33.SD17**

DRAWING NAME: Y:\SAINT JOHN\DATA\PROJECTS\2020\202819.00 QUIPAMSIS MUNICIPAL SPECIFICATIONS\08 SPEC\CIVIL CAD DETAILS\33.SD18 SANITARY MANHOLE ADJUSTABLE FRAME AND COVER.PLOT DATE: December 13, 2022 12:37:35 PM CAD OPERATOR

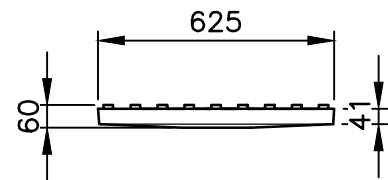
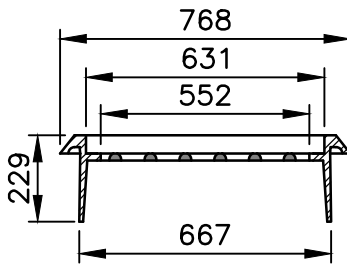
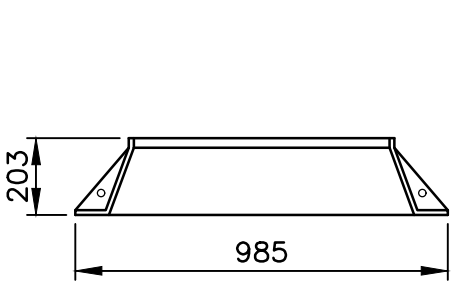
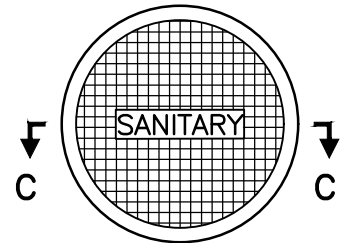
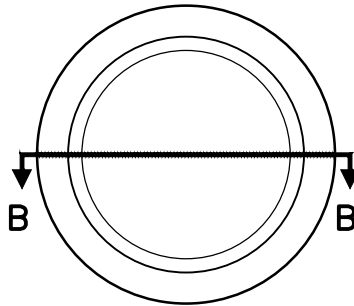
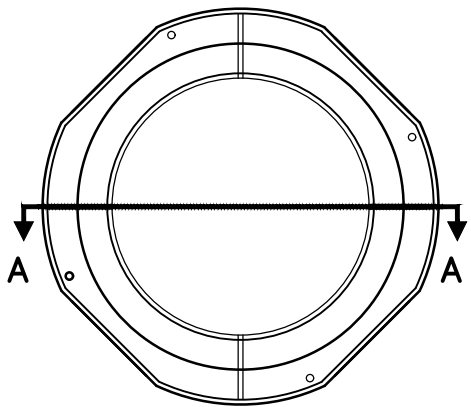

**CONICAL GUIDE**

**FRAME**

**COVER**

No.	Description	No.	Description	No.	Description
Date	2021-01-21	Scale	1:20	Drawn	THM



TOWN OF QUIPAMSIS

SANITARY MANHOLE  
ADJUSTABLE  
FRAME & COVER

Drawing

**33.SD18**

DRAWING NAME: Y:\SAINT JOHN\DATA\PROJECTS\2020\202819.00 QUISPAMISIS MUNICIPAL SPECIFICATIONS\08 SPEC\CVIL CAD DETAILS\33.SD19 STORM MANHOLE.DWG LAYOUT NAME: SK-22 STORM MANHOLE PLOT DATE: December 13, 2022 12:38:32 PM CAD OPERATOR: TRAVISM

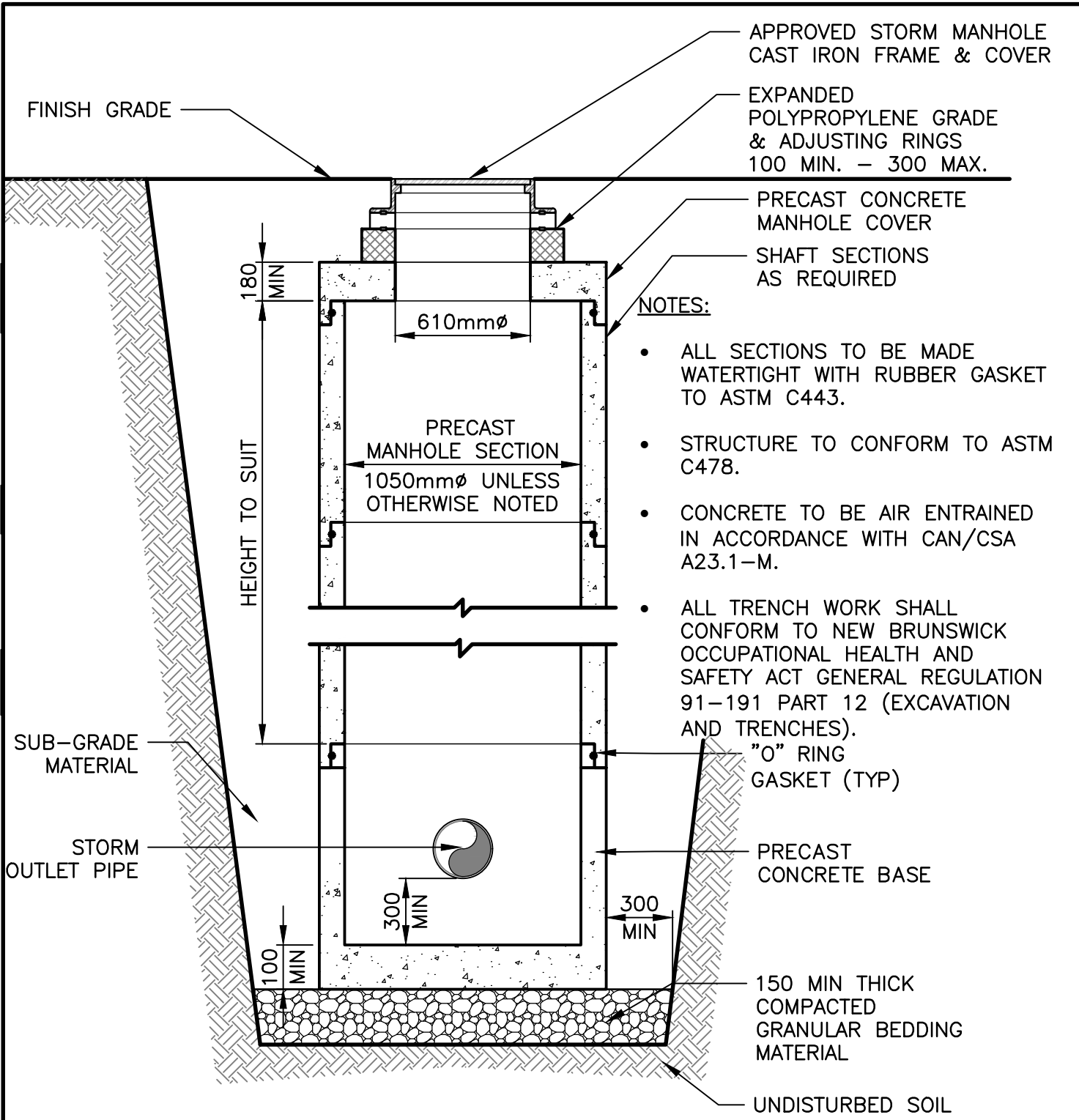

- NOTES:**
- ALL SECTIONS TO BE MADE WATERTIGHT WITH RUBBER GASKET TO ASTM C443.
  - STRUCTURE TO CONFORM TO ASTM C478.
  - CONCRETE TO BE AIR ENTRAINED IN ACCORDANCE WITH CAN/CSA A23.1-M.
  - ALL TRENCH WORK SHALL CONFORM TO NEW BRUNSWICK OCCUPATIONAL HEALTH AND SAFETY ACT GENERAL REGULATION 91-191 PART 12 (EXCAVATION AND TRENCHES).

No.	Description	No.	Description	No.	Description
Date	2021-01-21	Scale	1:25	Drawn	THM
			TOWN OF QUISPAMISIS		Drawing
			STORM MANHOLE		<b>33.SD19</b>

DRAWING NAME: Y:\SAINT JOHN\DATA\PROJECTS\2020\202819.00 QUISPAMIS MUNICIPAL SPECIFICATIONS\08 SPEC\08 SPEC\CIVIL CAD DETAILS\33.SD20 CATCH BASIN.DWG LAYOUT NAME: SK-23 CATCH BASIN PLOT DATE: December 13, 2022 12:39:24 PM CAD OPERATOR: TRAVIS M

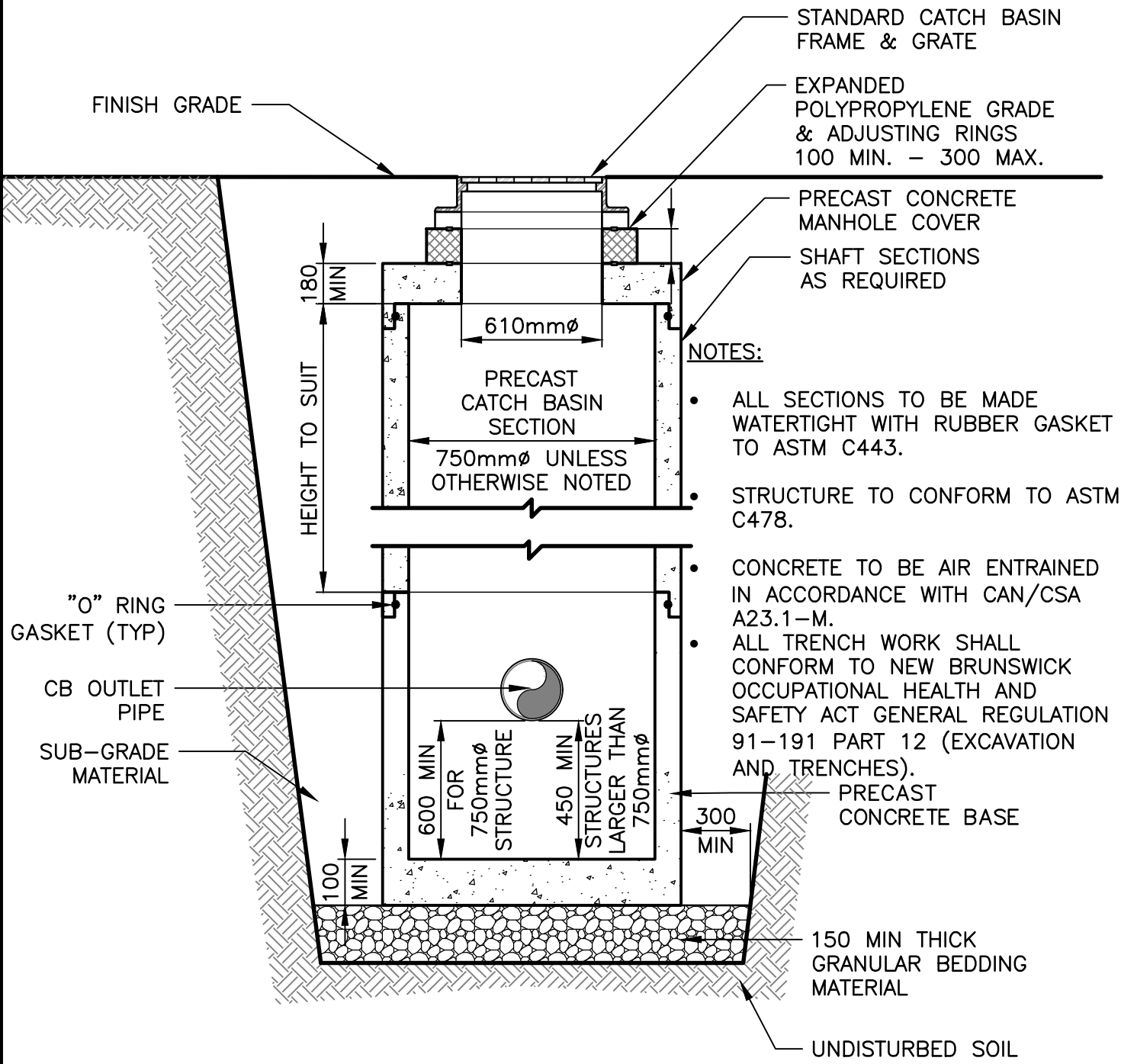

No.	Description	No.	Description	No.	Description
Date	2021-01-21	Scale	1:25	Drawn	THM



TOWN OF QUISPAMIS

CATCH BASIN

Drawing

**33.SD20**

DRAWING NAME: Y:\SAINT JOHN\DATA\PROJECTS\2020\2028\19.00 QUISPAMIS MUNICIPAL SPECIFICATIONS\08 SPEC\CVIL CAD DETAILS\33.SD21 CATCH BASIN AT CURB-CURB AND GUTTER.DWG LAYOUT NAME: SK-24 CATCH BASIN AT CURB-CURB AND GUTTER PLOT DATE: December 13, 2022 12:40:17 PM CAD OPERATOR: TRAVISM

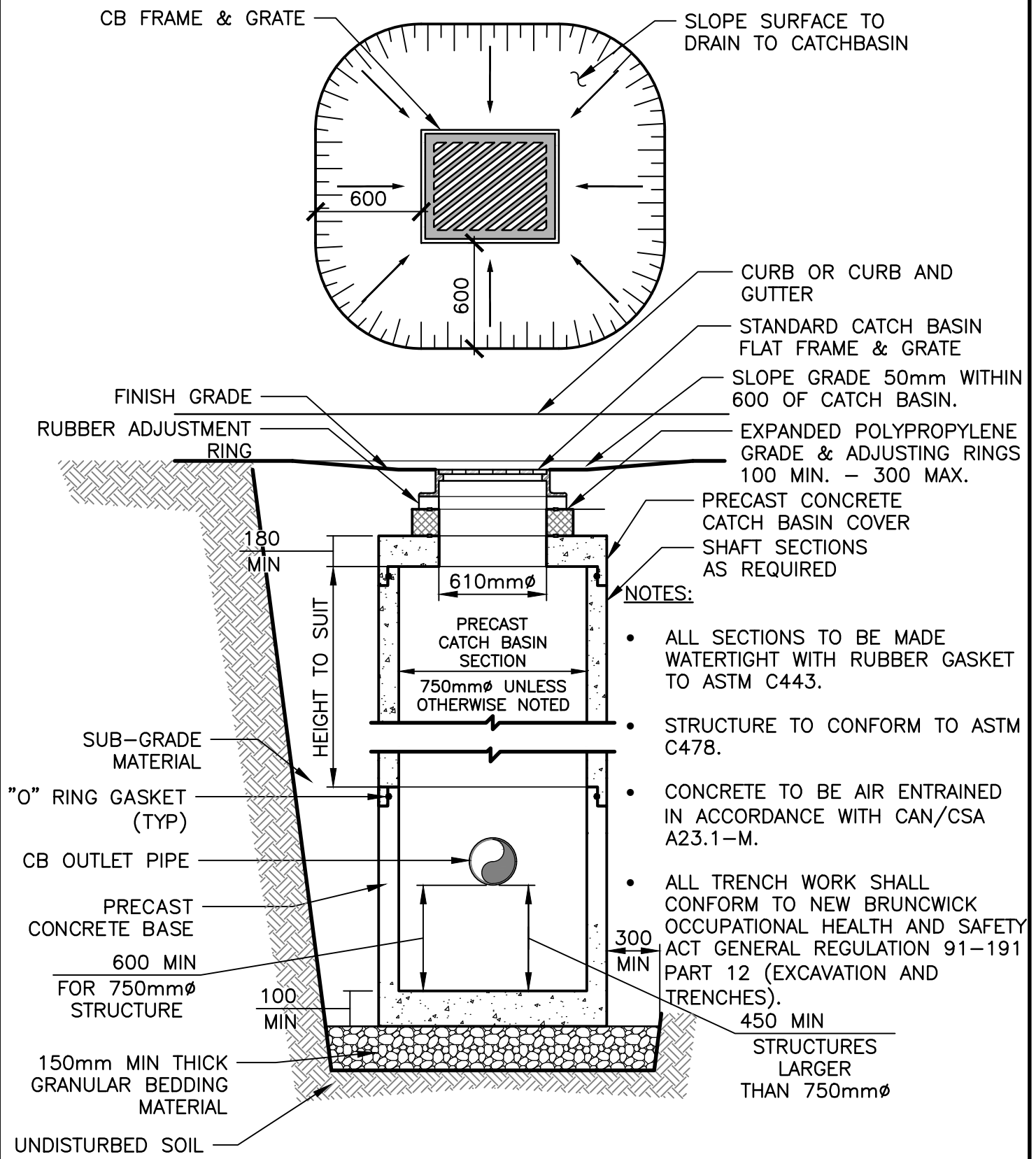

No.	Description	No.	Description	No.	Description
Date	2021-01-21	Scale	1:30	Drawn	THM



TOWN OF QUISPAMIS  
CATCH BASIN  
AT CURB OR CURB AND GUTTER

Drawing

33.SD21

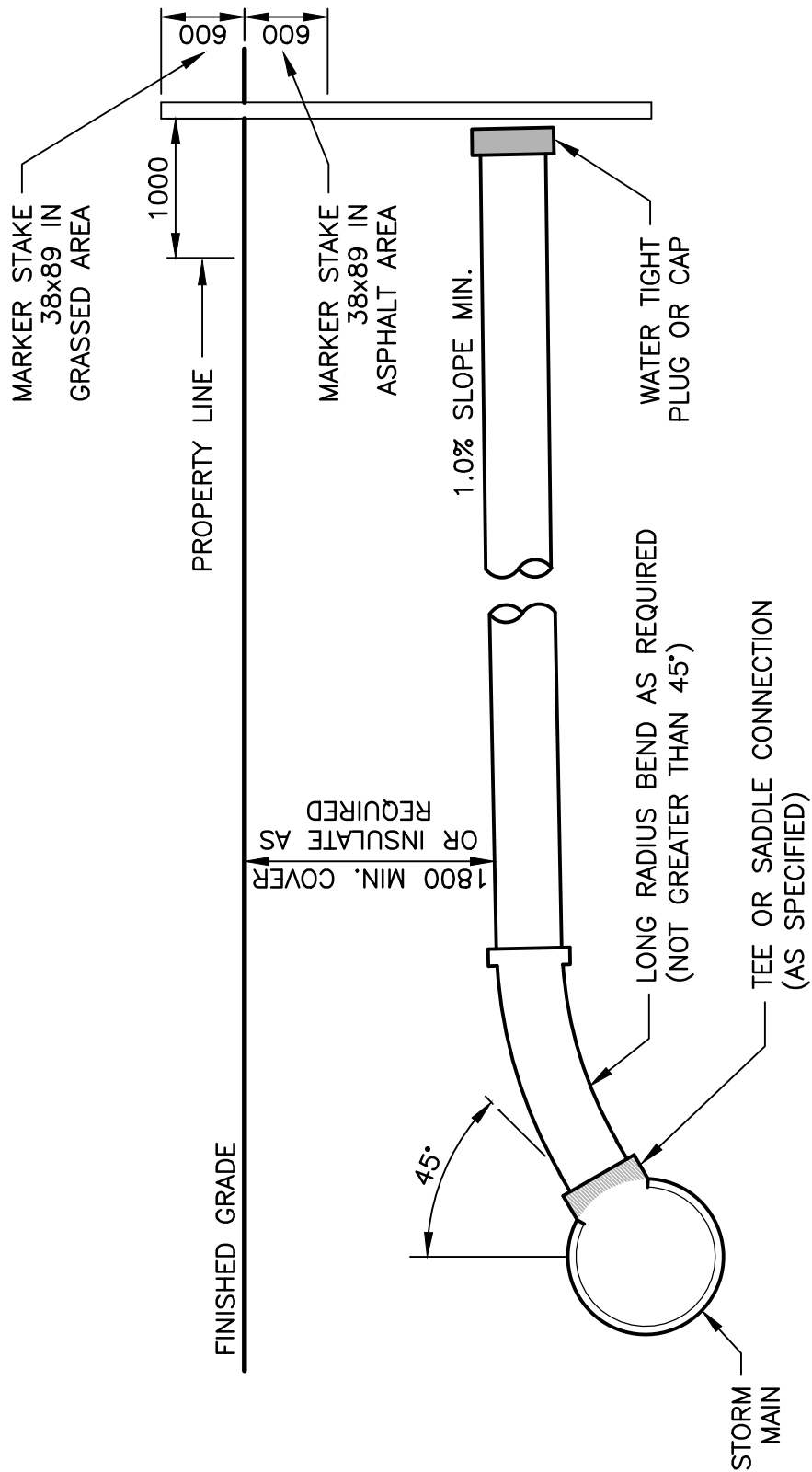

No.	Description	No.	Description	No.	Description
Date	2021-01-21	Scale	1:50	Drawn	THM



TOWN OF QUISPAMISIS

STORM SERVICE CONNECTION

Drawing

**33.SD022**

DRAWING NAME: Y:\SAINT JOHN\DATA\PROJECTS\2020\202819.00 QUISPAMSI MUNICIPAL SPECIFICATIONS\08 SPEC\CIVIL CAD DETAILS\33.SD23 STORM MANHOLE STANDARD FRAME AND COVER.DWG LAYOUT NAME: SK-26 STORM MANHOLE STANDARD FRAME AND COVER PLOT DATE: December 13, 2022 12:43:38 PM CAD OPERATOR:

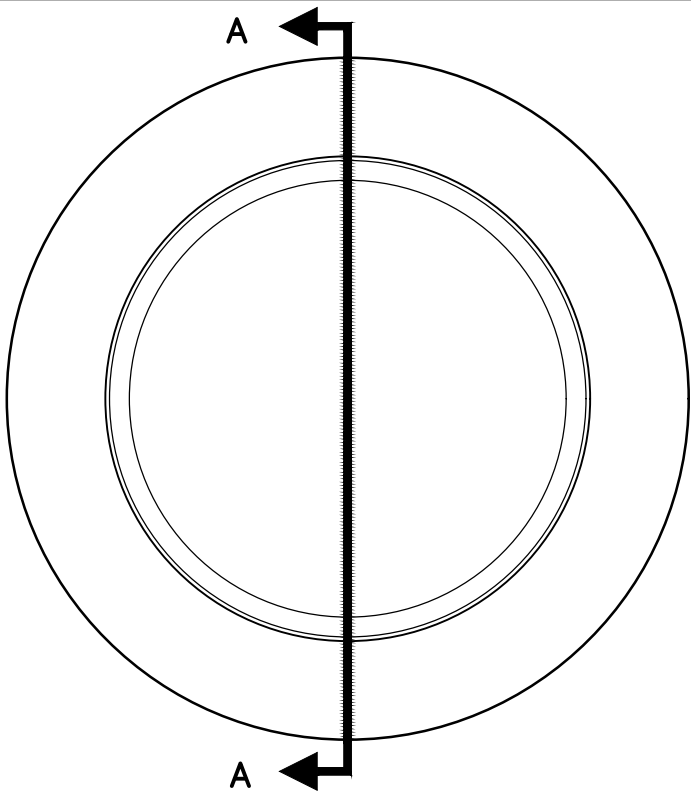

FRAME  
TOP VIEW

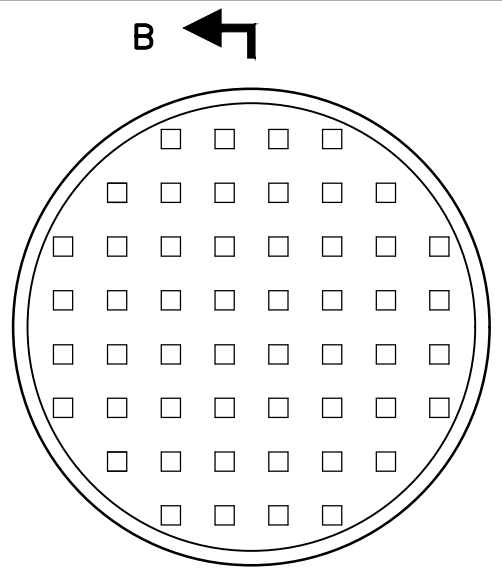

COVER  
TOP VIEW

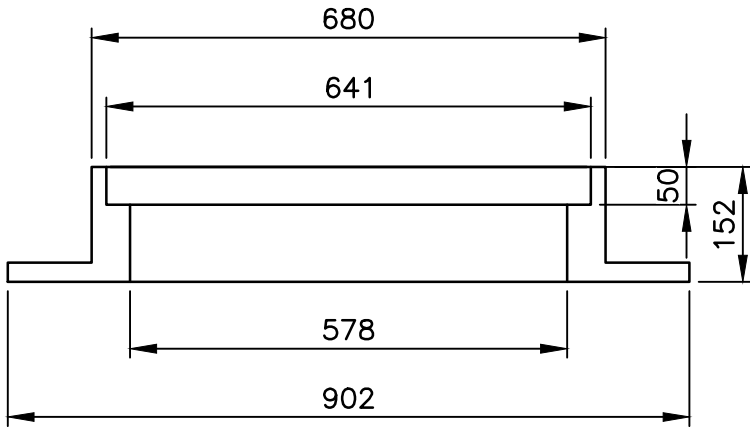

FRAME  
SECTION "A-A"

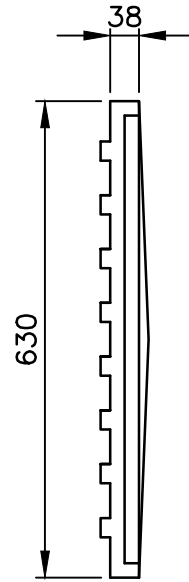

COVER  
SECTION "B-B"

No.	Description	No.	Description	No.	Description
Date	2021-01-21	Scale	1:10	Drawn	THM



TOWN OF QUISPAMSI

STORM MANHOLE  
STANDARD  
FRAME & COVER

Drawing

**33.SD23**

DRAWING NAME: Y:\SAINT JOHN\DATA\PROJECTS\2020\202819.00 QUISPAMIS MUNICIPAL SPECIFICATIONS\08 SPEC\CIVIL CAD DETAILS\33.SD24 STORM MANHOLE ADJUSTABLE FRAME AND COVER.DWG LAYOUT NAME: SK-27 STORM MANHOLE ADJUSTABLE FRAME AND COVER.PLOT DATE: December 13, 2022 12:44:34 PM CAD OPERATOR:

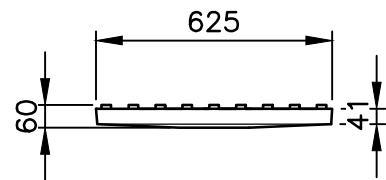
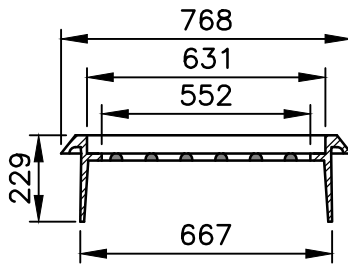
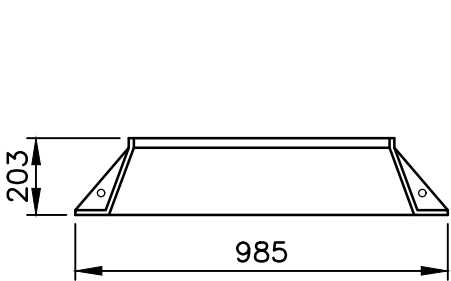
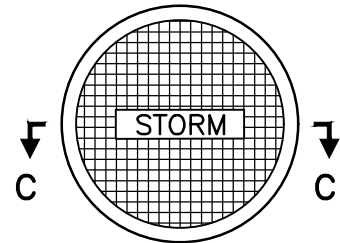
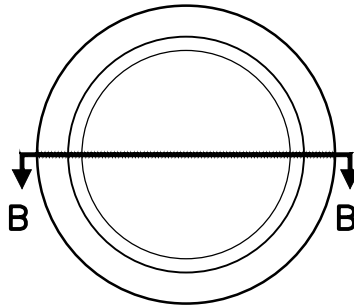
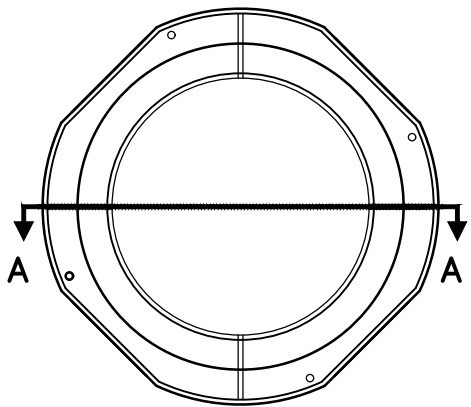

**CONICAL GUIDE**

**FRAME**

**COVER**

No.	Description	No.	Description	No.	Description
Date	2021-01-21	Scale	1:20	Drawn	THM



TOWN OF QUISPAMIS

STORM MANHOLE  
ADJUSTABLE  
FRAME & COVER

Drawing

**33.SD24**

DRAWING NAME: Y:\SAINT JOHN\DATA\PROJECTS\2020\202819.00 QUISPAMISIS MUNICIPAL SPECIFICATIONS\08 SPECS\CIVIL CAD DETAILS\33.SD25 CATCH BASIN STANDARD FRAME AND FLAT GRATE.DWG LAYOUT NAME: SK-28 CATCH BASIN STANDARD FRAME AND FLAT GRATE PLOT DATE: December 13, 2022 12:45:28 PM CAD OPERATOR:

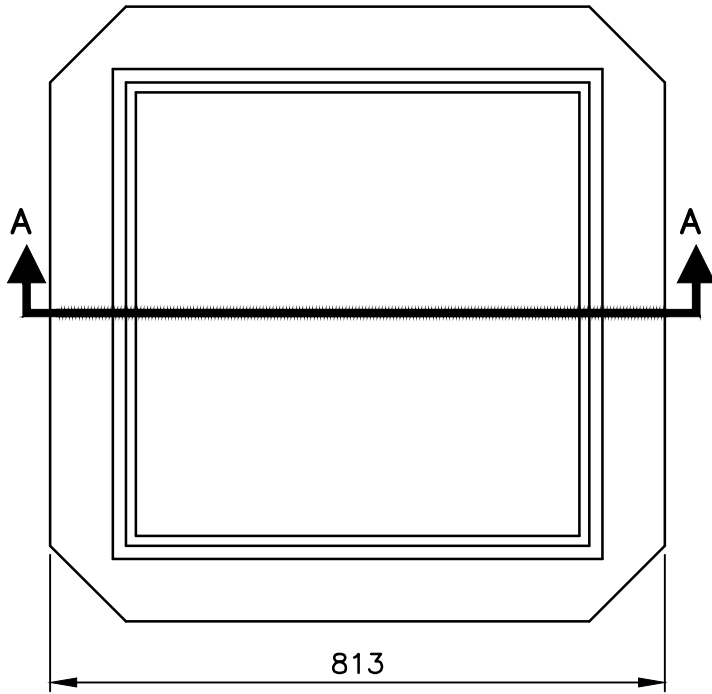
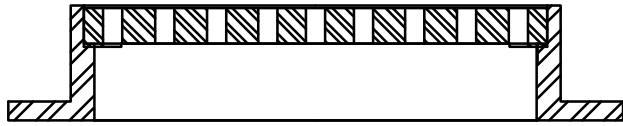

**FRAME  
TOP VIEW**

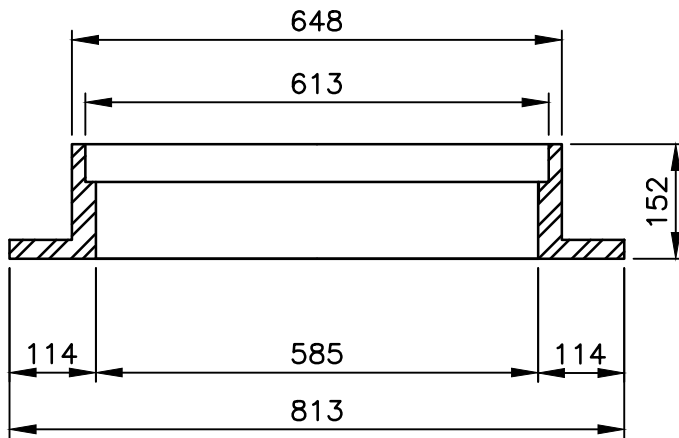

**FRAME  
SECTION "A-A"**

**B ←**

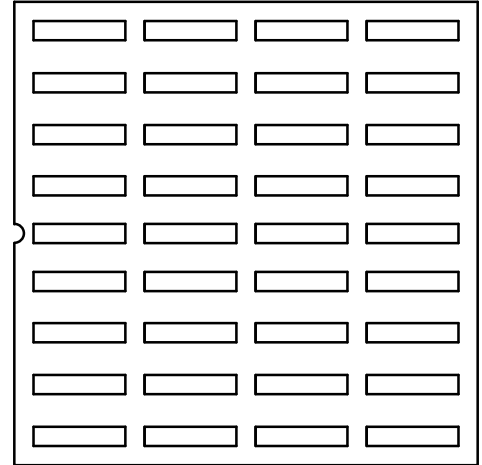

**B ←**

**COVER  
TOP VIEW**

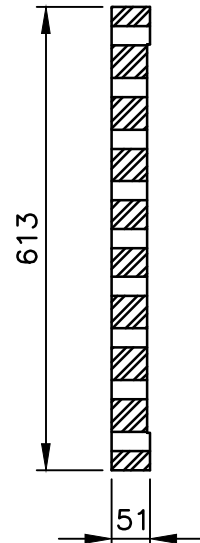

**COVER  
SECTION "B-B"**

No.	Description	No.	Description	No.	Description
Date	2021-01-21	Scale	1:10	Drawn	THM



TOWN OF QUISPAMISIS

CATCH BASIN  
STANDARD  
FRAME & FLAT GRATE

Drawing

**33.SD25**

DRAWING NAME: Y:\SAINT JOHN\DATA\PROJECTS\2020\202819.00 QUISPAMIS MUNICIPAL SPECIFICATIONS\08 SPECS\CIVIL CAD DETAILS\33.SD26 CATCH BASIN PYRAMID FRAME AND COVER.DWG LAYOUT NAME: SK-29 CATCH BASIN PYRAMID FRAME AND COVER.PLOT DATE: December 13, 2022 12:46:21 PM CAD OPERATOR: TRAVIS M

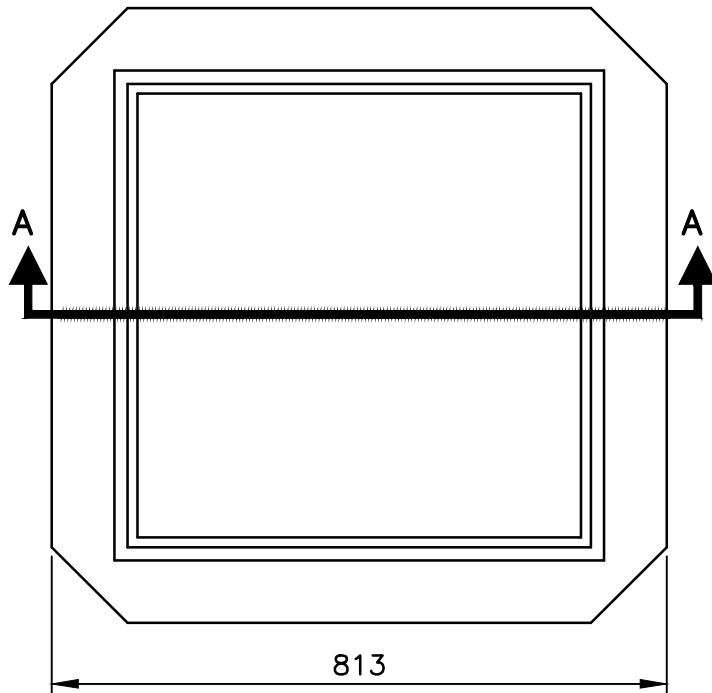

**FRAME  
TOP VIEW**

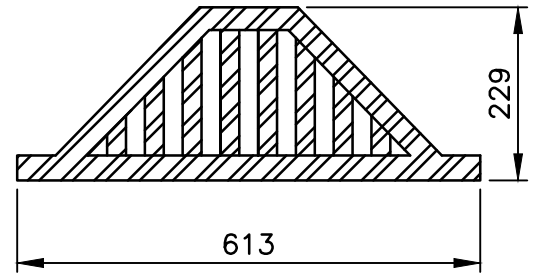

**COVER  
SECTION "B-B"**

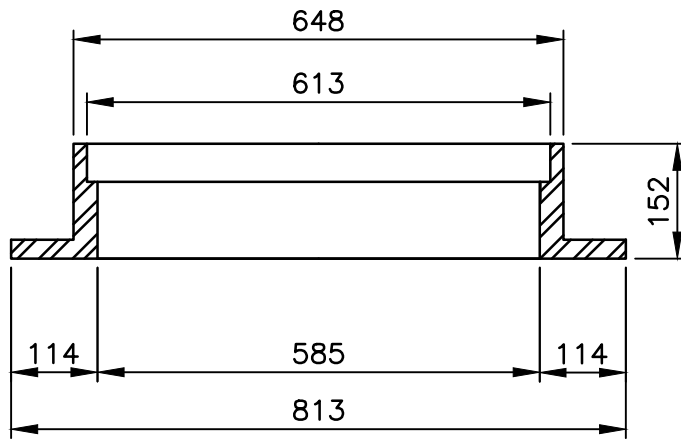

**FRAME  
SECTION "A-A"**

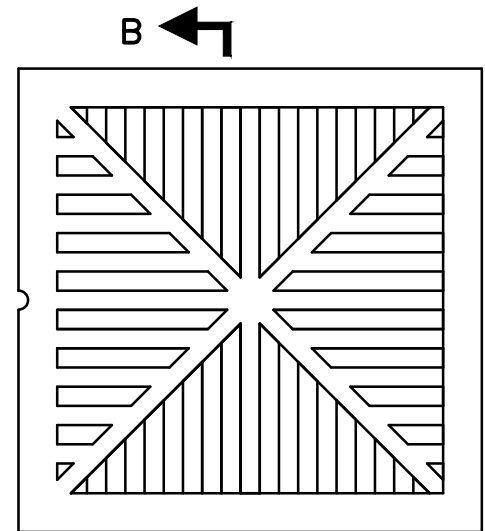

**COVER  
TOP VIEW**

No.	Description	No.	Description	No.	Description
Date	2021-01-21	Scale	1:10	Drawn	THM



TOWN OF QUISPAMIS

CATCH BASIN  
PYRAMID  
FRAME & COVER

Drawing

**33.SD26**

DRAWING NAME: Y:\SAINT JOHN\DATA\PROJECTS\2020\202819.00 QUISPAMIS MUNICIPAL SPECIFICATIONS\08 SPECS\CIVIL CAD DETAILS\33.SD27 CULVERT INLET GRATE.DWG LAYOUT NAME: SK-30 CULVERT INLET GRATE PLOT DATE: December 13, 2022 12:47:10 PM CAD OPERATOR: TRAVISM

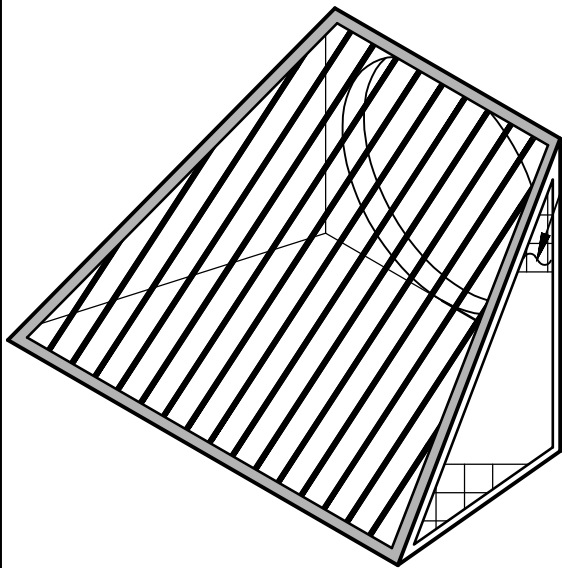

L50x50x10  
STEEL ANGLE

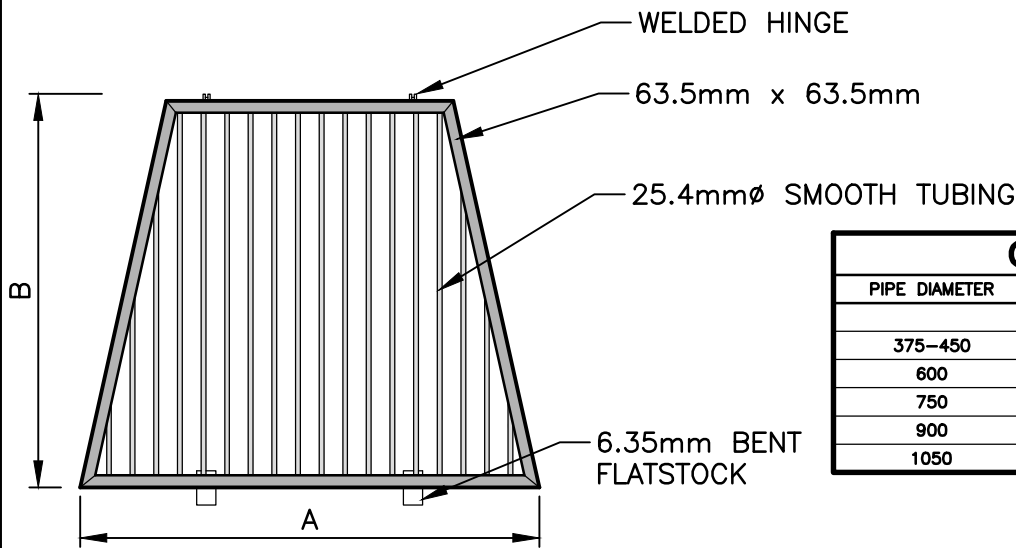
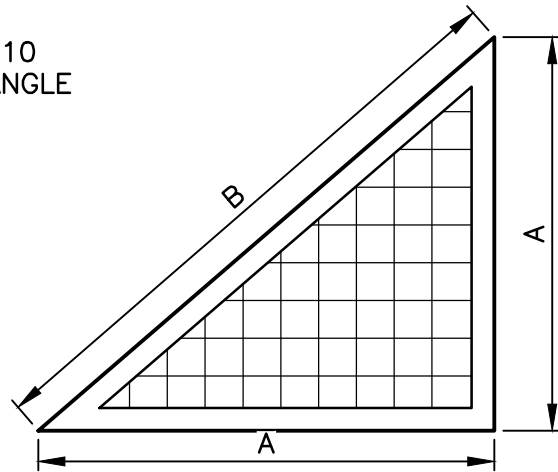

WELDED HINGE

63.5mm x 63.5mm

25.4mm $\phi$  SMOOTH TUBING

6.35mm BENT  
FLATSTOCK

CULVERT CHART		
PIPE DIAMETER	DIMENSIONS	
	A	B
375-450	750	1060
600	900	1270
750	1050	1480
900	1200	1700
1050	1350	1910

**NOTE:**

1. ALL DIMENSIONS ARE IN MILLIMETERS
2. ALL JOINTS TO BE FULLY WELDED
3. SIDE SHALL BE CONSTRUCTED OF 12.7mm $\phi$  ROUND BAR AT 150MM SPACING, EACH DIRECTION
4. USE 25.4mm $\phi$  ROUND BARS FOR FRONT SURFACE
5. FRAME CONSTRUCTED OF L50x50x10 STEEL ANGLE
6. GRATES SHALL BE SECURED TO HEADWALL. CONNECTION TO HEADWALL SHALL BE REMOVABLE FOR MAINTENANCE
7. NO GRATES ON CULVERTS GREATER THAN 1050mm $\phi$  UNLESS REQUIRED BY ENGINEER

No.	Description	No.	Description	No.	Description
Date	2021-01-21	Scale	1:40	Drawn	THM
			TOWN OF QUISPAMIS		Drawing
			CULVERT INLET GRATE		<b>33.SD27</b>

DRAWING NAME: Y:\SAINT JOHN\DATA\PROJECTS\2020\2028\19.00 QUISPAMIS MUNICIPAL SPECIFICATIONS\08 SPEC\CIVIL CAD DETAILS\33.SD28 CULVERT OUTLET GRATE.DWG LAYOUT NAME: SK-31 CULVERT OUTLET GRATE PLOT DATE: December 13, 2022 12:48:01 PM CAD OPERATOR: TRAVISM

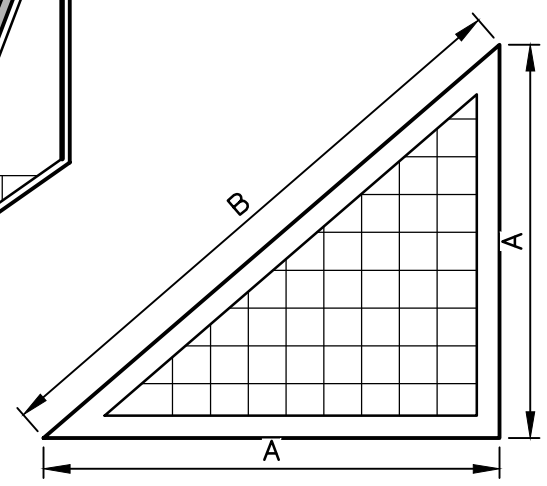
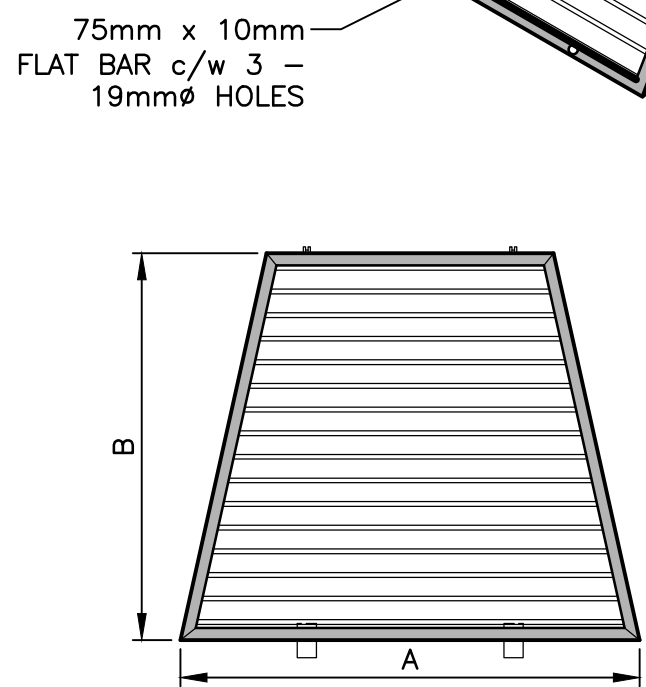
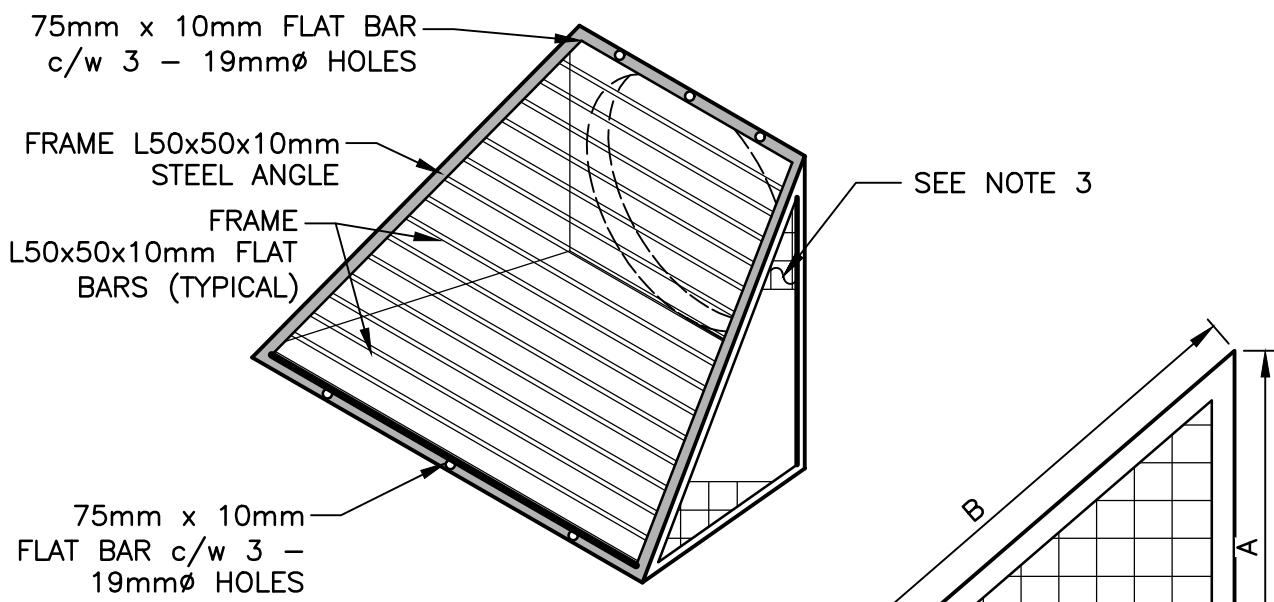

CULVERT CHART		
PIPE DIAMETER	DIMENSIONS	
	A	B
450	750	1060
600	900	1270
750	1050	1480
900	1200	1700
1050	1350	1910

**NOTE:**

1. ALL DIMENSIONS ARE IN MILLIMETERS
2. ALL JOINTS TO BE FULLY WELDED
3. SIDE SHALL BE CONSTRUCTED OF 12.7mmØ ROUND BAR AT 150mm SPACING, EACH DIRECTION
4. FRAME CONSTRUCTED OF L50x50x10 STEEL ANGLE
5. GRATES SHALL BE SECURED TO HEADWALL. CONNECTION TO HEADWALL SHALL BE REMOVABLE FOR MAINTENANCE CONNECTION SHALL BE BASED ON FIELD CONDITIONS
6. NO GRATES ON CULVERTS GREATER THAN 1050mmØ UNLESS REQUIRED BY ENGINEER
7. GRATE BE PAINTED WITH RED OXIDE PRIMER
8. THIS DRAWING IS INTENDED TO SHOW GENERAL SIZE AND CONFIGURATION. FINAL DESIGN OF GRATE SHALL CORRESPOND WITH HEADWALL CONSTRUCTION

No.	Description	No.	Description	No.	Description
Date	2021-01-21	Scale	1:40	Drawn	THM
		TOWN OF QUISPAMIS		Drawing	
		CULVERT OUTLET GRATE		33.SD28	

DRAWING NAME: Y:\SAINT JOHN\DATA\PROJECTS\2020\2028\19.00 QUISPAMIS MUNICIPAL SPECIFICATIONS\08 SPECS\CIVIL CAD DETAILS\33.SD29 PIPE INSULATION COVER LESS THAN 1.8M.PLOT DATE: December 13, 2022 3:14:42 PM CAD OPERATOR: TRAVISM

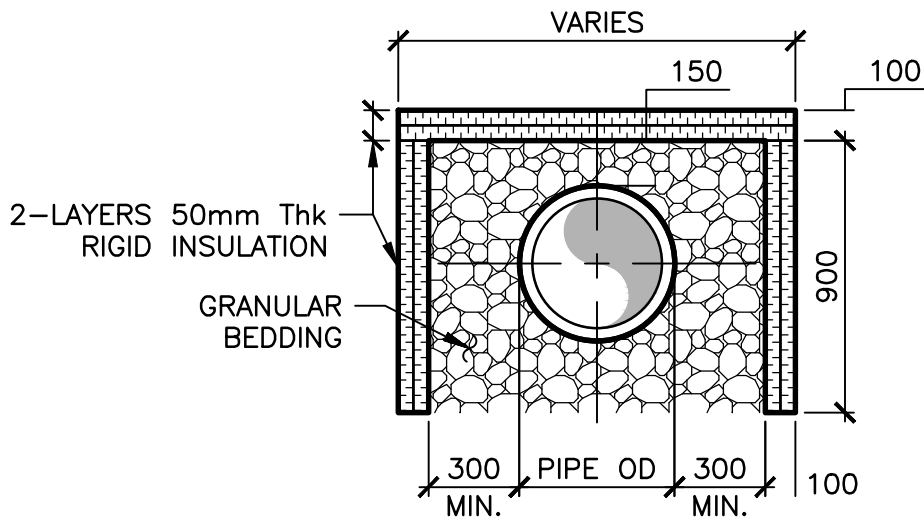

No.	Description	No.	Description	No.	Description
Date	2021-01-21	Scale	1:25	Drawn	THM
			<p>TOWN OF QUISPAMIS</p> <p>PIPE INSULATION (WHERE COVER IS LESS THAN 1.8m)</p>		<p>Drawing</p> <p><b>33.SD29</b></p>

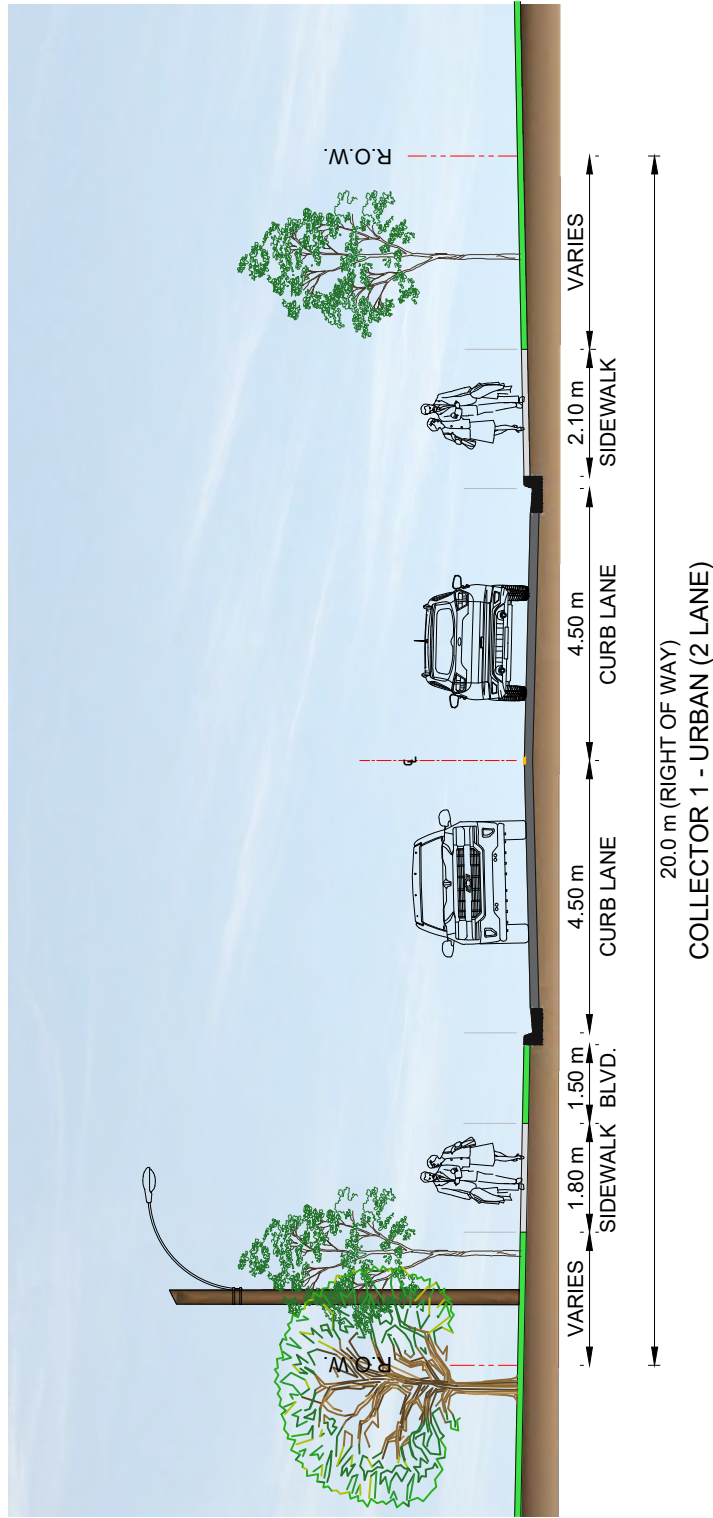

**NOTE:**

1. Sidewalk and boulevard can be replaced with a monolithic sidewalk (minimum width 2.1 m) in constrained areas.
2. Power poles and high mast light standards to be located behind sidewalk where possible.
3. Other municipal infrastructure to be located as per Town's Municipal Specifications.

01	Updated April 2024				
No.	Description	No.	Description	No.	Description

Date	Scale	Drawn
2024-04-01	N.T.S.	JFL

	<p><b>TOWN OF QUISPAMISIS</b></p> <hr/> <p><b>COLLECTOR 1 - URBAN (2 LANE)</b></p>	<p>Drawing</p> <hr/> <p><b>34.SD01</b></p>
--	--	--



**NOTE:**

1. Boulevard is required between travel lanes and M.U.P.
2. Sidewalk and boulevard can be replaced with a monolithic sidewalk in constrained areas, as shown in Drawing 34.SD02.
3. Power poles and high mast light standards to be located behind sidewalk where possible.
4. Other municipal infrastructure to be located as per Town's Municipal Specifications.

01	Updated April 2024				
No.	Description	No.	Description	No.	Description

Date	2024-04-01	Scale	N.T.S.	Drawn	JFL
------	------------	-------	--------	-------	-----

	TOWN OF QUISPAMISIS		Drawing  <b>34.SD02</b>
	COLLECTOR 1 - URBAN (3 LANE) WITH AT TRAIL		

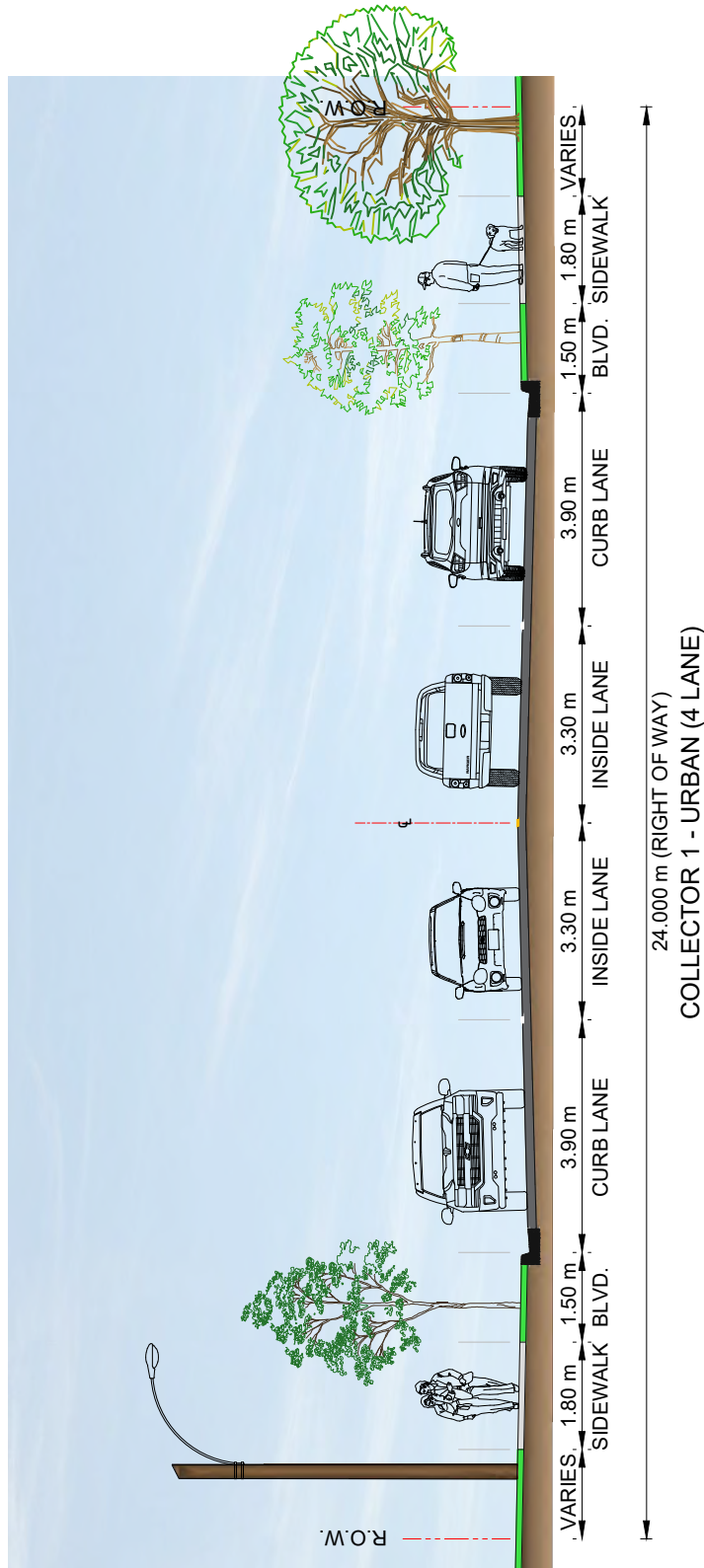

**NOTE:**

1. Power poles and high mast light standards to be located behind sidewalk where possible.
2. Other municipal infrastructure to be located as per Town's Municipal Specifications.

01	Updated April 2024				
No.	Description	No.	Description	No.	Description

Date	2024-04-01	Scale	N.T.S.	Drawn	JFL
------	------------	-------	--------	-------	-----

	TOWN OF QUISPAMISIS	<b>34.SD03</b> Drawing
	COLLECTOR 1 - URBAN (4 LANE)	

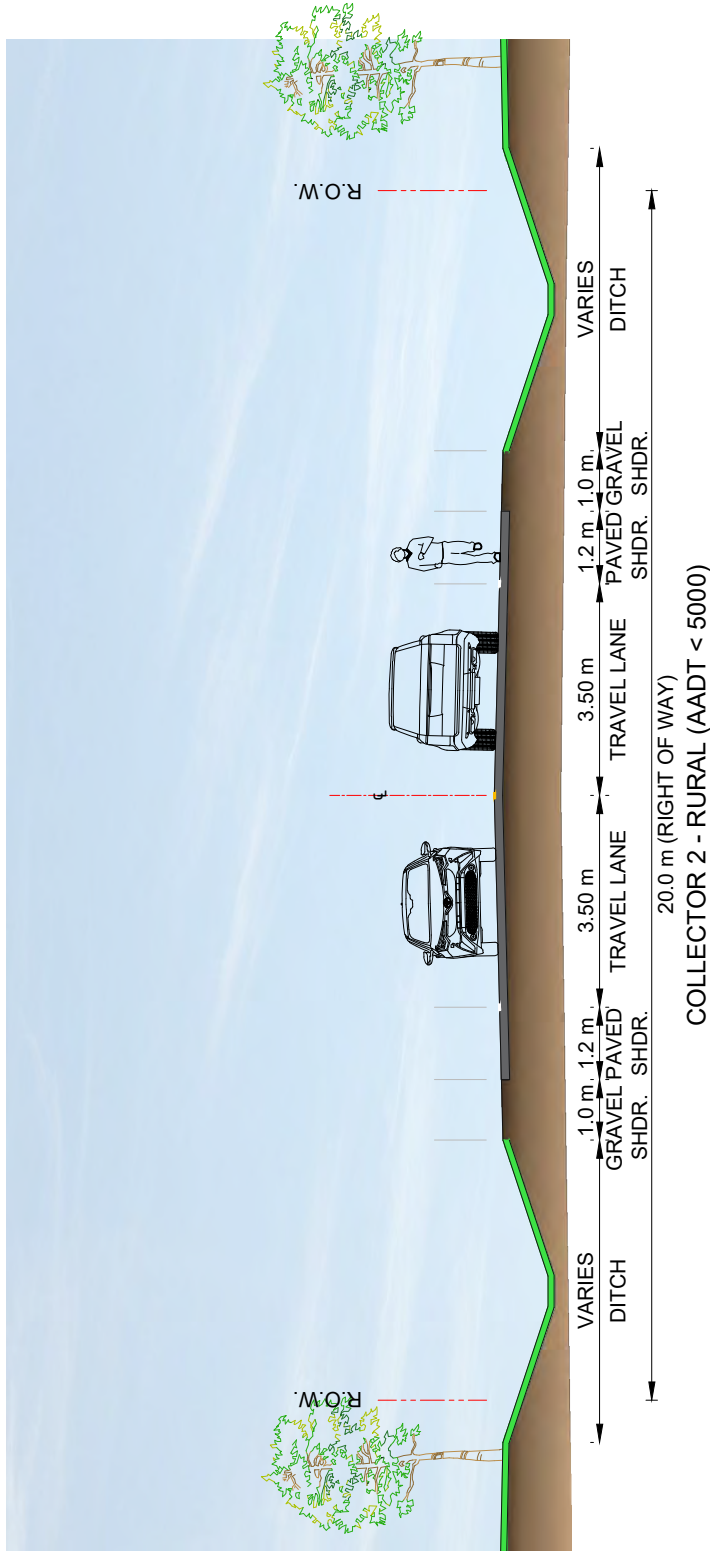

**NOTE:**

1. 1.2 m paved shoulders are considered "walkable".
2. Wider (1.8 m) paved shoulders should be provided if road has an AADT greater than or equal to 5000 AADT.

01	Updated April 2024		
No.	Description	No.	Description

Date	Scale	Drawn
2024-04-01	N.T.S.	JFL

	<p>TOWN OF QUISPAMISIS</p> <hr/> <p>COLLECTOR 2 - RURAL (AADT &lt; 5000)</p>	<p>Drawing</p> <hr/> <p><b>34.SD04</b></p>
---	--	--

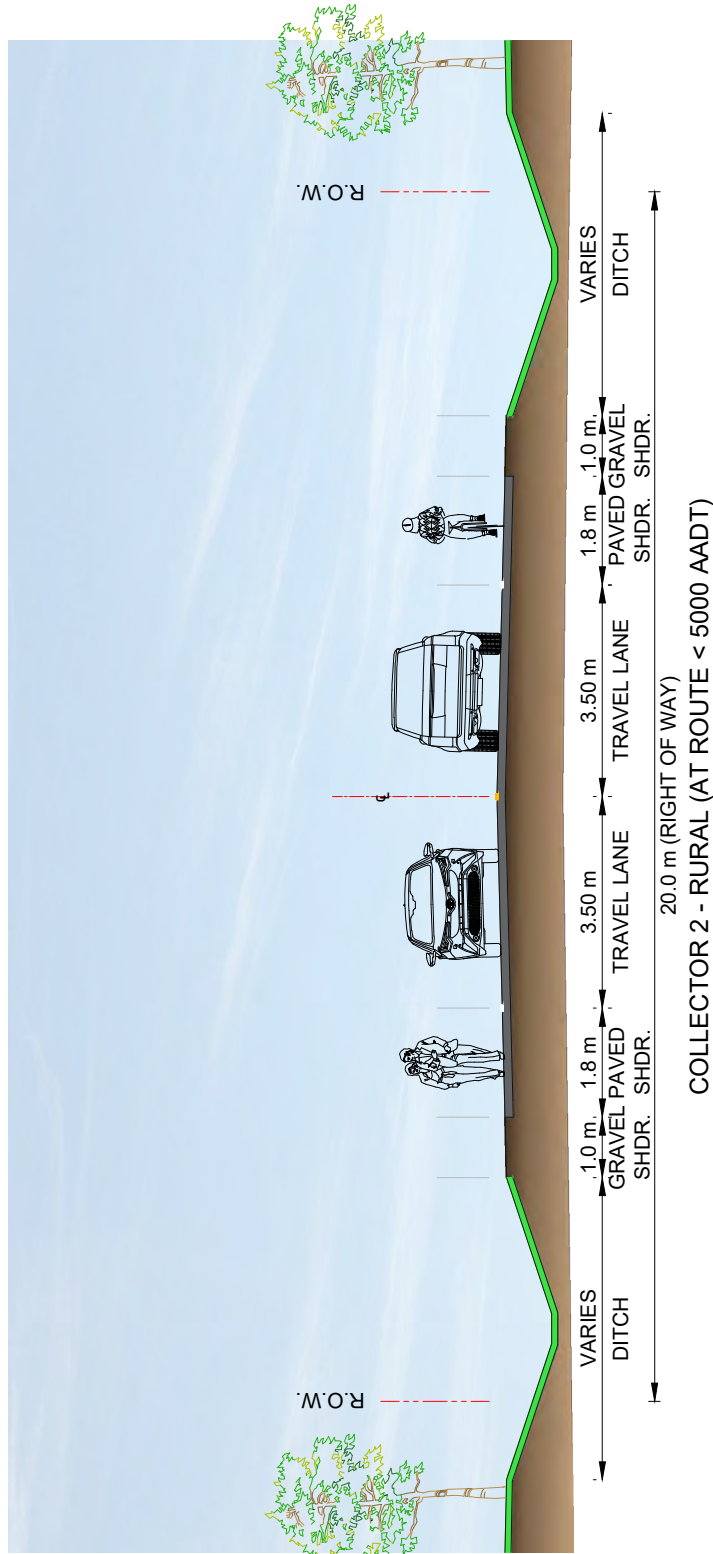

**NOTE:**

1. 1.8 m paved shoulders are considered "walkable" and "bicycle-accessible".
2. Wider (2.5 m) paved shoulders should be provided if road has an AADT greater than or equal to 5000 AADT and is designated as an AT route.

01	Updated April 2024		
No.	Description	No.	Description

Date	Scale	Drawn
2024-04-01	N.T.S.	JFL

	TOWN OF QUISPAMISIS	Drawing
	COLLECTOR 2 - RURAL (AT ROUTE < 5000 AADT)	34.SD05

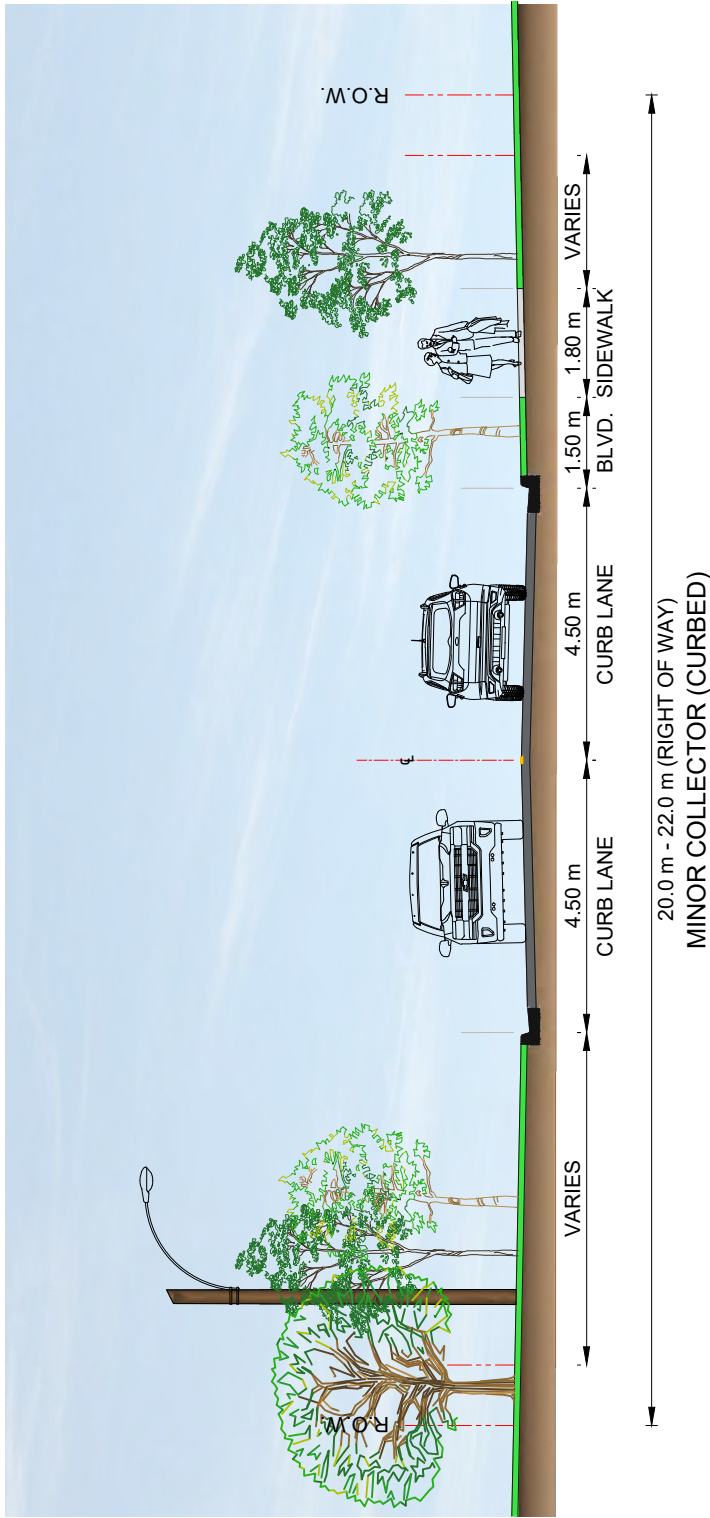

**NOTE:**

1. Sidewalk and boulevard can be replaced with a monolithic sidewalk (minimum width 2.1 m) in constrained areas.
2. Power poles and high mast light standards to be located behind sidewalk where possible.
3. Other municipal infrastructure to be located as per Town's Municipal Specifications.
4. Storm sewer system required between sidewalk and R.O.W. in cut sections.

01	Updated April 2024		
No.	Description	No.	Description

Date	Scale	Drawn
------	-------	-------

2024-04-01

N.T.S.

JFL



TOWN OF QUISPAMISIS

MINOR COLLECTOR  
(CURBED)

Drawing

**34.SD06**

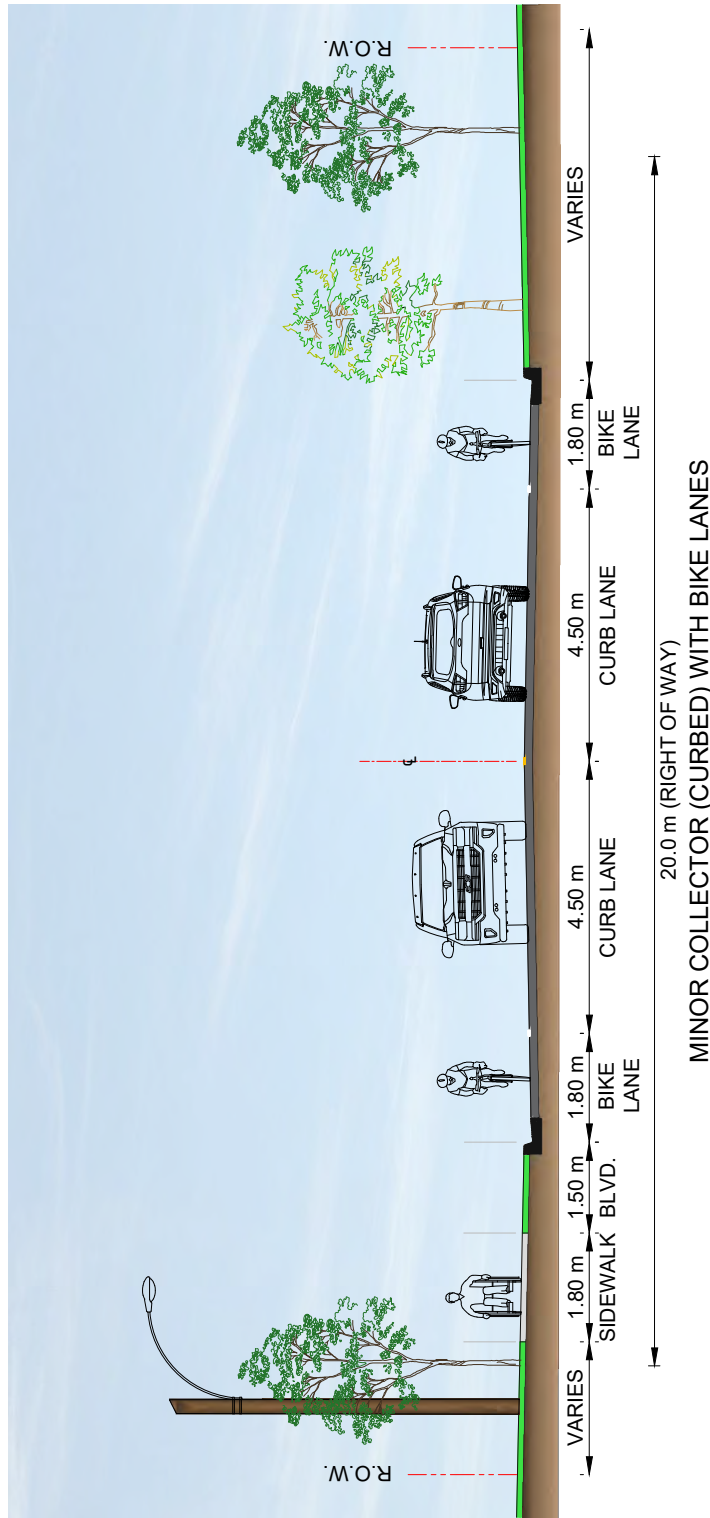

**NOTE:**

1. Sidewalk and boulevard can be replaced with a monolithic sidewalk (minimum width 2.1 m) in constrained areas.
2. Bike lanes are delineated by a solid white longitudinal line along the side of the curb lane.
3. Bicycle pavement markings should be used to identify paved shoulder as bike lane.
4. Power poles and high mast light standards to be located behind sidewalk where possible.
5. Other municipal infrastructure to be located as per Town's Municipal Specifications.

01	Updated April 2024		
No.	Description	No.	Description

Date	Scale	Drawn
2024-04-01	N.T.S.	JFL

	<p><b>TOWN OF QUISPAMISIS</b></p> <p><b>MINOR COLLECTOR (CURBED) WITH BIKE LANES</b></p>	<p>Drawing</p> <p style="font-size: 2em; font-weight: bold;">34.SD07</p>
--	--	--

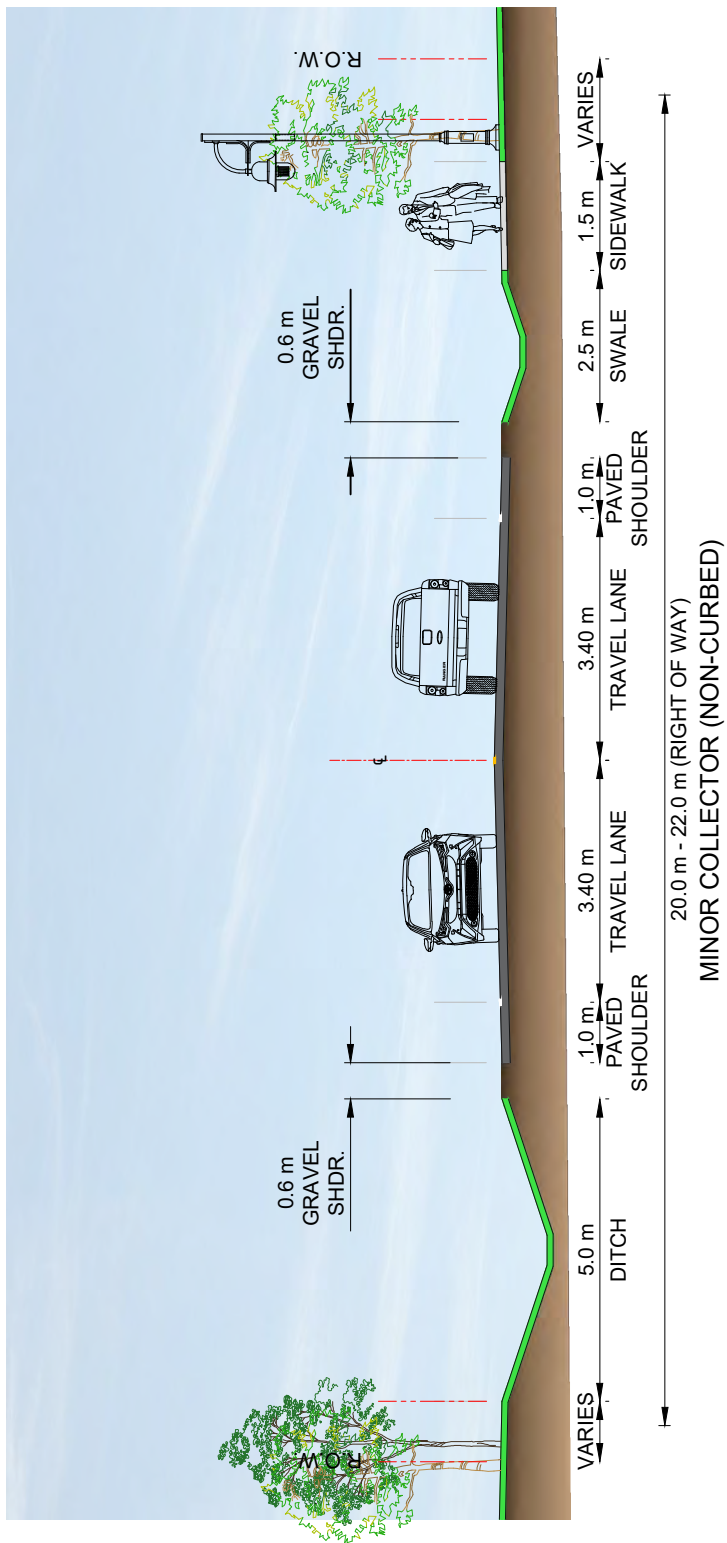

**NOTE:**

1. Power poles and high mast light standards to be located behind sidewalk where possible.
2. Other municipal infrastructure to be located as per Town's Municipal Specifications.

01	Updated April 2024				
No.	Description	No.	Description	No.	Description

Date	2024-04-01	Scale	N.T.S	Drawn	JFL
------	------------	-------	-------	-------	-----

	TOWN OF QUISPAMISIS		Drawing
	MINOR COLLECTOR (NON-CURBED)		

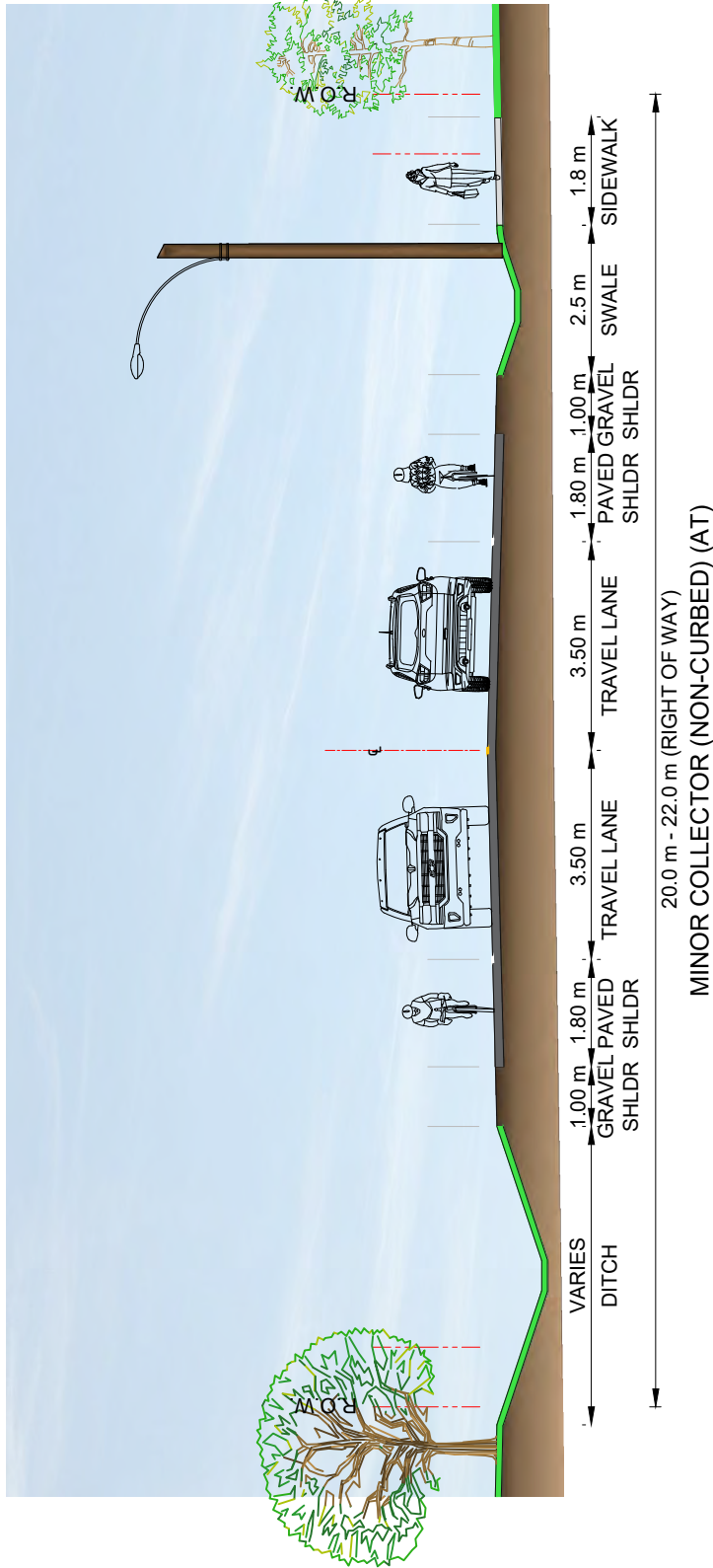

**NOTE:**

1. Bike lanes are delineated by a solid white longitudinal line along the side of the curb lane.
2. Bicycle pavement markings should be used to identify paved shoulder as bike lane.
3. Swale requires installation of storm sewer system for drainage.
4. Power poles and high mast light standards to be located behind sidewalk where possible.
5. Other municipal infrastructure to be located as per Town's Municipal Specifications.

01	Updated April 2024		
No.	Description	No.	Description

Date	Scale	Drawn
2024-04-01	N.T.S.	JFL

	<p><b>TOWN OF QUISPAMISIS</b></p> <hr/> <p><b>MINOR COLLECTOR (NON-CURBED) (AT)</b></p>	<p>Drawing</p> <hr/> <p><b>34.SD09</b></p>
---	---	--

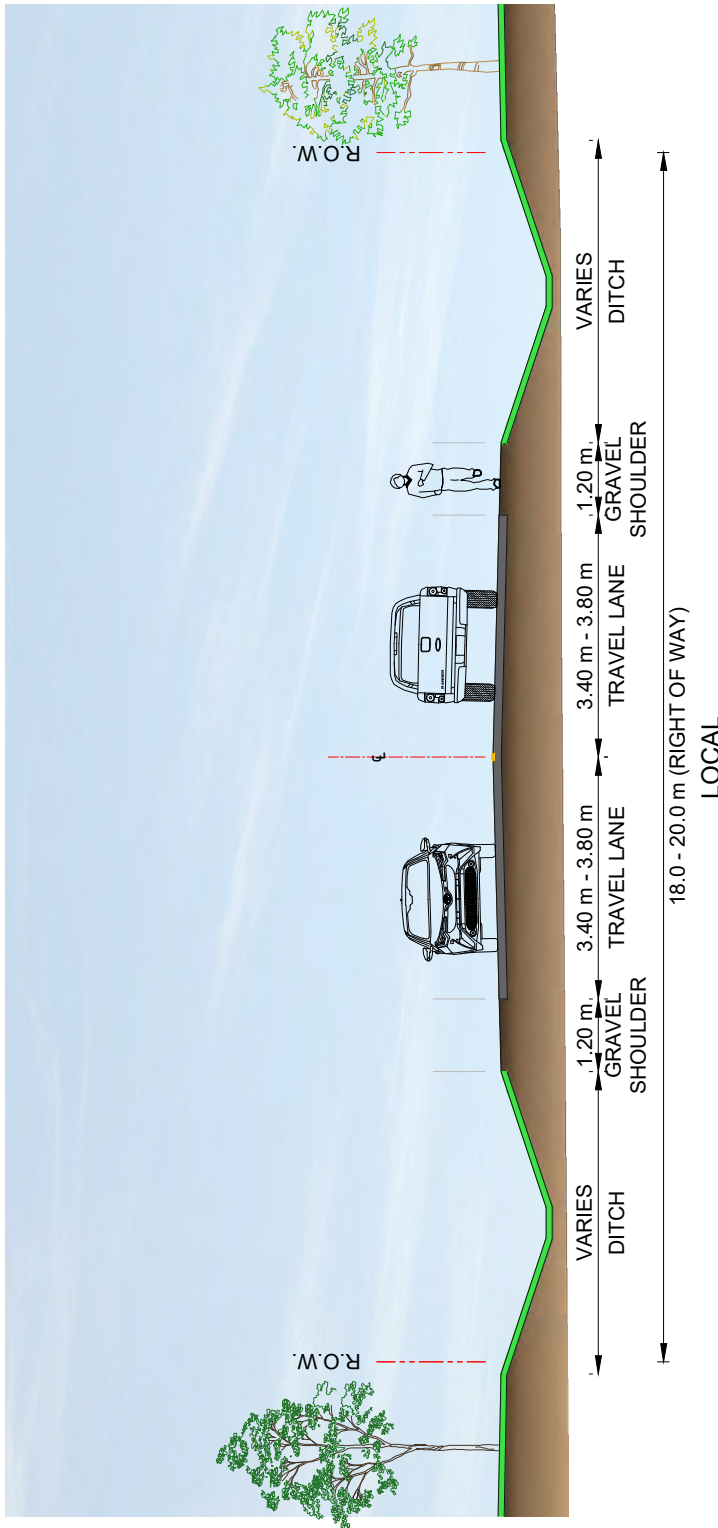

**NOTE:**

1. Wider (4.0 m) travel lanes are recommended where on-street parking is permitted.
2. Travel lanes can be reduced to 3.0m wide in constrained areas.

01	Updated April 2024				
No.	Description	No.	Description	No.	Description
Date	2024-04-01	Scale	N.T.S.	Drawn	JFL
			TOWN OF QUISPAMISIS		Drawing
			LOCAL		<b>34.SD10</b>

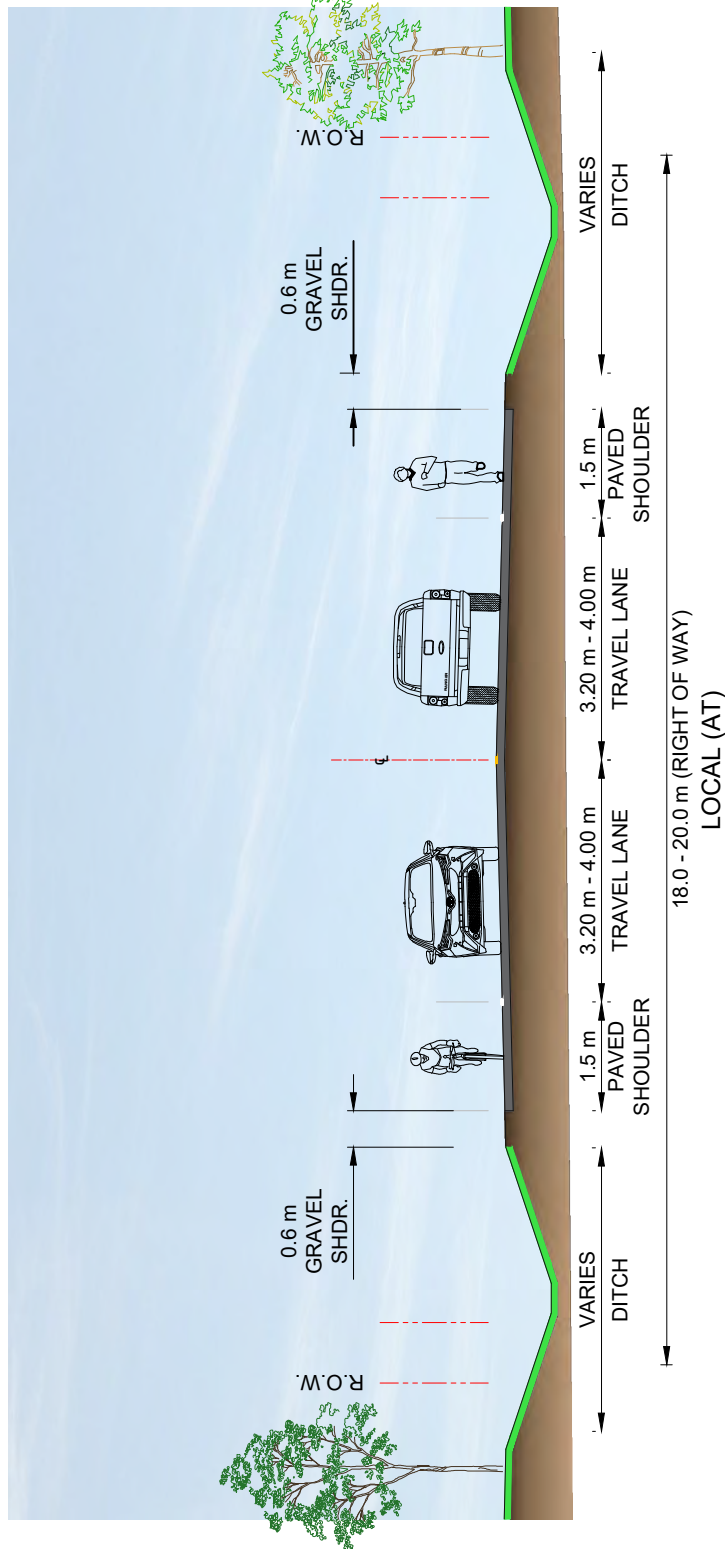

**NOTE:**

1. Paved shoulders are delineated by a solid white longitudinal line along the side of the travel lane.
2. Bicycle pavement markings should be used to identify paved shoulder as bicycle route.

01	Updated April 2024				
No.	Description	No.	Description	No.	Description

Date	2024-04-01	Scale	N.T.S.	Drawn	JFL
------	------------	-------	--------	-------	-----

	TOWN OF QUISPAMISIS	Drawing
	LOCAL (AT)	

DRAWING NAME: I:\8 ENG PUBLIC WORKS 2200-2399\ENGINEERING AND PUBLIC WORKS GENERAL 2200\TOO SPECIFICATIONS AND GUIDELINES\DRAWINGS\34.SD12 GUIDE RAIL TERMINATION.DWG LAYOUT NAME: SK-41 GUIDE RAIL TERMINATION PLOT DATE: April 2, 2024 2:18:50 PM CAD OPERATOR: JLEBLANC

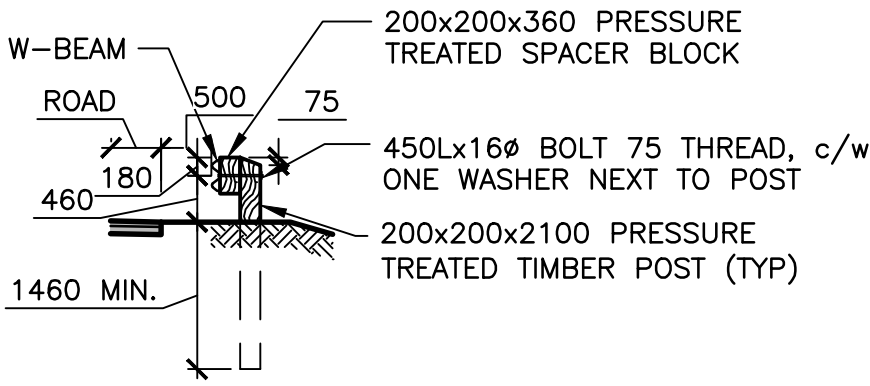

**SIDE VIEW**

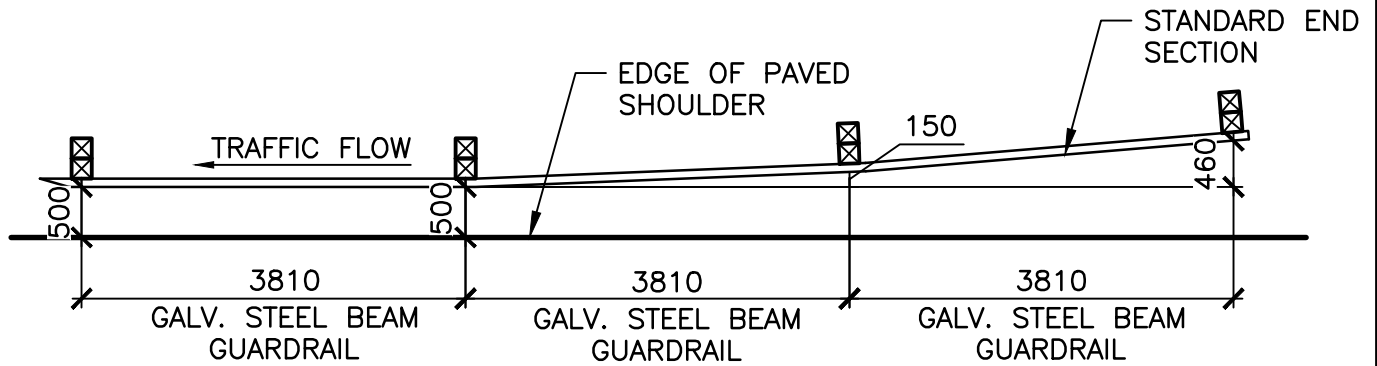

**PLAN**

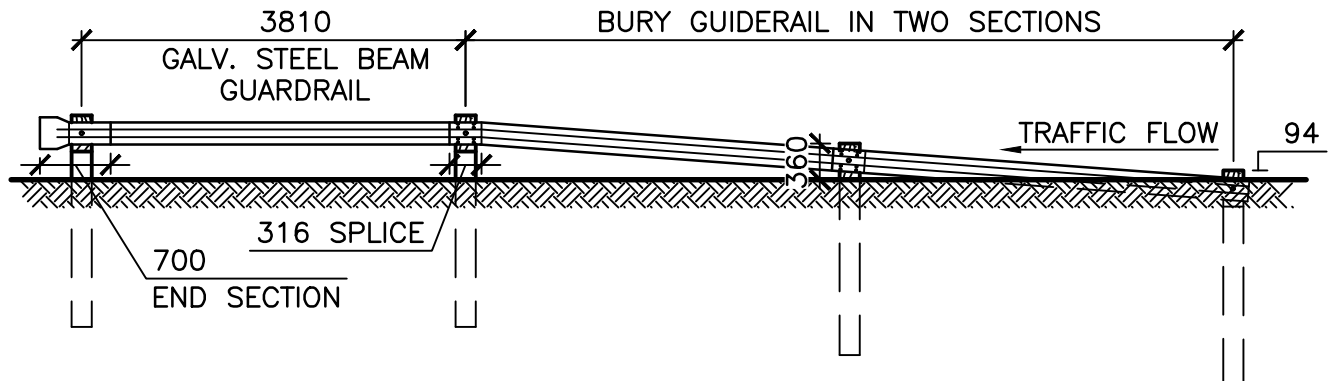

**FRONT ELEVATION**

No.	Description	No.	Description	No.	Description
Date	2024-04-01	Scale	1:75	Drawn	THM



TOWN OF QUISPAMISIS

GUIDE RAIL TERMINATION

Drawing

**34.SD12**

DRAWING NAME: I:\8 ENG PUBLIC WORKS 2200-2399\ENGINEERING AND PUBLIC WORKS GENERAL 2200\TOO SPECIFICATIONS AND GUIDELINES\DRAWINGS\34.SD13 GUIDE RAIL.DWG LAYOUT NAME: SK-40 GUIDE RAIL PLOT DATE: April 2, 2024 2:19:45 PM CAD OPERATOR: JLEBLANC

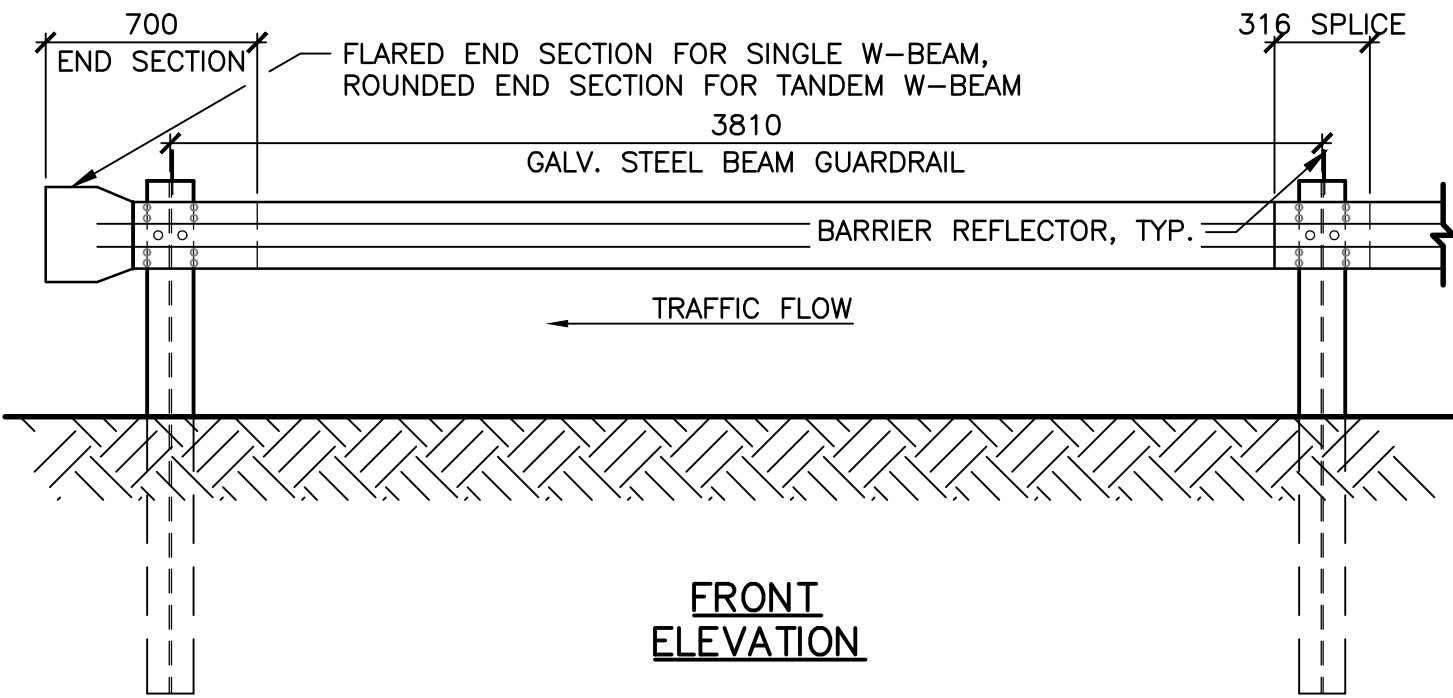
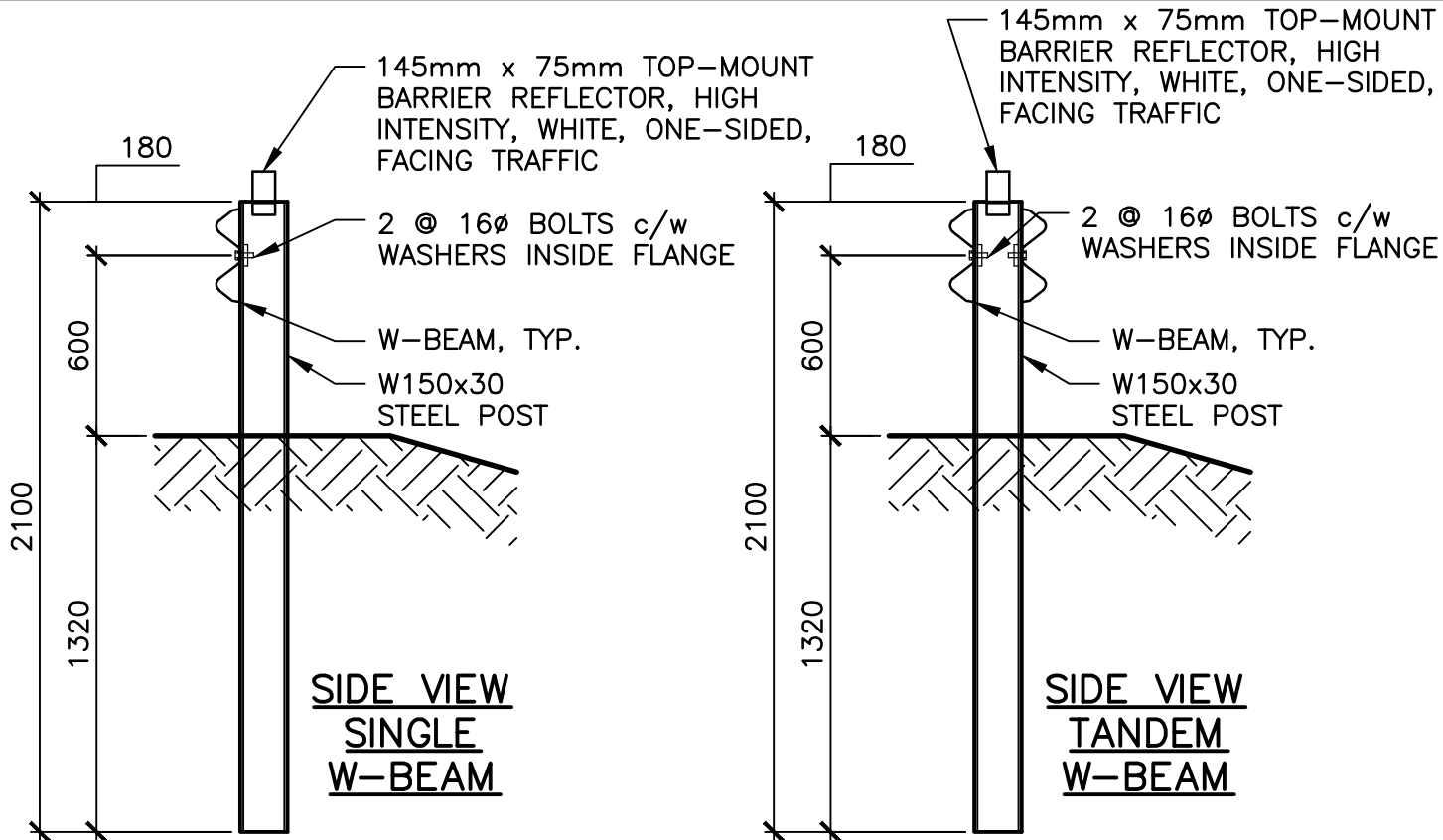

**FRONT ELEVATION**

No.	Description	No.	Description	No.	Description
Date	2024-04-01	Scale	1:25	Drawn	THM
			TOWN OF QUISPAMISIS		Drawing
			GUIDE RAIL		<b>34.SD13</b>